

FARM-FLEET

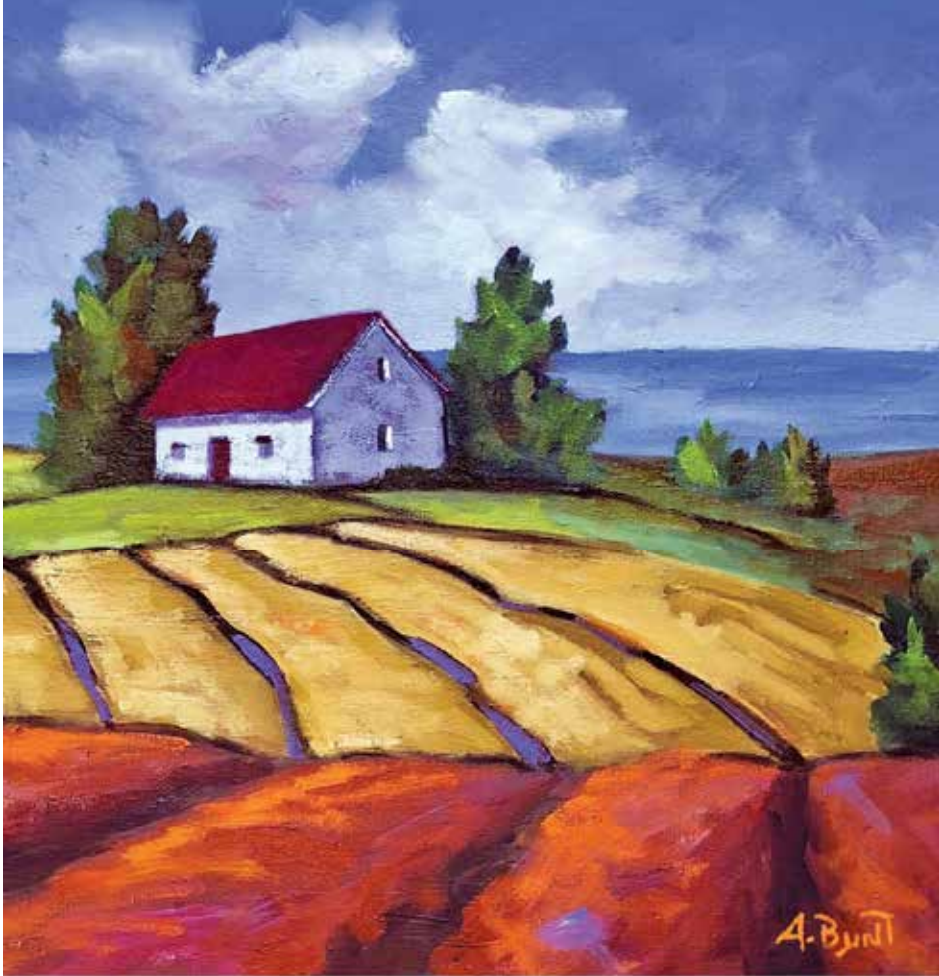

2019 CATALOGUE

COMMERCIAL
CONSTRUCTION
AGRICULTURE

LANDSCAPING
ROCK EQUIPMENT
FORESTRY

CATALOGUE COVER PAINTING BY "AUDREY BUNT"

Cover & back image (cropped) "Ploughed Fields #24" by Audrey Bunt.

AUDREY BUNT BIOGRAPHY

Award winning artist Audrey Bunt was born in Cork, Ireland, later moving to Canada. She lived in Thunder Bay and Coldwater Ontario, until settling on Prince Edward Island. The seascapes and red soil fields of PEI sparked her creative passion to capture its beauty in oil paint and her popularity has required her full-time attention since 2012.

Bunt is inspired by the impressionists with her fascination in the way light can effect colour. This is evident in the many diverse works by her on display. One cannot drive through Montague, PEI without seeing one of the four custom painted welcome signs featuring a historical fact of the town and you might see one of the many commissioned murals painted by Audrey Bunt on a building in Montague. Venturing out on PEI you will find her paintings at several galleries across the island or maybe spot a commissioned painting on the book cover by Audrey Bunt.

Her favorite subjects involve the landscape of PEI which has spawned the hugely successful "Ploughed Fields" series in which she explores the vibrant colours and familiar patterns of the agricultural landscape of this Maritime Province. These bold and colourful paintings have become a signature of her work. To discover more and to see current work go to:

Website: www.audreybunt.com

instagram: [audrey_bunt_art](https://www.instagram.com/audrey_bunt_art)

E-mail: audbunart@yahoo.ca

INDEX

Aerators	38,41,68-69	De-Thatcher.	63, 68
ATV Box Scrapers	99	Discs (also see ATV Discs)	97-98,148-151
ATV Carts	60-61	Disc Harrows	147-149
ATV Discs	97-98	Engine Drive Mowers . . .	19-20
ATV Land Plane	98	Engine Driven Cutters . . .	6-7
ATV Landscape Rake . . .	99	Engine Driven Tillers . . .	31
ATV Scraper Blades . . .	99	Estate Rake.	118
ATV Seeder	77	Estate Sprayers.	92
ATV/UTV Sprayer . . .	90-91,93	Fertilizer Spreaders.	71-79, 82-89
ATV Spreader	77	Finishing Mowers . . .	19-26
Auger Systems	138-139	Flail Mowers	27-30
Bale Forks, Spears & Huggers . .	125-131	Flex Mowers	25-26
Box Scrapers.	52-57	Foam Markers	96
Brooms	158-159	Furrower	134
Canopies	152-153	Grader Blade.	46
Carts	60-61	Grapples . .	107-110, 113-114
Cement Mixers	80-81	Harrows.	100
Chain Harrows.	100	Hay Handling.	125-131
Core Aerators	41,68-69		
Concrete breaker.	142		

INDEX

- Hay Rakes 118-123
Hydraulic Auger Systems . .
 138-139
Hydraulic Top Link 154
Land Plane 47
Landscape Rakes . 15,58-59
Lawn Rollers 70
Lawn Sweepers 64-67
Lawn Vac 67
Loader Adaptor Brackets 156
Logging Winches . . . 104-105
Merger 124
Manure Forks 115
Mixers (Cement) 80-81
Moldboard Plow 132
Offset Discs 150-151
Overseeder 38-39
Packers 146
Pallet Forks 116-117
Poly 3pt. Spreaders . . . 85-86
Post Drivers
 140-141,144-145
Post Hole Diggers . . 136-139
Post Puller 101
Potato Planter/Hiller . . . 133
Powered Landscape Rake .
 58-59
Pulverizers 40
Quick Attach Brackets
 155-156
Quick Hitches 3 Pt. 154
Rakes (Hay) 118-124
Rakes (Landscape) 15, 58-59
Rakes (Rock) 110-113
Rippers 134-135
Rock Buckets 110-113
Rock Rakes 110-113
Rollers 70
Rotary Broom 158-159
Rotary Cutters 6-14
Rotary Tillers 31-37
Scraper Blades 42-49
Seeders 38-39
Sickle Bar Mowers . . . 16-17
Skid Steer - Adaptor . . . 156
Skid Steer-Cement Mixer 80
Skid Steer-Grader Blade . 46
Skid Steer-Power Rake
 58-59
Skid Steer - Rotary Brooms
 158-159
SmartLink system 68
Snow Plow & Blades . . 48-51
Spiker/Aerator . . 38,41,68-69
Spray Foam Markers 96
Sprayers 90-96
Spreaders 71-79,82-89
Stone Forks 110-113
String Trimmer 18
Stump Grinder 106
Sub-Soilers 134-135
Sweepers 64-67
Tillers 31-37
Top Links 154
Tractor Canopies . . . 152-153
Trailers 62,143
Tree Cutter 14
Tree Saw 102-103
Tree Puller 101
Vacuums 67
Winches 104-105
Windrow Merger 124



- Aerators 68-69,79
Carts 60-61
Core Aerators 68-69,79
De-Thatcher 63,68
Fertilizer Spreaders . . . 71-75
Lawn Rollers 70
Lawn Sweepers 64-66
Lawn Vac 67
Rollers 70
Smart Link Attachments . . 68
Spreaders 71-75
Sweepers 64-66
Tillers, Engine Driven 31
Tractor Carts 60-61
Vacuums 67

TABLE OF CONTENTS



www.amazone.de

Spreaders 87-89

BARE-Co

www.bare-co.com

Tractor Canopies 152-153



www.befco.com

Aerator/Overseeder Green Rite . 38

Baby Hop Ground Driven 83

Core Aerators 41

Finishing Mowers

Engine Driven Finish Mower . . 20

C30 Series 22

C50 Series 23

C70 Series 24

Flex Mowers 25-26

Flail Mowers

H40 Series, Hurricane 27

H70 Series, Hurricane 28

H80 Series, Hurricane 29

Flail Shredder 30

Hay rakes 119

Overseeders 38-39

Rotary Tillers

T30 Series 33

T40 Series 34

T50 Series 35

T60 Series 36

T70 Series 37

Sickle Bar Mower 17

Soil Pulverizers 40

Spreaders 83-84,86

Turbo Hop Spreader 86



www.brownmanufacturing.com

Rotary Cutters HD 12-13

Rotary Cutters Tree Cutter 14

Tree Saw 102-103



Hammer Concrete Breaker . . . 142

Hydraulic Auger System . . . 138-139

Mega Mixer 81

Post Driver 140-141

Tree & Post Puller 101



Sickle Bar Mower 16

ESTATE RAKE™

Estate Rake 118



www.fimcoindustries.com

Carts 60-61

Lawn Rollers 70

Sprayers 90-95

ATV Spreader 77

Spreaders - Broadcast . . . 77 & 78



www.fransgard.dk

Accessories - Winch 105

Logging Winches 104

Hay Rakes Combi 122-123

Hackett Harrows

Chain Harrows 100



www.shoule.com

Rock Buckets 112-113



Hay Rakes Action 120-121

Windrow Merger 124

TABLE OF CONTENTS



www.mdsmsg.com

Rock Buckets 110-111



www.multiva.info

Trailers 62,143



ROTOMECC

Rotary Tillers 32



Quick Hitches 154



Finishing Mower Eng.Driven . . . 19

Rotary Cutter Eng. Driven 6-7

Spreader ATV,UTV or Truck 76

String Trimmer 18



Furrower 134

Scraper Blades 45

Spreaders 82



Box Scrapers 52

Landscape Rake 15

Plow 3 Pt. 1 or 2 Furrow 132

Rotary Cutters 8-11

Scraper Blades 42-43



Spray Foam Markers 96



www.monroetufline.com

ATV

Box Scrapers 99

Discs Harrows 97 & 98

Land Plane 98

Landscape Rake 99

Scraper Blade 99

3 Pt. Box Scraper H.D. 53-57

Pull Type Box Scraper 57

Land Plane 47,98

"Offset Discs ""42 Series"" 150-151

Packers 3 Pt. 146

Scraper Blades 44

Sub-Soilers 135

THE Series Disc Harrows 147

TW6 Series Disc Harrows . 148-149



www.worksaver.com

Adaptor brackets 155 - 156

Bale Forks & Spears 125-131

Cement Mixers 80

Grader Blade - Skid Steer 46

Grapples 107-109, 114

Hay Handling Attachments 125-131

Hydraulic Top Link 154

Landscape Rakes 15,58-59

Manure Forks 115

Pallet Forks 116-117

Post Drivers 3Pt. & Skid Steer

. 144-145

Powered Landscape Rake . . . 58-59

Post Hole Diggers 136-137

Rotary Broom 158-159

Snow Blades 48-49

Snow Pusher 50-51

Stump Grinder 106

ROTARY CUTTER

Engine Driven

Walk Behind



[Click for Video](#)

Swisher's 24" walk-behind rough-cut mower is perfect for cutting trails through the woods and clearing fields and ditches year-round. It will clear the densest undergrowth and saplings up to 1-1/2 inches in diameter. This self-propelled walk-behind features an 11-1/2-HP Briggs & Stratton engine and a heavy-duty fabricated cutting deck with a 4" fixed cutting height. The single, fixed hardened-steel blade zips through brush and saplings with ease, and the blade is enclosed for maximum safety. Handlebar mounted controls are easily accessed for total control and safety. The adjustable height handlebar eases operator control. Two heavy duty front casters remove the unit weight off the operator and improve stability and ease of use. Large pneumatic chevron tires roll easily over the roughest terrain for excellent traction in all conditions. The four-speed transmission is great for setting a comfortable pace, and a reverse mode is handy for backing out of rough spots. Front and side safety deflectors protect against flying debris while the wire shield protects electrical components.

- * 11.5 HP Briggs and Stratton recoil start engine
- * 24" self-propelled walk-behind rough cut mower
- * Single fixed hardened steel, rough cut blade
- * 4" fixed cutting height
- * 4-Speed transmission with reverse
- * Front safety deflectors and wire shield
- * Operator presence blade engagement and drive control
- * Adjustable height handlebar with hand controls
- * Large pneumatic chevron tread tires
- * 2 Heavy duty front casters

MODEL	DESCRIPTION	WEIGHT	LIST PRICE
WBRC11524C	11.5 HP, 24" walk behind Rotary Cutter	383 lbs.	\$3449

ROTARY CUTTER

Engine Driven

Pull Type



SWISHER rough cut Trailcutter is perfect for any big mowing job. Backed by the power of 60 + years of design experience, this mower is designed to dramatically reduce mowing time. The SWISHER Trailcutter easily attaches to your ATV, UTV or lawn tractor. This model will cut saplings up to 3" in diameter and thick brush with two heavy duty swinging blades. A convenient single point cutting height adjustment has a 3" to 7" range. The remote control operator console lets you safely engage and disengage the mower blades from your ATV or tractor seat.

- * 14.5HP Kawasaki v-twin electric start engine
- * Offsets, left/right/center articulating
- * Two 16" pneumatic tires
- * Two H.D. hardened steel swinging blades
- * Up to 3" sapling cutting diameter
- * 2.5 US gallon fuel capacity
- * 2" trailer hitch ball coupler
- * 12V electric start
- * Remote Operator Control Console
- * 12V battery EXTRA (not included)

MODEL	DESCRIPTION	WEIGHT	LIST PRICE
RC14544CPKA	44", 14.5 HP Kawasaki Commercial Pro Engine Electric start, 2 wheel	400 lbs.	\$4999

ROTARY CUTTERS

3 Pt. PTO

1200 Series

Standard Duty



These affordable rotary cutters, built by TITAN Implements, are ideal for the cutting of grass, weeds and light brush up to 1.5" diameter. They are designed to work with 15 to 65 HP tractors, and are available in 48", 60", and 72" widths. This unit features an 11 ga. deck, 7" side bands, CAT I – 3 Pt Hitch, and 540 RPM shear pin PTO. Manufactured in USA.

- * Cat I, 3 Pt hitch
- * Series 4 Shear pin PTO shaft with PTO shielding
- * Pan stump jumper
- * Single 4" x 15" wheel with solid laminated rubber tire
- * Regreaseable cast wheel hub
- * 55 HP rated gear box
- * 11 ga. Steel round back deck with 7" sides
- * 1.5" cutting capacity
- * Optional safety guard chains available

MODEL	MAXIMUM PTO HP	CUTTING WIDTH	WEIGHT	LIST PRICE
1204	45 HP	48" / 4'	538 lbs.	\$1679
1205	45 HP	60" / 5'	596 lbs.	\$1739
1206	65 HP	72" / 6'	726 lbs.	\$2199

The manufacturer highly recommends the use of optional safety guard chains.

OPTIONS:

MODEL	DESCRIPTION	LIST PRICE
CG1204	48" / 4' Safety guard chain kit	\$499
CG1205	60" / 5' Safety guard chain kit	\$599
CG1206	72" / 6' Safety guard chain kit	\$639

ROTARY CUTTERS

3 Pt. PTO

1400 Series

Medium Duty



Unit shown with optional safety chains

These affordable rotary cutters built by TITAN Implement are ideal for the cutting of grass, weeds and light brush up to 2" diameter. These units feature a 11 ga. deck, CAT. I - 3 Pt. Hitch, and 540 RPM PTO with slip clutch. Manufactured in U.S.A.

- * Cat I, 3 Pt hitch
- * Series 4 Slip clutch PTO shaft with PTO shielding
- * 1/4" round formed steel blade carrier (stump jumper)
- * Single 4" x 15" solid laminated rubber tire
- * Regreaseable cast wheel hub
- * 75 HP rated gear box
- * 11 ga. Steel deck with 7" high sides
- * Flat bar and formed channel deck reinforcing
- * 2" cutting capacity
- * Optional safety guard chains available

MODEL	MAXIMUM PTO HP	CUTTING WIDTH	WEIGHT	LIST PRICE
1405SC	90 HP	60" / 5'	689 lbs.	\$2349
1406SC	90 HP	72" / 6'	820 lbs.	\$2749

The manufacturer highly recommends the use of optional safety guard chains.

OPTIONS:

MODEL	DESCRIPTION	LIST PRICE
CG1205	60" / 5' Safety chain guard kit	\$599
CG1206	72" / 6' Safety chain guard kit	\$639

ROTARY CUTTERS

3 Pt. PTO

1500 Series (7')

Medium Duty



This 7' affordable rotary cutter, built by TITAN Implements, is ideal for the cutting of grass, weeds and light brush up to 3" diameter. This unit features a 10 ga. deck, 8" side bands, CAT II – 3 Pt Hitch, and 540 RPM PTO with slip clutch. Manufactured in USA.

- * HP requirements: 55 - 95
- * Cat II, 3 Pt hitch
- * Series 6 Slip clutch PTO shaft with PTO shielding
- * 3/4" plate stump jumper
- * Dual wheels with 4" x 15" solid laminted rubber tire
- * Regreaseable cast wheel hub
- * 150 HP rated gear box
- * 10 ga. Steel round back deck with 8" sides
- * Flat bar and formed channel deck reinforcing
- * 3" cutting capacity
- * Optional safety guard chains available

MODEL	MAXIMUM PTO HP	CUTTING WIDTH	WEIGHT	LIST PRICE
1507	90 HP	84" / 7'	1305 lbs.	\$4189

The manufacturer highly recommends the use of optional safety guard chains.

OPTIONS:

MODEL	DESCRIPTION	LIST PRICE
CG1507	84" / 7' Safety chain guard kit	\$889

ROTARY CUTTERS

3 Pt. PTO

1800 Series (8')

Heavy Duty



Shown with optional Safety Chain Guard

This 8' Heavy-Duty Dual Spindle Cutter is designed for heavy duty applications such as weeds, grass, and brush up to 3" diameter. This cutter is designed to work with 42 minimum HP tractors, with CAT I & II 3 Pt Hitch. The cutter features a 94" cutting width, and cutting height from 2" to 10". Manufactured in USA.

- * HP requirements: 42 min. to 70 max.
- * Cat I & II, 3 Pt hitch
- * Series 5 Slip clutch PTO shaft with PTO shielding
- * 5/8" plate stump jumper
- * Dual wheels with 4" x 15" solid laminted rubber tire
- * Regreaseable cast wheel hub
- * 125 HP rated centre gear box
- * 100 HP rated outboard gear boxes
- * 10 ga. Steel deck with 8" sides
- * 3" cutting capacity
- * Optional safety guard chains available

MODEL	MAXIMUM PTO HP	CUTTING WIDTH	WEIGHT	LIST PRICE
1808	125 HP	94"	1250 lbs.	\$6649

The manufacturer highly recommends the use of optional safety guard chains.

OPTIONS:

MODEL	DESCRIPTION	LIST PRICE
CG1708	94" Safety chain guard kit	\$999

ROTARY CUTTERS 410 SERIES HEAVY DUTY 3 Pt.



415



417

With over 50 years of innovative design and production, BROWN Mfg. has set the standard for heavy duty rotary cutters. The 410 series rotary cutter comes with a 130 HP rated gearbox, with limited 5 year warranty. Available in four sizes, 5', 6', 7' & 8' with a slip-clutch PTO Shaft. This heavy duty cutter is tough enough to cut heavy brush and trees up to 2" in diameter.

- * Deck Design, round back, reinforced
- * Deck Construction, all welded 7 gauge (3/16") steel
- * 130 HP rated gearbox, limited 5 year warranty
- * Cat. 5 Slip-clutch PTO shaft on 5' & 6' models
- * Cat. 6 - 4 Disc slip-clutch PTO shaft on 7' and 8' models
- * Laminated solid rubber tail wheels
- * 5' & 6' single tail wheel
- * 7' & 8' dual tail wheels
- * 5' & 6' Cat. I/II clevis style 3 Pt. hitch
- * 7' Cat. II, 8' Cat. II / III clevis style 3 Pt. Hitch
- * Stump Jumper 3/16" with 1" x 5" solid bar
- * 1/2" x 4" heat treated/up draft type blades
- * Replaceable slides
- * Replaceable front rubber deflector
- * Optional chain guards available

MODEL	DESCRIPTION	WEIGHT	LIST PRICE
415	5' Rotary Cutter, Single Tail Wheel	900 lbs.	\$4499
416	6' Rotary Cutter, Single Tail Wheel	1060 lbs.	\$5299
417	7' Rotary Cutter, Dual Tail Wheel	1375 lbs.	\$7599
418	8' Rotary Cutter, Dual Tail Wheel	2096 lbs.	\$8799

OPTIONS:

MODEL	DESCRIPTION	WEIGHT	LIST PRICE
4-007	5' Front Chain Guard	53 lbs.	\$399
232-0031	5' Rear Chain Guard	21 lbs.	\$339
4-009	6' Front Chain Guard	57 lbs.	\$429
232-0030	6' Rear Chain Guard	37 lbs.	\$369
4-011	7' Front Chain Guard	67 lbs.	\$449
232-0032	7' Rear Chain Guard	42 lbs.	\$449
232-0830	8' Front Chain Guard	84 lbs.	\$549
232-0850	8' Rear Chain Guard	57 lbs.	\$499

ROTARY CUTTERS 600 SERIES HEAVY DUTY 3 Pt.



[Click for Video](#)



Model 684 shown with dual wheels

With over 50 years of innovative design and production, BROWN Mfg. has set the standard for heavy duty rotary cutters. The 600 series rotary cutter comes with a 145 HP rated gearbox, with limited 5 year warranty. Available in two sizes, 6' and 7' with a slip-clutch PTO Shaft, this heavy duty brush cutter is tough enough to cut heavy brush and trees up to 4" in diameter.

- * Deck Construction, all welded 1/4" thick, steel plate
- * 145 HP rated gearbox, 1:1.5 ratio
- * Available in 540 RPM & 1000 RPM
- * Cat. 8 - 4 Slip-clutch PTO shaft
- * Laminated solid rubber tail wheels 5.00 x 8
- * Available with single or dual tail wheel
- * Cat. II clevis style with flex link 3 Pt. hitch
- * 1-1/4"- 6' & 1"- 7' solid blade bar
- * 5/8" x 6" Blades(Ultra-Kor tm)
- * Replaceable slides 5/8" x 2 1/2"
- * Reinforced rear deflector shield
- * Standard front safety chain guards

MODEL	DESCRIPTION	WEIGHT	LIST PRICE
672HD	6' Brush Cutter 540 RPM Single tail wheel	1600 lbs	\$11,599
672HD-1	6' Brush Cutter 1000 RPM Single tail wheel	1600 lbs	\$11,599
672HD-D	6' Brush Cutter 540 RPM Dual tail wheel	1720 lbs	\$12,399
672HD-D-1	6' Brush Cutter 1000 RPM Dual tail wheel	1720 lbs	\$12,399
684	7' Brush Cutter 540 RPM Dual tail wheel	2200 lbs	\$13,299
684-1	7' Brush Cutter 1000 RPM Dual tail wheel	2200 lbs	\$13,299

ROTARY CUTTER TREE CUTTER



[Click for Video](#)



The BROWN Mfg. 3 Pt. hitch Tree Cutter can give you the high performance and ability you expect from a machine of this quality. With either an open deck or the versatility of a folding deck unit you can cut and mulch trees, up to 8" diameter.

Model Price	TCO-2505C \$13,799	TCO-2605C \$15,399	TCO-2625C \$17,199	TCF-2605 \$17,299	TCF-2625 \$19,199
Model/RPM	Open Deck 540 RPM	Open Deck 540 RPM	Open Deck 540 RPM	Folding Deck 540 RPM	Folding Deck 540 RPM
Model Price	TCO-2500C \$13,799	TCO-2600C \$15,399	TCO-2620C \$17,199	TCF-2600 \$17,299	TCF-2620 \$19,199
Model/RPM	Open Deck 1000 RPM	Open Deck 1000 RPM	Open Deck 1000 RPM	Folding Deck 1000 RPM	Folding Deck 1000 RPM
Cutting Width	60"	72"	72"	72"	72"
PTO	Over-running 4 Disc Slip Clutch PTO				
Frame	3 x 3 x 1/4" Tubing	3 x 3 x 1/4" Tubing	3 x 3 x 1/4" Tubing	3 x 3 x 1/4" Tubing	3 x 3 x 1/4" Tubing
Deck	3/16" Plate Reinforced	Reinforced Double 1/4" plate to 1/2" total	Reinforced Double 1/4" plate to 1/2" total	Reinforced Double 1/4" plate to 1/2" total	Reinforced Double 1/4" plate to 1/2" total
Weight	1,705 Lbs.	2,240 Lbs.	2,455 Lbs.	2,565 Lbs.	2,710 Lbs.
Rear Guard / Rear Deck	2 Coil springs, collapsible push bar type	2 Coil springs, collapsible push bar type	2 Coil springs, collapsible push bar type	Twin folding Hydraulic rear sec- tion	Twin folding Hydraulic rear sec- tion
Gear Box	145 HP	145 HP	165 HP	145 HP	165 HP
H.P.	50 to 90	60 to 90	70 to 100	70 to 90	80 to 100
Material Size	6" Maximum	6" Maximum	8" Maximum	6" Maximum	8" Maximum

2620 Series Available with Mechanical Clutch PTO

LANDSCAPE RAKES

3 Pt.



5100 Series Models



LRHD Model
Shown with optional Dual Gauge Wheel Kit

These landscape rakes manufactured by WORKSAVER and TITAN Implement make a great landscape attachment for your tractor. With HP ratings of up to 60 HP and working widths 4' to 8' we can match your requirements with the rake your tractor can handle. Units come with heat treated spring steel teeth spaced 1' apart. Gauge wheels are optional.

- * 1" x 5/16" x 27" tines
- * 5 backfill angle positions 4', 5', 6' & 7'
- * 5 forward angle positions 4', 5', 6' & 7'
- * 7 backfill angle positions LRHD models
- * 7 forward angle positions LRHD models
- * Turns 360°
- * Cat. I - 3 Pt. hitch

TITAN IMPLEMENT

MODEL	WIDTH	HP REQ'D	WEIGHT	LIST PRICE
5104	4' / 48"	45	158 lbs.	\$759
5105	5' / 60"	45	180 lbs.	\$869

WORKSAVER

MODEL	WIDTH	HP REQ'D	WEIGHT	LIST PRICE
MCR6	6' / 72"	40	187 lbs.	\$1119
MCR7	7' / 84"	40	199 lbs.	\$1169
LRHD7	7' / 84"	60	330 lbs.	\$1719
LRHD8	8' / 96"	60	365 lbs.	\$1839

OPTIONS FOR WORKSAVER:

MODEL	DESCRIPTION	WEIGHT	LIST PRICE
SGW10	Single gauge wheel kit	26 lbs.	\$359
DGW20	Dual gauge wheel kit	57 lbs.	\$659

SICKLE BAR MOWERS



[Click for Video](#)



For tractors from 20 to 75 HP, the double action sickle bar mowers are Category I/II 3 Pt. hitch mounted. Units come with a safety breakaway bar that helps protect the cutter from obstructions in the field. Units come with a second sickle cutting knife. All units are equipped with a hydraulic lift on the cutter bar, single acting, tractor must be equipped with rear remote hydraulic couplers.

- * HP Requirements: 20-75, 540 RPM
- * Double action sickle bar
- * Adjustable 3 Pt. hitch
- * Safety release
- * 3 Pt. linkage, Cat. 1 and 2
- * Extra blade and chain with hook
- * Transport blade protection
- * Hydraulic lift system
- * Heavy duty shielded PTO shaft (1-3/8" ASAE Cat. 4)
- * Cuts at 45° up and 45° down
- * Belt Driven
- * Hydraulic Lift Cutter bar
- * Tractor counter weight maybe required

MODEL	CUTTING WIDTH	LIFT TYPE	WEIGHT	LIST PRICE
SBM006	6' / 72"	Hydraulic	576 lbs.	\$6579
SBM007	7' / 84"	Hydraulic	600 lbs.	\$6699
SBM008	8' / 96"	Hydraulic	648 lbs.	\$8199
SBM009	9' / 108"	Hydraulic	731 lbs.	\$8699

SICKLE BAR MOWER

HEAVY DUTY 3 Pt. Hitch



BEFCO'S new heavy duty sickle bar mower for 20 – 75 HP tractors has a heavier cutting bar 20mm thick with more robust guards that can handle rougher conditions. CAT.1 - 3 pt. Hitch, 540 RPM PTO shaft, comes with weight compensation spring, and a safety release latch which protects the unit from obstructions during operation. Includes a hydraulic cylinder to raise and lower cutting bar for mowing at an angle or for transport and storage. These mowers have the capabilities of mowing from 90 degrees UP to -55 degrees DOWN making it capable of handling jobs that are not recommended for conventional disc mowers.

- * Available in 72", 84" & 96" working width
- * For 20 – 75 HP Tractors
- * Cat. I - 3 Pt. hitch
- * 540 RPM PTO (cat. 4 Shaft)
- * Max. working speed 9 mph/14 kmph
- * Hydraulic (single acting) lift, with hydraulic hose and coupler
- * c/w extra knife/blade assembly and knife guard
- * c/w 6 extra knife sections and 2 extra guards

MODEL	CUTTING WIDTH	LIFT TYPE	WEIGHT	LIST PRICE
BSB272	6' / 72"	Hydraulic	628 lbs.	\$8209
BSB284	7' / 84"	Hydraulic	650 lbs.	\$8459
BSB296	8' / 96"	Hydraulic	672 lbs.	\$9379

STRING TRIMMER

Engine Driven

Walk Behind



The SWISHER walk-behind string trimmer featuring a HONDA engine is an ideal back-saving alternative to heavy hand-held gas trimmers. The trimmer's extra wide 22" cutting swath rivals that of most lawnmowers, while it's user-friendly design offers unsurpassed precision trimming performance. The trimmer features 15.75" wheels for plenty of clearance and smooth rolling over rough terrain. The trimmer line is easily replaced without the use of tools

- * 4.4HP (160cc) HONDA Engine
- * Offset fixed left
- * Two 15.75" solid tires
- * Trimmer head (2).155" strings = 4 cutting strings
- * .25 US gallon fuel capacity

MODEL	DESCRIPTION	WEIGHT	LIST PRICE
STD4422HO	160cc Push String Trimmer	84 lbs.	\$1199

OPTIONS:

MODEL	DESCRIPTION	LIST PRICE
P3618	36 pack, 18" .155 trimmer line	\$18

FINISHING MOWER

Engine Driven

Pull Type



[Click for Video](#)



SWISHER finish cut Trailmower is perfect for any large area of grass to be mowed. Backed by the power of 60 + years of design experience, this mower is designed to dramatically reduce mowing time. The SWISHER Trailmower easily attaches to your ATV, UTV or lawn tractor to cut large lawns or park areas. This trailmower is powered by a 14.5 HP Briggs & Stratton engine and gives your lawn a manicured look. A 60" side-discharge fabricated cutting deck cuts a wide swath and spreads the grass out to avoid choking. The true floating deck reduces scalping for professional mowing results, even on tricky terrain. This mower is equipped with a 12 volt key starter (12V battery not included). A universal articulating hitch attaches to any pin hitch system and lets the mower maneuver easily behind the towing vehicle.

- * 14.5 HP Briggs & Stratton Engine
- * Offset hitch, left/right/center articulating
- * Tires four 13x5x6 pneumatic tires
- * Three finishing cut blades
- * Side discharge fabricated mower deck
- * Cutting Height 1.5" – 5.5" Manual 3 point full floating deck
- * Includes front mount anti-scalping rollers
- * 2.5 US gallon fuel capacity
- * Clevis/pin type hitch
- * 12V electric start
- * Manual PTO Clutch
- * 12V battery not included

MODEL	DESCRIPTION	WEIGHT	LIST PRICE
FC14560BS	60", 14.5 HP B&S engine Electric start	353 lbs.	\$4499

FINISHING MOWERS

Engine Driven



Gas powered mowers for lawn tractors and ATV's. This three spindle finishing mower comes complete with:

- * 11.5 HP Briggs & Stratton I/C engine with centrifugal clutch
- * Rear discharge
- * Spindle shafts greased from the top for easy service
- * Two front swivel tires and two rear non-swivel tires
- * Cutting height: 1" to 4"
- * Cat. 1 ball hitch
- * Semi pneumatic tires
- * 10 gauge reinforced mower deck
- * Heavy duty reinforced belt (BX)
- * Heavy duty, one piece, balanced steel pulleys
- * Safety kill switch
- * High blade tip speed

MODEL	CUTTING WIDTH	BLADE TIP SPEED (FT/MIN)	WEIGHT	LIST PRICE
C30CE5H	60"	14,173	388 lbs.	\$4799

FINISHING MOWERS

3 Pt. Rear Discharge



These mowers are ideal for use with 540 RPM 15 – 30 HP tractors with Cat. I 3 Pt. hitch. These three blade finishing mowers with a rotor speed of 2630 RPM are available in 5' and 6' cutting width. These mowers are perfect for maintaining any type of grassy area, from your home estate to golf courses and park areas. These mowers are designed to easily adjust the cutting height, which can be changed by simply adjusting the spacers on the wheel yoke.

- * Rear Discharge with rear safety chains
- * 3" x 8" Solid Rubber Wheel/Tires
- * Floating Style Cat. I 3 Pt. Hitch
- * 540 RPM PTO
- * Powder Coat Paint
- * Deck thickness 5' - 12ga.
6' - 10ga.
- * 3 Blades with Greaseable Spindles
- * Blade tip speed 5' - 14,961 ft/min.
6' - 13,976 ft/min
- * Double V-Belt Drive
- * Cutting Height Adjustment 1-1/2" to 4-1/2"

MODEL	DESCRIPTION	WEIGHT	LIST PRICE
BFM105	5' / 60" cutting width mower	386 lbs.	\$1859
BFM106	6' / 72" cutting width mower	508 lbs.	\$2139

FINISHING MOWERS

C30 Series

Rear Discharge



Optional front anti-scalping roller

For tractors 16 to 30 HP, 540 RPM, Category 1, 3 Pt. hitch. Rear discharge, three spindle grooming mower.

- * Highly engineered & rugged gearbox with cooling fins
- * Front and rear tractor mounting
- * Four swivel 9" x 3.5" (4 ply with tubes) pneumatic tires
- * Floating 3 Pt. linkage, Cat. 1
- * 11 gauge reinforced mower deck
- * 1" to 4" cutting height
- * Spindle shafts greased from the top for easy service
- * Heavy duty reinforced belt (BX)
- * Heavy duty, one piece, balanced steel pulleys
- * High blade tip speed
- * Precise blade overlap

MODEL	CUTTING WIDTH	BLADE TIP SPEED (FT/MIN)	WEIGHT	LIST PRICE
C30RD5A	60"	14,763	364 lbs.	\$3579
C30RD6A	72"	14,566	429 lbs.	\$3899

OPTIONS:

MODEL	DESCRIPTION	LIST PRICE
001-600	Front antiscalping roller	\$175
005-600	Mulching kit for model C30RD5	\$519
006-600	Mulching kit for model C30RD6	\$559

FINISHING MOWERS

C50 Series

Rear Discharge



Floating Linkage
on 5' & 6'

[Click for Video](#)



Optional front
anti-scalping roller

C50RD7A
Shown

Ideal for tractors from 20 to 50 HP. Category 1, 3 Pt. hitch, 540 RPM. These 3 spindle **BEFCO** rear discharge mowers come complete with:

- * 1" to 5" cutting height
- * Highly engineered & rugged gear box with cooling fins
- * Heavy duty shielded PTO shaft (1-3/8" ASAE Cat. 3)
- * Four height control bearingwheels
- * Floating 3 Pt. linkage, Cat. 1
- * Spindle shafts greased from the top for easy service
- * Heavy duty, one piece, balanced steel pulleys
- * Two heavy duty reinforced belts (SPBX)
- * High blade tip speed
- * Pneumatic tires 11" x 4" (4 ply with tube)
- * 8 gauge reinforced mower deck
- * Four castor wheels
- * C50RD5 & C50RD6 mowers include standard CAT. I lower lift pins
- * C50RD7 mower includes CAT. I clevis type lower lift pins

MODEL	CUTTING WIDTH	BLADE TIP SPEED (FT/MIN)	WEIGHT	LIST PRICE
C50RD5A	60"	16,929	534 lbs.	\$4719
C50RD6A	72"	16,732	584 lbs.	\$4989
C50RD7A	84"	16,338	674 lbs.	\$5839

OPTIONS:

MODEL	DESCRIPTION	LIST PRICE
009-9915	Front anti-scalping roller for 5' and 6' mowers, standard on 7' mower	\$195
009-9815	Professional front anti-scalping roller	\$275
005-700	Mulching kit for model C50RD5	\$535
006-700	Mulching kit for model C50RD6	\$609
007-700	Mulching kit for model C50RD7	\$709

FINISHING MOWERS

C70 Series

Rear Discharge



For tractors from 30 to 70 HP, Category 1, 3 Pt. hitch, 540 RPM. These 3 spindle **BEFCO** rear discharge mowers come complete with:

- * Highly engineered & rugged gearbox with cooling fins
- * Cutting height: 1.3" to 5.3"
- * Front and rear tractor mounting
- * Four heavy duty bearing wheels
- * Floating 3 Pt. linkage, Cat. 1
- * Two heavy duty reinforced belts (CX)
- * Heavy duty shielded PTO shaft (1-3/8" ASAE Cat. 4)
- * Six free swinging kick back blades
- * Spindle shafts greased from the top for easy service
- * Heavy duty, one piece, balanced steel pulleys
- * High blade tip speed
- * Pneumatic tires 13" x 6.5" 4 ply with tubes
- * Front anti-scalping roller
- * 8 gauge reinforced mower deck
- * Optional hard rubber, semi-pneumatic tires available

MODEL	CUTTING WIDTH	BLADE TIP SPEED (FT/MIN)	WEIGHT	LIST PRICE
C70090A	90"	13,976	1137 lbs.	\$9379
C70110A	110"	14,960	1290 lbs.	\$10,929

FLEX MOWERS

Pull Type Cyclone Flex



[Click for Video](#)

For technical specifications on individual mower decks
see page 23 (C50 Mowers)

- * HP Requirements: 25-60, 540 RPM
- * Heavy duty transport frame
- * Cutting height: 1" to 5"
- * Pull type mower with high flotation transport tires (20.5" x 8"x10")
- * Single action hydraulic folding wing system for easy transport and storage
- * Transport width 7' 10" max.
- * CV driveline with slip clutch (1-3/8" ASAE Cat. 6)
- * Deck overlap adjustment 6"
- * Three front anti-scalping rollers standard
- * Safety chain shield standard
- * Remote safety locks for transporting
- * Each mower deck has four 11" x 4" (4 ply pneumatic tires & tubes)
- * Optional hard rubber, semi-pneumatic tire for mower decks available. Specify at time of order

MODEL	CUTTING WIDTH	UNIT MAKE UP	WEIGHT	LIST PRICE
312FLXA	12'	(2) FX4 & (1) FX5	2694 lbs.	\$25,649
315FLXA	15'	(2) FX5 & (1) FX6	2826 lbs.	\$27,999
317FLXA	17'	(3) FX6	2947 lbs.	\$29,089

OPTIONS:

MODEL	DESCRIPTION	LIST PRICE
009-9556	Mulching kit for model 312-FLX (3 units)	\$1579
009-9557	Mulching kit for model 315-FLX (3 units)	\$1729
009-9558	Mulching kit for model 317-FLX (3 units)	\$1889
009-9817	Hydraulic unlocking system	\$849
009-9597	Floating hitch	\$389

Weights indicated are base machine weight, not shipping weight

FLEX MOWERS

Super-Flex Pull Type



[Click for Video](#)

For technical specifications on individual mower decks
see page 23 (C50 Mowers)

- * HP Requirements: 35-80, 540 RPM
- * Extra heavy duty transport frame
- * 1" to 5" cutting height
- * Pull type mower with high flotation transport tires (23" x 10.5" x 12")
- * Single action hydraulic folding wing system for easy transport and storage
- * Three front anti-scalping rollers standard
- * CV driveline with slip clutch (1-3/8" ASAE Cat. 6)
- * Deck overlap adjustment 6"
- * Safety chain shield standard
- * Remote safety locks for transporting
- * Each mower deck has four 13" x 6.5" (4 ply air tires with tubes)

MODEL	CUTTING WIDTH	UNIT MAKEUP	WEIGHT	LIST PRICE
412SFLA	12'	(2) SF4 & (1) SF5	3090 lbs.	\$29,999
415SFLA	15'	(2) SF5 & (1) SF6	3267 lbs.	\$31,689
417SFLA	17'	(3) SF6	3438 lbs.	\$34,359
420SFLA	20'	(3) SF7	3747 lbs.	\$38,779

OPTIONS:

MODEL	DESCRIPTION	LIST PRICE
009-9556	Mulching kit for model 412-SFL (3 units)	\$1579
009-9557	Mulching kit for model 415-SFL (3 units)	\$1729
009-9558	Mulching kit for model 417-SFL (3 units)	\$1889
009-9559	Mulching kit for model 420-SFL (3 units)	\$2199
009-9817	Hydraulic unlocking system	\$849
009-9597	Floating hitch	\$399

FLAIL MOWERS

H40 Series, Hurricane



For tractors from 15 to 40 HP, Category 1, 3 Pt. hitch, 540 RPM. Flail mowers come complete with:

- * 1" to 5" cutting height
 - * Two heavy duty reinforced notched belts (SPBX)
 - * Highly engineered & rugged gearbox with cooling fins
 - * High blade tip speed
 - * Adjustable cutting height roller
 - * Perfectly balanced rotor
 - * Two pc. regular cut knives - Optional
 - * Two pc. fine cut knives - Standard
 - * Clockwise rotation is standard
 - * Offset from center: 3" on H40-048
8.5" on H40-060
6.5" on H40-072
 - * Front rubber safety shielding
 - * Optional hammer type blades available in lieu of standard blades
- ***Specify at time of order

CUTTING STANDARD					LIST
MODEL	WIDTH	# BLADES	OFFSET	WEIGHT	PRICE
H40-048	48"	48	3"	418 lbs.	\$4569
H40-060	60"	64	8.5"	456 lbs.	\$4899
H40-072	72"	76	6.5"	528 lbs.	\$5389

OPTIONS:

MODEL	DESCRIPTION	LIST PRICE
009-9507	Side skid shoes (pair)	\$159
009-9200	*Hammer type blades for model H40-048	\$389
009-9201	*Hammer type blades for model H40-060	\$509
009-9202	*Hammer type blades for model H40-072	\$609

In lieu of standard blades
*Specify at time of order

FLAIL MOWERS

H70 Series, Hurricane



[Click for Video](#)



For tractors from 30 to 70 HP, Category 1, 3 Pt. hitch, 540 RPM. Flail mowers come complete with:

- * 3/4" to 6" cutting height
 - * Front & rear tractor mounting
 - * Adjustable cutting height roller with scraper
 - * High blade tip speed
 - * Heavy duty shielded PTO shaft with over running clutch (1-3/8" ASAE Cat. 4).
 - * Highly engineered & rugged gearbox
 - * Electronically balanced rotor
 - * Two heavy duty reinforced notched belts (CX)
 - * Semi-automatic belt tensioner
 - * Floating top link
 - * Sealed rotor bearings
 - * Fine cut (2 Pc) knives-standard
 - * Regular cut (2 pc reversible Y) knives - Optional
 - * Forward rotor rotation is standard
 - * Reverse rotor rotation is optional (Extra)
 - * Rotor RPM: 2080
 - * Blade tip speed (ft/min): 8464
 - * Optional hammer type blades available in lieu of standard blades
- ***Specify at time of order

MODEL	CUTTING WIDTH	OVERALL WIDTH	# BLADES	WEIGHT	LIST PRICE
H70-060	60"	71"	64	869 lbs.	\$9139
H70-072	72"	85"	80	955 lbs.	\$9769
H70-088	88"	99"	96	1078 lbs.	\$10,399

OPTIONS:

MODEL	DESCRIPTION	LIST PRICE
009-9691	Gauge wheels with laminated tires (pair)	\$1439
009-9201	*Hammer type blades for model H70-060	\$509
009-9203	*Hammer type blades for model H70-072	\$619
009-9204	*Hammer type blades for model H70-088	\$739

In lieu of standard blades
*Specify at time of order

FLAIL MOWERS

H80 Series

Hurricane Commercial



[Click for Video](#)



Ideal for tractors from 50 to 80 HP, Category 1 and 2, 3 Pt. hitch, 540 RPM. Flail mowers come complete with:

- * 3/4" to 6" cutting height
 - * Frame thickness: 8 gauge
 - * Side plates thickness: 5/16"
 - * Rotor diameter: 6"
 - * Rotor wall thickness: 3/8"
 - * Regular cut (2 pc. reversible Y) blades - standard
 - * Fine cut (2 pc.) blades - optional
 - * High blade tip speed
 - * Adjustable cutting height roller with scraper
 - * Highly engineered gearbox
 - * Front & rear tractor mounting
 - * Electronically balanced rotor
 - * Heavy duty, one piece, balanced steel pulleys
 - * Two heavy duty reinforced notched belts (CX)
 - * 3 Pt. linkage, Cat. 1 and 2
 - * Floating top link
 - * Forward rotor rotation is standard
 - * Reverse rotor rotation is optional (Extra)
 - * Replaceable skid shoes
 - * Semi-automatic belt tensioner
 - * Sealed 2" rotor bearings
 - * Driveline with over-running clutch (1-3/8" ASAE Cat. 6)
 - * Rotor RPM: 1873
 - * Blade tip speed (ft/min): 8268
 - * Optional hammer type blades available in lieu of standard blades
- ***Specify at time of order

MODEL	CUTTING WIDTH	OVERALL WIDTH	# BLADES	WEIGHT	LIST PRICE
H80-100	100"	110"	104	1486 lbs.	\$14,999

OPTIONS:

MODEL	DESCRIPTION	LIST PRICE
009-9701	Gauge wheels with laminated tires (pair)	\$1699
009-9205	*Hammer type blades for model H80-100 In lieu of standard blades *Specify at time of order	\$799

Weights indicated are base machine weight, not shipping weight

FLAIL SHREDDER

Destroyer Series



[Click for Video](#)

New from BEFCO a heavy duty Flail shredder, with hydraulic side shift. Available in three sizes 60", 72", and 88". Comes standard with Cat. I & II rear mounted 3 Pt. hitch. Heavy duty hammer type blades that can shred material up to 2" thickness. Horse power recommended 40- 90.

- * Cat. I & II Rear Mount 3 Pt. Hitch
- * 540 RPM PTO with Overrunning Clutch is standard
- * 4 Belt Driven Transmission, with Manual Belt Tensioner
- * Hydraulic Side Shift (Offset) 12" on 60" model & 16" on 72" & 88" models
- * Heavy Duty Hammer Type blades
- * Rotor Diameter 133mm(5-1/4"), 8mm(1/4") thick tube
- * Height adjustment via rear roller, with scraper
- * Rear Roller Diameter 168mm(6-1/2"), 4.5mm(3/16") thick tube

MODEL	D90-060	D90-072	D90-088
WORKING WIDTH	60"	72"	88"
OVERALL WIDTH	69"	81"	96"
WEIGHT	1257 lbs.	1345 lbs.	1491 lbs.
# OF HAMMERS	16	20	24
HYD SIDE SHIFT	12"	16"	16"
CUTTING CAPACITY	2"	2"	2"
PRICE	\$11,659	\$12,359	\$12,999

OPTIONS:

MODEL	DESCRIPTION	LIST PRICE
009-9968	*Dual PTO gear box and front mount 3 Pt. hitch (Factory Installed)	\$509
009-9969	Skid shoes (pair)	\$339

*Specify at time of order

ROTARY TILLER

Engine Driven - Pull Type

Agri-Fab
Lawn Care Made Easy

[Click for Video](#)



The Agri-Fab Multi-Fit tow behind rotary tiller comes with a 6.5 HP B&S Intek engine and has a 36" tilling width with conveniently located controls. Quickly prepare the perfect planting bed with minimal effort. Can be used with any ATV or garden tractor above 12 HP.

- * 163cc B&S Engine with 2 year warranty
- * Recoil start
- * 36" Tilling width
- * Forward rotating tines
- * Six double edge 11" diameter heavy duty tines
- * Tilling depth adjustable from 1-1/2" to 5-1/2"

MODEL	DESCRIPTION	WEIGHT	LIST PRICE
450308	Pull type - 36"	229 lbs.	\$2099

ROTARY TILLERS

Manual Side-Shift



The **ROTOMECH** tiller is a rugged machine with an extremely simple and functional side shift at no additional charge. Ideal for tractors ranging from 20 to 40 HP. Tillers come complete with:

- * Highly engineered and rugged gearbox
- * Four knives per flange
- * Solid rotor shaft
- * Heavy duty tiller blades
- * Shielded shear pin PTO
- * Cat I 3 Pt. hitch
- * Reinforced lateral 80 ASA chain drive transmission in oil bath
- * Adjustable skids for depth control
- * Exchangeable sprockets for 2 rotor speeds, 231/375 RPM
- * Working Depth up to 7 1/4"

WORKING						LIST
MODEL	WIDTH	OFFSET	# FLANGES	# KNIVES	WEIGHT	PRICE
142-231	42"	10"	5	20	373 lbs.	\$3169
150-231	50"	14"	6	24	407 lbs.	\$3269
158-231	58"	18"	7	28	452 lbs.	\$3449
166-231	66"	22"	8	32	492 lbs.	\$3719

ROTARY TILLERS

T30 Series

Manual Side-Shift



For tractors from 18 to 30 HP. Category 1, 3 Pt. hitch, 540 RPM PTO. T30 series tillers come complete with:

- * HP Requirements: 16-30, 540 RPM
- * Highly engineered and rugged gearbox with cooling fins
- * Four blades per flange
- * High carbon solid steel round rotor shaft allows for a deeper working depth
- * Heavy duty full size blades
- * Heavy duty shielded PTO shaft with shear pin coupling (1-3/8" ASAE Cat. 2)
- * # 60 chain drive
- * Adjustable side skids for working depth control

MODEL	WORKING				WEIGHT	LIST PRICE
	WIDTH	OFFSET	# FLANGES	# BLADES		
T30-134	34"	6"	4	16	297 lbs.	\$3099
T30-142	42"	10"	5	20	341 lbs.	\$3189
T30-150	50"	14"	6	24	374 lbs.	\$3369

OPTIONS:

MODEL	DESCRIPTION	LIST PRICE
009-9538	Cat. 0, 3 Pt hitch (Specify at time of ORDER)	\$239

Specify at time of order

ROTARY TILLERS

T40 Series

Manual Side-Shift



For tractors up to 40 HP. Category 1, 3 Pt. hitch, 540 RPM PTO. T40 series tillers come complete with:

- * Highly engineered and rugged gearbox
- * Four blades per flange
- * Solid steel rotor shaft
- * Adjustable side skirts for working depth control
- * Wear protection on chain case
- * Heavy duty full size blades
- * Heavy duty shielded PTO shaft with slip clutch safety (1-3/8" ASAE Cat. 3)
- * # 80 chain drive with exchangeable sprockets for 2 rotor speeds, 231/375 RPM

	WORKING					LIST
MODEL	WIDTH	OFFSET	# FLANGES	# BLADES	WEIGHT	PRICE
T40-242	42"	10"	5	20	373 lbs.	\$3959
T40-250	50"	14"	6	24	417 lbs.	\$4119
T40-258	58"	18"	7	28	461 lbs.	\$4259
T40-266	66"	22"	8	32	530 lbs.	\$4679

ROTARY TILLERS

T50 Series

Manual Side-Shift



For tractors up to 50 HP. Category 1, 3 Pt. hitch, 540 RPM PTO. T50 series tillers come complete with:

- * HP Requirements: 25-50, 540 RPM
- * Highly engineered and rugged gearbox
- * Six blades per flange for greater stability & finer soil pulverization
- * Solid steel rotor shaft
- * Heavy duty shielded PTO with shaft with slip clutch safety (1-3/8" ASAE Cat. 4)
- * Heavy duty full size tiller blades
- * Wear protection on chain case
- * Adjustable side skirts for working depth control
- * Lateral #100 Roller Chain drive transmission in oil bath
- * Exchangeable sprockets for two rotor speeds 226/383 RPM
- * Max. working depth 8-3/8"

	WORKING					LIST
MODEL	WIDTH	OFFSET	# FLANGES	# BLADES	WEIGHT	PRICE
T50-350	50"	14"	6	36	481 lbs.	\$4949
T50-358	58"	18"	7	42	528 lbs.	\$5119
T50-366	66"	22"	8	48	575 lbs.	\$5389

Weights indicated are base machine weight, not shipping weight

ROTARY TILLERS

T60 Series

Manual Side-Shift



For tractors up to 60 HP. Category 1, 3 Pt. hitch, 540 RPM PTO. T60 series tillers come complete with:

- * HP Requirements: 30-60, 540 RPM
- * Highly engineered and rugged gearbox
- * Six blades per flange for greater stability & finer soil pulverization
- * Solid steel rotor shaft
- * Heavy duty full size tiller blades
- * Wear protection on chain case
- * Adjustable side skids for working depth control
- * # 100 chain drive in oil bath
- * Heavy duty shielded PTO shaft with slip clutch safety (1-3/8" ASAE Cat.6)
- * Max. working depth 8-3/8"

MODEL	WORKING WIDTH	OFFSET	# FLANGES	# BLADES	WEIGHT	LIST PRICE
T60-366	66"	22"	8	48	740 lbs.	\$6729
T60-374	74"	26"	9	54	798 lbs.	\$6999

ROTARY TILLERS

T70 Series



For tractors up to 70 HP. Category 1, 3 Pt. hitch, 540 RPM PTO. T70 series tillers come complete with:

- * HP Requirements: 30-70, 540 RPM
- * Heavy duty reinforced frame
- * Six blades per flange for greater stability & finer soil pulverization
- * Max working depth 8-3/4"
- * Wear protection on chain case
- * Heavy duty shielded PTO shaft with slip clutch safety (1-3/8" ASAE Cat.6)
- * Adjustable side skids for working depth control
- * Flanged rotor shaft for easy removal & service
- * Solid steel rotor shaft
- * Heavy duty gearbox
- * # 100 chain drive transmission in oil bath

MODEL	WORKING WIDTH	OFFSET	# FLANGES	# BLADES	WEIGHT	LIST PRICE
T70-382	82"	22"	10	60	879 lbs.	\$7329

Weights indicated are base machine weight, not shipping weight

AERATOR / OVERSEEDER

Green-Rite



For tractors from 25 to 70 HP. Category 1, 3 Pt. hitch. 540 RPM PTO. **BEFCO** Green-Rite Overseeders/Primary seeders come complete with:

- * **HP Requirements: 25-70, 540 RPM**
- * **Series T40 rotary tiller base machine on 50", 58", 66" and T70 on 82"**
- * **Special 2.8" flange spacing on rotor for aerating with 3 knives per flange on GRT250, GRT258 & GRT266**
- * **4 knives per flange on GRT288**
- * **Straight aerator knives**
- * **Seed covering/dethatching adjustable tickler tines**
- * **Seed hopper with metering cups**
- * **Ground drive system for seed hoppers**
- * **Corrugated depth control roller made with low weight nylon/fiberglass roller rings**
- * **Heavy duty shielded PTO shaft with slip clutch safety**

MODEL	WORKING WIDTH	HOPPER CAP. CU. FT.	# FLANGES	# BLADES	WEIGHT	LIST PRICE
GRT250	50"	4.60	15	43	910 lbs.	\$12,599
GRT258	58"	5.30	18	52	998 lbs.	\$12,959
GRT266	66"	6	21	61	1170 lbs.	\$14,539
GRT282	82"	7.6	26	104	1500 lbs.	\$18,739

NOTE: Units may utilize gauge wheels or a gauge roller for blade depth control, but not both.

OPTIONS:

MODEL	DESCRIPTION	LIST PRICE
009-9875	Gauge wheels for all models	\$579
009-9648	Front roller for GRT-250	\$919
009-9516	Front roller for GRT-258	\$969
009-9563	Front roller for GRT-266	\$1049
009-9566	Front roller for GRT-282	\$1129
009-9649	Tiller rotor for GRT-250	\$900
009-9517	Tiller rotor for GRT-258	\$1029
009-9564	Tiller rotor for GRT-266	\$1139
009-9567	Tiller rotor for GRT-282	\$2119
009-9650	Rear roller scraper for GRT-250	\$319
009-9539	Rear roller scraper for GRT-258	\$369
009-9565	Rear roller scraper for GRT-266	\$509
009-9568	Rear roller scraper for GRT-282	\$579

SEEDER/OVERSEEDER SEED-RITE



The BEFCO Seed-Rite is a primary full width seeder / overseeder. 74" working width, with a ground drive system for seed hopper. Steel seed box comes with a steel shaft agitator with ten high precision metering seed cups, with a wide range of calibration settings per acre. Two nylon/fiberglass corrugated rollers 9-1/2" in diameter the working width of seeder compact seed into soil. Unit can also be used as an overseeder for seeding existing lawns, parks etc.

- * **Cat. I, 3 Pt. Hitch (quick hitch compatible)**
- * **Parking stands**
- * **74" seeding width**
- * **80" overall width**
- * **Heavy duty frame**
- * **Heavy duty seed box lid with seed splash guard**
- * **Seed box capacity 7 cu.ft.(5-1/2 Bu.)**
- * **Seed box agitator**
- * **10 high precision metering seed cups**
- * **Wind guarded seed drop**
- * **Two 9-1/2" diameter nylon/fiberglass corrugated rollers**
- * **Greaseable roller bearings**
- * **Two spring tine track removers**

MODEL	DESCRIPTION	WEIGHT (LBS.)	LIST PRICE
SRT074	74" Seed-Rite Seeder/Overseeder	990 lbs.	\$8399

OPTIONS:

MODEL	DESCRIPTION	LIST PRICE
009-9930	Rear Expanded Roller Frame with Adjustable Tickler Tines for Seed Covering & De-thatching	\$829

SOIL-PULVERIZERS



- * 3/8" steel spikes fully welded in a timed scroll pattern
- * 10" frame beam (Standard)
- * 12" frame beam (Heavy Duty)
- * Two rows heavy duty reversible heat treated scarifier shanks
- * 5-9/16" dia. spiked roller tube (Standard)
- * 6-5/8" dia. spiked roller tube (Heavy Duty)

- * Complete with two 160 lbs. compression roller springs
- * Optional 2nd spiked roller available with 2-80 lb. compression
- * Reversible heat treated 1/2" x 2" shanks
- * 4-1/2" shank penetration
- * 3 Pt. linkage, Cat. 1
- * Self aligning 1" bearing on roller
- * Formed plate "A" frame
- * Shank spacing 2-13/16"

STANDARD

MODEL	WORKING WIDTH	WEIGHT	# SHANKS	# ROLLER SPIKES	LIST PRICE
BPL048	48"	496 lbs.	17	70	\$2729
BPL060	60"	652 lbs.	21	88	\$2919
BPL072	72"	679 lbs.	25	106	\$3199

HEAVY DUTY

MODEL	WORKING WIDTH	WEIGHT	# SHANKS	# ROLLER SPIKES	LIST PRICE
BPL284	84"	875 lbs.	29	124	\$4359

OPTIONS:

Add-on double roller includes bracket & bearings

MODEL	DESCRIPTION	LIST PRICE
009-9887	48" x 5" dia. for BPL048	\$769
009-9636	60" x 5" dia. for BPL060	\$889
009-9637	72" x 5" dia. for BPL072	\$1089
40 009-9647	84" x 5-9/16" dia. for BLP284	\$1359

Weights indicated are base machine weight, not shipping weight

CORE AERATORS

Standard/Heavy Duty



The BEFCO Core Aerators are designed to allow better air and water penetration in grass surfaces such as lawns, sports fields, municipal parks and golf courses. These aerators use $\frac{3}{4}$ " case hardened closed spoons, bolted on rotor flanges that are spaced $6\frac{1}{2}$ " apart. SD units have 6 spoons per hub, while HD models have 8 spoons per hub, which can penetrate heavy thatch and tough soils to break up compaction and revitalize grassed areas. SD models are available in 48", 60", and 72" working widths, and compatible with 20 to 50 HP tractors. HD models are available in 60" and 72" working widths, and compatible with 20 to 70 HP tractors.

- * CAT. 1 3 Pt. Hitch (Standard)
- * CAT. 1&2, 3 Pt. Hitch (HD)
- * 8 gauge formed steel construction
- * 1-1/4" rotor support shaft
- * Hub spacing 6.5"
- * 3/4" hardened steel spoons
- * Front or rear tractor mounting
- * High tensile steel rotor shafts
- * Flanges/Hubs welded to rotor
- * 6 spoons per hub (Standard)
- * 8 spoons per hub (Heavy Duty)
- * 3 support stands

Standard

MODEL	WORKING WIDTH	# OF HUBS	# OF SPOONS	SPOON PENETRATION	WEIGHT	LIST PRICE
BCA048	48"	8	48	4-1/2"	284 lbs	\$3199
BCA060	60"	10	60	4-1/2"	357 lbs	\$3349
BCA072	72"	12	72	4-1/2"	401 lbs	\$3619

Heavy Duty

MODEL	WORKING WIDTH	# OF HUBS	# OF SPOONS	SPOON PENETRATION	WEIGHT	LIST PRICE
BCA260	60"	10	80	4-1/2"	444 lbs	\$4249
BCA272	72"	12	96	4-1/2"	549 lbs	\$4699

Units available with Spikes (EXTRA) in lieu of spoons
 Optional steel weight tanks for sand available

P.O.R.

REAR SCRAPER BLADES 3 Pt. 4100 Series



These affordable 3 Pt. rear scraper blades built by TITAN Implement are ideal attachment for tractors up to 45 HP. They have a reversible and a replaceable 6" cutting edge. They have a quick and easy left or right angle ability in forward or reverse position. Manufactured in U.S.A.

- * Cat. I – 3 Pt. Hitch
- * Rated for tractors 15 to 45 HP
- * Available in 4', 5', 6' & 7' working widths
- * Moldboard height 4' & 5' – 13" high , 6' & 7' – 14" high
- * 6" reversible & replaceable cutting edge
- * Angle adjustment 5 positions forward & reverse
- * Quick hitch compatible

MODEL	WIDTH	WEIGHT	LIST PRICE
4104	4' / 48" working width	158 lbs.	\$479
4105	5' / 60" working width	179 lbs.	\$499
4106	6' / 72" working width	202 lbs.	\$579
4107	7' / 84" working width	223 lbs.	\$669

REAR SCRAPER BLADES 3 Pt. 4400 Series



These affordable 3 Pt. rear scraper blades built by TITAN Implement are ideal attachment for tractors up to 65 HP. They have a reversible and a replaceable 6" cutting edge. They have a quick and easy left or right angle ability in forward or reverse position. They also offer offset and tilt adjustment. Manufactured in U.S.A.

- * Cat. I – 3 Pt. Hitch
- * Rated for tractors 35 to 65 HP
- * Available in 5', 6' & 7' working widths
- * Moldboard height 15.5" high
- * 6" reversible & replaceable cutting edge
- * Angle adjustment 5 positions forward & reverse
- * Tilt adjustment 3 positions
- * Offset adjustment 5 positions
- * Quick hitch compatible

MODEL	WIDTH	WEIGHT	LIST PRICE
4405	5' / 60" working width	323 lbs.	\$979
4406	6' / 72" working width	340 lbs.	\$1039
4407	7' / 84" working width	358 lbs.	\$1139

REAR SCRAPER BLADES

Heavy Duty



These heavy duty rear scraper blades are designed to give you the quality, dependable performance that you require. They come with Category 1 and 2, 3 Pt. hitch for 35 to 85 HP. These units come equipped with quick tilt, angle and offset manual adjustments. A parking stand is standard.

- * **HP Requirements: 35-85**
- * **Tilt adjustments: 15-16° right or left**
- * **Offset adjustments: 15-30° right or left**
- * **Moldboard thickness: 1/4"**
- * **Moldboard height: 17"**
- * **Reversible 1/2" x 6" cutting edge**
- * **Angle adjustment 15° - 16° - 45° forward or reverse**
- * **Cat. 1 and 2, 3 Pt. hitch**

MODEL	WIDTH	WEIGHT	LIST PRICE
GB484	7'	576 lbs.	\$2779
GB496	8'	652 lbs.	\$2889

SCRAPER BLADE HD HYDRAULIC 3 Pt.



These heavy duty 3 pt. hitch rear scraper blades come standard with one hydraulic cylinder (with hydraulic hoses) for angling. They can offset and tilt manually, an optional hydraulic tilt kit is available. The blade cannot be reversed to push. These blades are built heavy to handle your roughest conditions.

- * Cat II 3 Pt. hitch
- * 90 HP rated
- * 19" high moldboard
- * 1/4" thick moldboard
- * 6" reversible cutting
- * Comes with hydraulic hoses & coupler plugs
- * Angles Hydraulically
- * Offsets & tilts manually
- * Optional hydraulic tilt kit available

MODEL	DESCRIPTION	WEIGHT	LIST PRICE
BRB908	8'/96" 3 Pt. HD Scraper Blade	904 lbs.	\$3199
BRB909	9'/108" 3 Pt. HD Scraper Blade	1050 lbs.	\$3499

OPTIONS:

MODEL	DESCRIPTION	WEIGHT	LIST PRICE
BRB009HC	Hydraulic Tilt Kit (Includes hydraulic cylinder & hoses)	28 lbs.	\$729

GRADER BLADE SKID STEER



[Click for Video](#)

The WORKSAVER 8 ft. six-way hydraulically controlled Skid Steer blade is controlled by an in-cab remote. The moldboard is shear pin protected to help prevent damage if an object is struck. The hydraulic cylinders work independently to allow the operator to adjust the moldboard to the task at hand. A proportional hydraulic valve provides precise control for maintaining grade. For even finer grade control, the unit can be paired with a Leica Laser System (sold separately). Flotation tires keep the machine moving smoothly over the worksite. In-cab controls allow the operator to adjust the angle and tilt functions from their seat. The SSGB8B is the perfect tool for maintaining a consistent grade when doing site prep work.

- * **15" high x 8 ft. long Moldboard**
- * **Moldboard is shear pin protected**
- * **1/2" x 6" reversible steel cutting edge**
- * **25 degree moldboard rotation**
- * **25 degree moldboard tilt**
- * **Large 18.5 x 8.5 x 8 tires**
- * **Greaseable tapered roller wheel bearings**
- * **Hardened steel bushings used on main pivot points**

MODEL	DESCRIPTION	WEIGHT	LIST PRICE
SSGB8B	8' Hydraulic skid steer mounted grader blade	1195 lbs.	\$15,839

OPTIONS:

MODEL	DESCRIPTION	WEIGHT	LIST PRICE
2507020	Laser Interface Junction Box Kit Allows the SSGB8B to interface with Leica Laser System (purchased separately from Leica)	3 lbs.	\$999
812110	Laser Poles (Pair)	30 lbs.	\$249
811980	End Plates for blade (Pair)	60 lbs.	\$449

Special Order, Allow 30 days for delivery

LAND PLANES

LP Series



Tufline's LP Series land planes are ideal for gravel road reconditioning, driveway grading, pot hole filling, and general land levelling and grading. The LP series offers high strength reversible, double bevel cutting edges for unique dual blade grading performance. Constructed of heavy 3" square tubing, 3/16" thick plate & channel make the main frame rugged. Models 5' & 6' are Cat. I, 3 Pt. hitch. Models 7' & 8' are Cat. I - II, 3 Pt. hitch.

MODEL	WIDTH	WEIGHT	LIST PRICE
LP160	5'	482 lbs.	\$1939
LP172	6'	532 lbs.	\$2069
LP184	7'	598 lbs.	\$2179
LP196	8'	642 lbs.	\$2339

LP3 Series Heavy Duty



The LP3 series comes with two 1/2" x 6" cutting blades, with removal, rugged scarifiers to rip up any hard compacted ground. Then finish it with a smooth grade to flatten and level the soil. Constructed of 4" x 4" x 3/8" thick square tubing, along with 60" x 20" x thick side plates with adjustable skid shoes to set grading depth. Cat. I & II 3 Pt. hitch, quick hitch adaptable.

MODEL	WIDTH	SHANKS	WEIGHT	LIST PRICE
LP384	7'/84"	4	908 lbs	\$4199
LP396	8'/96"	6	1110 lbs	\$4429
LP3120	10'/120"	8	1254 lbs.	\$4799

Weights indicated are base machine weight, not shipping weight

SNOW BLADES SKID STEER & FRONT TRACTOR LOADERS

5' & 6' Working Widths



[Click for Video](#)

- * Recommended HP 25 - 45
- * Maximum operating weight 4,500 lbs.
- * 2 trip springs for controlled break over in snow
- * Blade locks for light grading of loose dirt or gravel
- * 3/8" x 6" reversible hardened steel cutting edge
- * 6" x 1/2" thick rotating height adjustable skid shoes
- * 21" high moldboard
- * Manual angle adjustment is standard
- * Optional hydraulic angle adjustment kit available

MODEL	DESCRIPTION	WEIGHT	PRICE
SBS2160	5 ft. snow blade for compact tractors with loaders that utilize the "Universal" skid steer quick attach system	325 lbs.	\$2979
SBFL2160	5 ft. snow blade for compact tractors with loaders requiring optional interfacing quick attach brackets. Order extra	335 lbs.	\$2899
SBS2172	6 ft. snow blade for compact tractors with loaders that utilize the "Universal" skid steer quick attach system	353 lbs.	\$3079
SBFL2172	6ft. Snow blade for compact tractors with loaders requiring optional interfacing quick attach brackets. Order extra	360 lbs.	\$2949

OPTIONS:

MODEL	DESCRIPTION	WEIGHT	LIST PRICE
360170	Optional hydraulic angle adjustment kit includes cylinders, fittings and hoses between cylinders. Does NOT INCLUDE hydraulic hoses or quick couplers to tractor remotes	40 lbs.	\$609
360065	Optional crossover relief valve protects blade from damage	7 lbs.	\$409
360220	Optional top deflector for 5ft blade		\$189
360223	Optional top deflector for 6ft blade		\$215
360235	Optional sight indicators		\$59

SNOW BLADES SKID STEER & FRONT TRACTOR LOADERS

7.5' & 9' Working Widths



[Click for Video](#)

- * Recommended HP 40 - 90
- * 2 trip springs for controlled break over in snow
- * Blade locks for light grading of loose dirt or gravel
- * 3/8" x 6" reversible hardened steel cutting edge
- * 6" x 1/2" thick rotating height adjustable skid shoes
- * 27" high moldboard
- * 5 degree lateral oscillation
- * Manual angle adjustment is standard 7.5 ft model
- * Optional hydraulic angle kit available for 7.5 ft model
- * Hydraulic angle adjustment standard on 9 ft model

MODEL	DESCRIPTION	WEIGHT	PRICE
SBS2790A	7.5 ft. snow blade for tractors with loaders or skid steers that utilize the "Universal" skid steer quick attach system	646 lbs.	\$4069
SBFL2790A	7.5 ft. snow blade for tractors with loaders requiring optional interfacing quick attach brackets. Order extra	660 lbs.	\$3979
SBS27108A	9 ft. snow blade for tractors with loaders or skid steers that utilize the "Universal" skid steer quick attach system Includes hydraulic angle kit with cross over relief valve	735 lbs.	\$5689
SBFL27108A	9 ft. snow blade for tractors with loaders requiring optional interfacing quick attach brackets. Order extra Includes hydraulic angle kit with cross over relief valve	748 lbs.	\$5689

OPTIONS:

MODEL	DESCRIPTION	WEIGHT	LIST PRICE
360168	Optional hydraulic angle adjustment kit includes cylinders, fittings and hoses between cylinders. Does NOT INCLUDE hydraulic hoses or quick couplers to tractor remotes	40 lbs.	\$525
360065	Optional crossover relief valve protects blade from damage	7 lbs.	\$399
360227	Optional top deflector for 7.5 ft blade		\$249
360230	Optional top deflector for 9 ft blade		\$299
360235	Optional sight indicators		\$59

Weights indicated are base machine weight, not shipping weight

SNOW PUSHER 20 SERIES

"Universal" Skid Steer Mount



WORKSAVER 20-Series Snow Pusher makes snow removal easy. Performance matched to fit Sub-Compact tractors up to 30 HP, the 20-Series snow pushers are sized to the tractor for maximum snow removal. Available in 4' or 5' widths, these pushers are offered with an alloy steel cutting edge. CNC formed 11-gauge moldboard with formed 10-gauge back brace for strength and durability make these snow pushers high performers.

- * 11 gauge moldboard
- * 7 gauge end plate
- * Inside angle bracing
- * Adjustable skid shoes
- * Up to 30 HP rating
- * "Universal" skid steer style mount
- * Optional pull-back kits available
- * Models available with rubber cutting edge

MODEL	DESCRIPTION	WEIGHT	PRICE
SPS2048M	4' / 48" Snow Pusher	163 lbs.	\$1259
SPS2060M	5' / 60" Snow Pusher	180 lbs.	\$1299

OPTIONS:

MODEL	DESCRIPTION	WEIGHT	LIST PRICE
358200	48" pull back kit	63 lbs.	\$439
358205	60" pull back kit	79 lbs.	\$549

SNOW PUSHER 36 SERIES

Skid Steer and Euro/Global/Alo
Tractor Loader Mount



[Click for Video](#)

Designed for Skid Steers and Tractors equipped with a loader, the WORKSAVER 36 series Snow Pushers are job matched to the tractor for maximum performance. 2 size models are available with the "universal" skid steer or with Euro/Global/Alo attach method. Available in widths of 8' and 10', these snow pushers are offered with a 1.5" x 8" reversible premium rubber cutting edge. A CNC formed 7 gauge moldboard with two 4" industrial C channel bracing on the backside for strength and durability. 36" x 36" end plates of 5/16" material help retain snow as it is pushed forward without leaving a windrow. 4" wide adjustable skid shoes are standard equipment.

- * 7 gauge moldboard
- * Two 4" industrial C channel provides solid support
- * 36" high x 36" x 5/16" deep pusher sides
- * Comes with 1-1/2" x 8" reversible rubber cutting
- * Adjustable 4" x 36" skid shoes
- * "Universal" skid steer for easy attaching to skid steer & compact tractor loaders
- * Euro/Global/Alo quick attach for tractor loaders
- * Designed for tractor loaders & skid steers 50-90 HP

MODEL	DESCRIPTION	WEIGHT	PRICE
SPS3696R	8' / 96" Snow Pusher with universal skid steer quick attach	815 lbs.	\$4289
SPS36120R	10' / 120" Snow Pusher with universal skid steer quick attach	905 lbs.	\$4589
SPG3696R	8' / 96" Snow Pusher with Euro / Alo quick attach	810 lbs.	\$4289
SPG36120R	10' / 120" Snow Pusher with Euro / Alo quick attach	900 lbs.	\$4589

OPTIONS:

MODEL	DESCRIPTION	WEIGHT	LIST PRICE
358120	Pull-Back kit for 8ft pusher	190 lbs.	\$1259
358125	Pull-Back kit for 10ft pusher	230 lbs.	\$1479

Weights indicated are base machine weight, not shipping weight

BOX SCRAPERS

Standard Duty 3 Pt.

3100 Series



These affordable 3 Pt. box scraper blades built by TITAN Implement are ideal attachment for tractors up to 55 HP. They have a reversible and a replaceable 6" cutting edge. They come with scarifier shanks to help breakup hard packed ground. Manufactured in U.S.A.

- * Cat. I – 3 Pt. Hitch
- * Rated for tractors 15 to 55 HP
- * Available in 4', 5', 6', 7', & 8' working widths
- * Moldboard height 17" high
- * Overall depth 22"
- * 6" reversible & replaceable cutting edge
- * Quick hitch compatible

MODEL	WIDTH	# SCARIFIERS	WEIGHT	LIST PRICE
3104	4' / 48" working width	3	290 lbs.	\$899
3105	5' / 60" working width	4	323 lbs.	\$1039
3106	6' / 72" working width	5	357 lbs.	\$1169
3107	7' / 84" working width	6	390 lbs.	\$1319
3108	8' / 96" working width	6	421 lbs.	\$1399

BOX SCRAPERS

Heavy Duty



These heavy duty series of box scrapers are available in widths up to 8'. They are ideal for the professional landscaper or farmer. They come complete with hinged rear moldboard for smoother grading and front and rear cutting edge with scarifier shanks. Category 1 pins on 5' and 6' models. Category 2 pins on 7' and 8' models. Horsepower rating of 30 to 90 HP.

- * Solid welded frame with welded A-Frame
- * Radius formed moldboard for efficient loading and unloading
- * High clearance scarifier bar for less trash build up
- * Hinged free floating rear cutting edge for smoother grading
- * HP Requirements: 30-90
- * Moldboard height 18"
- * Depth 21-1/2"
- * Two heat treated 1080 grade 1/2" x 6" reversible cutting edges
- * 3/8" thick end plates

MODEL	WIDTH	# SHANKS	LOAD CAPACITY	WEIGHT	LIST PRICE
TB260	5'	5	17.50 Cu. Ft.	586 lbs.	\$1799
TB272	6'	6	21.00 Cu. Ft.	661 lbs.	\$2399
TB284	7'	8	24.50 Cu. Ft.	841 lbs.	\$2999
TB296	8'	9	28.00 Cu. Ft.	904 lbs.	\$3149

BOX SCRAPERS

HYDRAULIC RETRACTABLE

TB30 Series



Tufline's TB30 series hydraulic retractable scarifier box blades are designed to break through tough ground and easily handle a variety of earth-moving jobs. The hydraulic scarifier bar makes adjustments from the operator's seat convenient. The scarifier bar is constructed of heavy duty welded mast and tubular reinforced steel for durability. The large capacity steel box has a dual sided hinged tailgate to allow for scraping, leveling, and back filling. The cutting edges are 1/2" x 6" steel and are reversible for extended life. The blade is 20" high and the end plates are 3/8" thick. 5' & 6' models are Cat. I – 3 Pt. hitch, 7' & 8' models are Cat. I/II – 3 Pt. hitch. Includes hydraulic cylinder & hose kit.

- * **Solid welded frame with welded A-Frame**
- * **Radius formed moldboard for efficient loading and unloading**
- * **High clearance hydraulically operated scarifier bar**
- * **Hinged free floating rear cutting edge for smoother grading**
- * **Two heat treated 1080 grade 1/2" x 6" reversible cutting edges**
- * **3/8" thick end plates**
- * **Hi-strength adjustable scarifier shanks**
- * **Designed for up to 80 HP**
- * **Moldboard height 20"**
- * **Box depth 22"**

MODEL	WIDTH	# SHANKS	LOAD CAPACITY	WEIGHT	LIST PRICE
TB3060H	5'	6	21.8 Cu. Ft.	725 lbs.	\$4149
TB3072H	6'	6	26.2 Cu. Ft.	815 lbs.	\$4499
TB3084H	7'	8	30.5 Cu. Ft.	1052 lbs.	\$4899
TB3096H	8'	8	34.9 Cu. Ft.	1146 lbs.	\$5159

BOX SCRAPERS

Hi-Capacity without Scarifiers



These box scrapers without scarifiers by **MONROE TUFLINE** are ideal for several applications. Use them for poultry houses, dairy barns and snow removal.

- * Solid welded frame with welded A-Frame
- * Radius formed moldboard for efficient loading and unloading
- * One heat treated 1080 grade 1/2" x 6" reversible cutting edges
- * Designed for up to 75 HP
- * Moldboard height 25"
- * Box depth 36"
- * Cat. 1 and 2, 3 Pt. hitch

MODEL	WIDTH	CAPACITY	WEIGHT	LIST PRICE
PHB84	7'	44 Cu. Ft.	684 lbs.	\$2369
PHB96	8'	50 Cu. Ft.	748 lbs.	\$2449

OPTIONS:

MODEL	DESCRIPTION	WEIGHT	LIST PRICE
SSPHB	Adjustable skid shoes (pair)	20 lbs.	\$175

Weights indicated are base machine weight, not shipping weight

BOX SCRAPER

CBS Series



The Monroe Tufline CBS Series corral box scraper takes the proven Tufline box scraper series to another level. These heavy duty implements are ideal for cleaning barn lots, poultry house, snow removal and general land leveling and grading. The CBS Series box scraper is constructed of 4" square tubing, 1/4" moldboard with 1/2" x 6" reversible cutting edge, and 3/8" endplates.

- * **Constructed of 4" Square Tubing**
- * **1/4" Thick Moldboard**
- * **3/8" Thick End Plates**
- * **Heat Treated 1080 Grade 1/2 X 6" Reversible Cutting Edge**
- * **27" High x 36" Inside Depth**
- * **Cat. I or II 3 Pt. hitch**

MODEL	DESCRIPTION	HP REQ'D	CAPACITY	WEIGHT	PRICE
CBS84	7' box scraper	35-80 HP	44 Cu. ft	725 lbs	\$2559
CBS96	8' box scraper	45-100 HP	50 Cu. ft	815 lbs	\$2949
CBS120	10' box scraper	55-120 HP	60 Cu. ft	1010 lbs	\$3199

BOX SCRAPER PULL TYPE



The Monroe Tufline pull type box scraper takes the proven Tufline box scraper series to another level. These heavy duty implements are ideal for cleaning barn lots, driveway grading, filling pot holes and general land leveling and grading. With tilting ability this is an excellent machine for crowning gravel roads or lanes, shaping slopes or cutting ditches.

- * **Constructed of 4" Square Tubing**
- * **1/4" Thick Moldboard**
- * **3/8" Thick End Plates**
- * **Heat Treated 1080 Grade 1/2 X 6" Reversible Cutting Edge**
- * **Includes Hydraulic Cylinders and Hoses**
- * **Tilting Ability**
- * **Clevis Hitch**
- * **9.5L x 15" Implement Tires**
- * **Includes Implement Tongue Jack**

MODEL	DESCRIPTION	HP REQ'D	CAPACITY	WEIGHT	PRICE
DS196T	8' box scraper	35-80 HP	44 Cu. ft	1300 lbs	\$7439
DS1120T	10' box scraper	45-100 HP	50 Cu. ft	1450 lbs	\$7679
DS1144T	12' box scraper	55-120 HP	60 Cu. ft	1600 lbs	\$8099

Weights indicated are base machine weight, not shipping weight

POWERED LANDSCAPE RAKES



Skid Steer Mount & 3 Pt. Hitch

WORKSAVER's new Powered Landscape Rakes, remove debris or sod to prepare a seedbed surface to create a new lawn or renovate an existing lawn. These powered landscape rakes also pulverize and set grade on new construction sites. Models available in 3', 4', 5' & 6' working widths to fit mini/compact skid steers. 6', 7' & 8' for standard skid steers. 5', 6', 7' & 8' for tractors with 3 Pt. hitch 540 RPM PTO. Rakes are available with your choice of 2" "SABRE TOOTH" rotors or 1-3/4" "CARBIDE TOOTH" rotors. Replaceable bearing housings and triple sealbearings provide durability and serviceability. Call your dealer for other models and sizes not listed.



PTC Model for 3 Pt. Hitch



PSS Model for Skid Steer



PXS Model for "Mini" Skid Steer

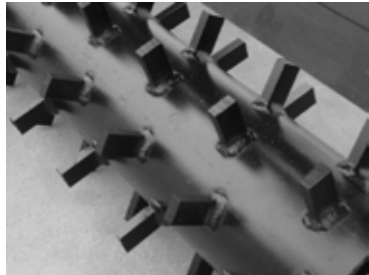

Sabre Tooth Rotor



Carbide Rotor

POWERED LANDSCAPE RAKES



Skid Steer Mount & 3 Pt. Hitch

- * Working widths up to 8 ft. available
- * Available with your choice of 2" "Sabre Tooth" or 1-3/4" "Carbide Tooth" rotors
- * Quick flip (self storing) side shields allowing ease of wind rowing rocks and debris
- * Flip up gauge wheels with pneumatic tires
- * #80 roller chain drive, H.D. models double #80 chain drive
- * Environmentally friendly dry chain case
- * Replaceable bearing housing with triple sealed bearings
- * Standard Manual Angle adjustment, optional hydraulic angle kits available
- * Adjustable material bar
- * 540 RPM PTO models come with slip clutch PTO, and Cat. I, 3 Pt. Hitch
- * Hydraulic models to fit skid steers come with hydraulic hoses with connect under pressure couplers

MODEL	DESCRIPTION	WEIGHT	LIST PRICE
PXS410	4 ft. with "Carbide Aggressor Tooth" rotor with universal "mini" skid steer mount	524 lbs	\$11,069
PXS410ST	4 ft. with "Sabre Tooth" rotor with universal "mini" skid steer mount	526 lbs.	\$10,299
PSS620	6 ft. with "Carbide Aggressor Tooth" rotor with universal "mini" skid steer mount, under 65 HP	830 lbs	\$12,469
PSS620ST	6 ft. with "Sabre Tooth" rotor with universal skid steer mount, under 65 HP	832 lbs.	\$11,639
PSHD865	8 ft. with "Carbide Aggressor Tooth" rotor with universal "mini" skid steer mount, over 65 HP	1144 lbs	\$16,179
PSHD865ST	8 ft. with "Sabre Tooth" rotor with universal skid steer mount, over 65 HP	1145 lbs.	\$15,299
PTC525	5 ft. with "Carbide Aggressor Tooth" rotor with 3 Pt. hitch CAT I for 24 - 40 HP	755 lbs	\$11,369
PTC525ST	5 ft. with "Sabre Tooth" rotor with 3 Pt. hitch CAT I for 24 - 40 HP	757 lbs.	\$10,559
PTC725	7 ft. with "Carbide Aggressor Tooth" rotor with 3 Pt. hitch CAT I for 24 - 40 HP	825 lbs.	\$13,079
PTC725ST	7 ft. with "Sabre Tooth" rotor with 3 Pt. hitch CAT I for 24 - 40 HP	827 lbs.	\$11,979

OPTIONS:

MODEL	DESCRIPTION	LIST PRICE
360640	Hydraulic angle kit for PXS models with 2 sets of remotes	\$1499
360779	Hydraulic angle kit with solenoid for PSS/PSHD models with one set of remotes	\$2149

CARTS POLY

Agri-Fab
Lawn Care Made Easy™

FIMCO
INDUSTRIES

These carts will perform a variety of tasks safely, reliably and efficiently. The clean ergonomic design and sturdy construction make these carts perfect for hauling yard refuse, firewood, topsoil, sand and gravel or any other job you need moved or carried. Available in steel or poly bed construction.

Model TC10P

List Price: \$269

- * 600 lb. weight capacity
- * Convertible push or tow dump cart
- * Fold behind tongue / drawbar assembly
- * One piece rustproof poly bed
- * Bed Size 30.5" W x 41" L x 11" H
- * Tire size 4.80" x 8" turf tire
- * Weight 67 lbs.



Model 450519

List Price \$465

- * 800 lb. / 17 cu.ft. Capacity Tow Cart
- * One Piece Poly Structural Foam Construction
- * 16 x 6.5 Knobby Tires with Grease Zerk in wheel hubs
- * Bed Size 38"W x 56"L x 14"H
- * 1" diameter heavy duty axle
- * Foot lever dumping mechanism
- * Weight 106 lbs.



[Click for Video](#)

Model 450528

Push Cart

List Price \$289

- * 200 lb. capacity
- * Large 20" flat free wheels
- * Sealed roller bearings
- * Bed Size 29"W x 22"L x 17"H
- * Weight 45 lbs.



[Click for Video](#)

Model 450529

List Price \$749

- * 1000 lb. / 17 cu.ft. load capacity
- * Needle bearings and grease zerks in wheels
- * Tube frame allows better ground clearance
- * 18" x 9.5" all terrain pneumatic tires
- * Bed Size 38"W x 56"L x 14"H
- * Weight 100 lbs.



See additional carts on following pages

CARTS STEEL

Agri-Fab
Lawn Care Made Easy

FIMCO
INDUSTRIES

Model TC1018

List Price: \$289

- * 750 lbs. load capacity
- * Bed size 18 ga. 31"W x 42"L x 13"H
- * Tire size 16" x 4.8" x 8" pneumatic turf tires
- * Solid 3/4" dia. axle
- * Removeable tailgate
- * Easy single lever dump release
- * Weight 99 lbs.



Model TC17

List Price: \$489

- * 1500 lbs. load capacity
- * Bed size 16 ga. 37"W x 59"L x 16"H
- * Tire size 16" x 6.5" pneumatic turf tires
- * Removable tailgate
- * Easy single lever dump release
- * Weight 171 lbs.



Model TC174

List Price: \$719

- * 2000 lbs. load capacity
- * 4 wheel, front steerable axle
- * Bed size 16 ga. 37"W x 59"L x 16"H
- * Bed design: one piece
- * Tire size 16" x 6.5" - 8" pneumatic turf tires
- * Removable tailgate
- * Solid 3/4" steel axle
- * Weight 224 lbs.



Model 450350

List Price: \$1149

- * 1000 lbs. load capacity
- * Tandem axle with 4 - 18 x 9.50 all terrain tires
- * Bed size 16 ga. 32.5"W x 61"L x 12"H
- * Needle bearing wheels
- * 1" diameter steel axles
- * Includes steel tube rail kit
- * Weight 230 lbs.



TRAILERS



TRM16

[Click for Video](#)



TRM160HD

Multiva is a perfect trailer for a user who values effectiveness, practicality and durability in transport. Strong frame construction, sturdy bogey and a robust body prevent the trailer from twisting during tipping. Low height, together with a wide track, makes the trailer even more stable. Wear resistant and special steel guarantee the best durability and longest lifetime. Hardox-wear resistant steels and Strenx-special steels have strength of their own class in comparison to regular (Fe52) steel.

- * Tubular bar frame
- * Standard duty trailer body floors use 5mm Strenx steel, equivalent to 10 mm Fe52 steel
- * HD trailer body floors use 6mm Hardox steel, equivalent to 18mm Fe52 steel
- * Retractable, hydraulic tailgate

MODEL	CAPACITY	VOLUME	WEIGHT	LIST PRICE
TRM16	16MT	9.2 cubic meters	6945 lbs.	\$35,569
TRM160HD	16MT	9.9 cubic meters	8488 lbs.	\$45,498

TINE DE-THATCHERS

Pull Type

Agri-Fab
Lawn Care Made Easy™



[Click for Video](#)



De-thatching is very important in environmentally conscious lawn care. These de-thatchers by **AGRI-FAB** do a gentle job of bringing matted layers of thatch and large clippings to the surface for a healthy lawn.

- * Twenty 3/16" heated tines on 40"
- * Twenty four tines on 48"
- * 40" and 48" working width available
- * 7" x 1.5" semi-pneumatic tires

MODEL	WIDTH	WEIGHT	LIST PRICE
4502941	40"	33 lbs.	\$129
4502951	48"	37 lbs.	\$185

Weights indicated are base machine weight, not shipping weight

LAWN SWEEPERS

Push Type



The **AGRI-FAB** Push Lawn Sweeper makes cleaning up smaller yard spaces a breeze. Made with sturdy lasting parts, this sweeper will last season after season. It's lightweight so you can do the clean up job quickly and better than a rake. It folds up to fit in your garage.

- * 26" sweeping width
- * 6.2 cu. ft. hopper
- * 9.75"x 2.25" wheels

MODEL	DESCRIPTION	WEIGHT	LIST PRICE
450218	26" Push type lawn sweeper	25 lbs.	\$225

LAWN SWEEPER

Agri-Fab
Lawn Care Made Easy



450352

[Click for Video](#)



450522

Make a clean sweep of leaves, grass, lawn debris and more with an AGRI-FAB lawn sweeper. These models make quick work of just about any pickup task and do a thorough job the first time around. Unique design makes dumping of debris easy too. Optional front mount de-thatching unit available.

450352

- * 6 – 12” diameter brushes
- * 11 x 2-1/2” wide wheels
- * 17 cu. ft. hopper capacity
- * 42” sweep width
- * Empty hopper from tractor seat
- * Adjustable brush height
- * Universal hitch easily & quickly adjusts to any tractor

450522

- * 6 – 12” diameter brushes
- * Flow thru hopper bag
- * 27 cu. ft. hopper capacity
- * 52” sweep width
- * 12” x 2.5” tire/wheels with ball bearings
- * Single center lever with preset height for brush height adjustment
- * Universal hitch easily & quickly adjusts to any tractor

MODEL	DESCRIPTION	WEIGHT	LIST PRICE
450352	42” Lawn Sweeper	94 lbs.	\$399
450522	52” Lawn Sweeper	90 lbs.	\$599

OPTIONS:

MODEL	DESCRIPTION	WEIGHT	LIST PRICE
4503433	Front mount de-thatcher fits above lawn sweepers	23 lbs.	\$119

LAWN SWEEPER SMARTSWEEP

Agri-Fab
Lawn Care Made Easy



[Click for Video](#)

The NEW SmartSWEEP from Agri-Fab is designed to make sweeping up yard debris easier than ever. This unit doesn't skip, solving the #1 consumer frustration with current lawn sweepers. 25 cu. ft. hopper capacity. Exclusive patent pending offset hitch design allows users to simultaneously cut and sweep lawn clippings or leaves. Exclusive, patent pending ergonomic dumping mechanism, no more rope to pull. One button brush height adjustment, adjusts just the brush, not the whole unit.

- * 44" sweeping width
- * 25 cu.ft. hopper capacity
- * #4 - 12" diameter brushes
- * Offsetable hitch
- * Ergonomic dumping mechanism
- * One button brush height adjustment
- * Design allows sweeper to collapse for compact storage

MODEL	DESCRIPTION	WEIGHT	PRICE
450492	44" SmartSWEEP	94 lbs.	\$555

OPTIONS:

MODEL	DESCRIPTION	WEIGHT	LIST PRICE
4503433	Front mount tine de-thatcher fits above "TOW TYPE" sweepers	23 lbs.	\$119

LAWN VACS

Agri-Fab
Lawn Care Made Easy™



450540

[Click for Video](#)



55188

For any size yard, Agri-Fab's **Mow-N-Vac** or **Chip-N-Vac** offer proven performance. 80 MPH worth of suction provides enough power to collect large quantities of grass, leaves, twigs, pine needles, etc. that can be dumped effectively with any of Agri-Fab's vac systems. All units include a safety engine shut-off which prevents accidental engine start-ups, a universal fit mower deck adapter. Units fit only right hand discharge mid-mount mowers. Optional 65640 hose kit is required for front mount zero turn mowers.

MODEL	DESCRIPTION	WEIGHT	LIST PRICE
55188	Hard Top Mow-N-Vac with 208cc B & S engine with 2 year warranty. Large 26 bushel/32 cu.ft. capacity Includes cart with durable vented hard top design.	340 lbs.	\$2189
450540	Hard Top Chip-N-Vac with 208cc B & S engine with 2 year warranty. Large 26 bushel/32 cu.ft. capacity, chips up to 2" Dia. brush. Includes cart with durable vented hard top design	384 lbs.	\$2649

OPTIONS:

MODEL	DESCRIPTION	WEIGHT	LIST PRICE
450253	5" x 12' long, remote hose kit for vacuuming flower beds and from under trees	19 lbs.	\$245
65640	Hose extension kit with adapter for zero turn. Front mount mower deck		\$119

Weights indicated are base machine weight, not shipping weight

SMARTLINK ATTACHMENTS

Agri-Fab
Lawn Care Made Easy™



450474
Core/Plugger Aerator



450458



450473
Master Platform



450457

[Click for Video](#)

The SmartLINK system from Agri-Fab allows users to switch from one lawn implement to another in seconds, without tools. Purchase the “master platform” and then any of the three different attachments: 40” TURF SHARK™ Curved Blade Aerator, 40” Core/Plugger Aerator, or the 40” Tine Dethatcher, as required, or purchase all four pieces. Dethatch, spike or aerate your lawn with the pull type master platform that can be easily hooked to any lawn tractor. SmartLINK lawn care system provides unprecedented versatility, and can be easily stored.

- * Master platform provides durable heavy gauge steel deck and drawbar
- * Universal hitch fits any lawn tractor
- * Rustproof aerator/core knives allows air, water and nutrients to reach into the soil
- * Patented Turf Shark™ spike aerator designed for thorough soil penetration without messy soil plugs
- * Tine dethatcher effectively loosens and lifts thatch for healthier lawn growth
- * Flat free tires 9-1/2" diameter x 2-1/2" wide

MODEL	DESCRIPTION	WEIGHT	LIST PRICE
450453Q	Master Platform with ALL 3 Attachments	158 lbs.	\$579
450473	Master Platform	60 lbs.	\$215
450474	40" Core/Plugger Aerator	29 lbs.	\$135
450458	40" Turf Shark™ Curved Blade Spike Aerator	23 lbs.	\$125
450457	40" Tine Dethatcher	19 lbs.	\$115

AERATORS

Pull Type

Agri-Fab
Lawn Care Made Easy

[Click for Video](#)



450299



450525

Core aerating is increasingly important in aesthetically and environmentally conscious lawn care. These core aerators by **AGRI-FAB** are perfect for highly compacted clay soil conditions allowing seed, fertilizer, air and water to reach deep into the lawns roots.

450525

- * 40" spike aerator
- * 10 spike discs
- * Hitch pivots under tray for easy storage
- * 100 lbs. capacity weight tray

450299

- * 48" core/plug aerator
- * 3" aeration depth
- * 32 galvanized plug aerator knives
- * Tray weight capacity 140 lbs.
- * Single hand lift lever
- * Flat free tires

MODEL	DESCRIPTION	WEIGHT	LIST PRICE
450525	40" spike aerator	44 lbs.	\$199
450299	48" plug aerator	90 lbs.	\$339

LAWN ROLLERS



450216 Shown (Steel)



450267



LRP2448B Shown (Poly)



LR3632



Uneven ground from frost heaving, newly sewn lawns or sod that just needs to be packed down, are ideal jobs for these lawn rollers. These steel or poly tow rollers can be used for light or heavy duty performance. LR3632 lawn roller is made from recycled propane tanks and uses 1/4" thick material.

MODEL	ROLLER DRUM	WEIGHT W/WATER	SHIPPING WEIGHT	LIST PRICE
450267	POLY 18" dia. x 24" wide Push / Tow	250 lbs.	40 lbs.	\$189
LRP2448B	POLY 24" dia. x 48" wide	825 lbs.	82 lbs.	\$419
450179	STEEL 24" dia. x 36" wide	640 lbs.	110 lbs.	\$339
450216	STEEL 24" dia. x 48" wide	910 lbs.	170 lbs.	\$429
LR3632	STEEL 32" dia. x 36" wide	1350 lbs.	350 lbs.	\$519

SPREADERS

Broadcast - Push Type



450526



450388

[Click for Video](#)

Broadcast spreaders spread everything from fertilizer, seed, ice melters and more. Solid construction and reliable design ensures even and continuous flow and spread of materials, eliminating streaks. Hoppers constructed of weather resistant polyethylene.

MODEL	DESCRIPTION	WEIGHT	LIST PRICE
450388	85 lb. Capacity 10" x 4" pneumatic tires. Up to 10' Spread width	20 lbs.	\$109
450526	110 lb. Capacity Poly hopper new design 10" x 4" pneumatic tires. 8' to 10' spread width	27 lbs.	\$229

OPTIONS:

MODEL	DESCRIPTION	LIST PRICE
40883	Hopper cover for 450388	\$15
69128	Spreader grate for 450388	\$19
41316	Hopper cover for 450526	\$15
68871	Deflector for ice melter for 450526	\$26
69411	Spreader grate for 450526	\$20

SPREADERS

Broadcast - Tow Type

Agri-Fab
Lawn Care Made Easy



450527

[Click for Video](#)



450530

[Click for Video](#)

Broadcast spreaders spread everything from fertilizer, seed, ice melters and more. Solid construction and reliable design ensures even and continuous flow and spread of materials, eliminating streaks. Hoppers constructed of weather resistant polyethylene. On/Off Control is accessible from tractor seat

MODEL	DESCRIPTION	WEIGHT	LIST PRICE
450530	85 lbs. Cap 10" x 4" pneumatic tires Up to 10' Spread Width	20 lbs.	\$115
450527	110 lbs. Cap. 10" x 4" pneumatic tires Poly hopper new design 8' to 10' spread width	27 lbs.	\$219

OPTIONS:

MODEL	DESCRIPTION	LIST PRICE
40883	Hopper cover for 450530	\$15
69115	Deflector for ice melter for 450530	\$24
69128	Spreader grate for 450530	\$19
41316	Hopper cover for 450527	\$15
68871	Deflector for ice melter for 450527	\$26
69411	Spreader grate for 450527	\$20

SPREADERS

SmartSPREADER



450463

[Click for Video](#)



450462

- * 130 lb. capacity
- * Unique, user friendly spreader-setting knob for precise fertilizer application
- * Spring loaded ON/OFF lever

MODEL	DESCRIPTION	WEIGHT	LIST PRICE
450462	SmartSPREADER Push	37 lbs.	\$295
450463	SmartSPREADER Tow	37 lbs.	\$295

OPTIONS:

MODEL	DESCRIPTION	LIST PRICE
41316	Hopper cover for both models	\$15
68871	Deflector for ice melter for both models	\$26
67663	Metal spreader grate for both models	\$59
69411	Plastic spreader grate for both models	\$20

Weights indicated are base machine weight, not shipping weight

SPREADER

Broadcast

Pull-Type

Agri-Fab
Lawn Care Made Easy



[Click for Video](#)

Agri-Fab broadcast spreaders spread everything from fertilizer, seed, ice melter and more. Solid construction and reliable design ensures even and continuous flow and spread of materials eliminating streaking. Hopper construction of weather resistant polyethylene. On/Off control is accessible from garden tractor seat.

- * 175 lb. Capacity
- * Spread width up to 12 ft. depending on material being spread
- * Large 15" x 6" pneumatic turf tires with ball bearing hubs
- * Poly hopper and spread plate
- * Enclosed gear box
- * Heavy duty steel gears
- * Includes hopper cover

MODEL	DESCRIPTION	WEIGHT	LIST PRICE
450329	175 lb. capacity, tow type Fertilizer Spreader	57 lbs.	\$415

OPTIONS:

MODEL	DESCRIPTION	LIST PRICE
41316	Hopper cover	\$15

DROP FERTILIZER SPREADER

Agri-Fab
Lawn Care Made Easy



450288

The Agri-Fab drop spreader is the proper tool for overseeding, weed control, fertilizing and more. You can count on the Agri-Fab spreader to help. Designed for easy operation and even coverage, our spreaders will give you great results time after time.

- * 175 lbs. capacity
- * 42" spread width
- * 3/4" axle
- * Covers approx. 40,000 sq. ft.
- * Premium galvanized steel agitator.
- * Spreader settings for a multiple of materials.
- * Ground Drive

MODEL	DESCRIPTION	WEIGHT	LIST PRICE
450288	Drop fertilizer spreader 14" x 4" pneumatic tires	45 lbs.	\$345

SPREADERS

ATV, UTV or TRUCK MOUNT



[Click for Video](#)



The SWISHER COMMERCIAL PRO spreaders are available in a ATV mount or truck mount. Both units are universal fit, with a heavy duty double ball bearing, permanent magnet DC 12 volt motor. Control the flow rate with operator accessible adjustable feed gate. All control plates are zinc plated for corrosion protection. Adjustable spread width 4' to 16' depending on material to be spread. Spreads grass seed , fertilizer & ice melt.

ATV Model

- * Universal fit
- * On and off switch is frame mounted
- * 12 volt motor
- * 8" easy fill spin-on cap with breather
- * Opaque 15 gallon (2 cu. ft.) poly tank
- * 150 lb. capacity

UTV-TRUCK Model

- * Universal fit
- * Mounts to existing 2" x 2" receiver
- * 12 volt motor
- * 8" easy fill spin-on cap with breather
- * Opaque 25 gallon (3.3 cu.ft.) poly tank
- * 300 lb. capacity

MODEL	DESCRIPTION	WEIGHT	PRICE
19920	ATV Mount Spreader 150 lb. capacity	45 lbs.	\$599
20110	UTV-Truck Mount Spreader 300 lb. capacity	70 lbs.	\$729

SPREADERS

Broadcast 12 Volt



The FIMCO 12 Volt broadcast spreaders are available in an ATV mount or Tow/ Pull type. The ATV mount can utilize the optional 2" Truck hitch receiver to mount onto a pickup truck or SUV. The spreader has 2.2 cu.ft. (1.5 bu.) poly hopper which has a capacity of up to 145 lbs. depending on type of material. Stainless steel radial 6 blade fan/spinner can spread material up to 45 feet (depending on type of material to be spread). Can be used with fertilizer, seed, powders, granular, insecticides, fungicides, herbicides and ice melter.

- * 2.2 cu.ft. (1.5 bu.) (16 gal.) rust proof poly hopper
- * Up to 145 lb. capacity
- * 5 ft. to 45 ft. variable spread width
- * Stainless steel radial 6 blade fan / spinner
- * 12 volt motor with variable speed control with On-Off switch
- * Universal ATV Mounting, 2" receiver hitch mounting available with purchase of optional 5301901
- * Pull/Tow type comes with 15/600 x 6 tires

MODEL	DESCRIPTION	WEIGHT	LIST PRICE
ATVDMS12V	ATV mounted spreader	56 lbs.	\$659
DMSTR12V22	ATV pull type spreader	59 lbs.	\$679

OPTIONS:

MODEL	DESCRIPTION	LIST PRICE
5058193	Clear hopper cover	\$10
5301901	2" receiver hitch for ATVDMS12V	\$169

SPREADER

3 Pt. Hitch, 12 volt



The FIMCO 3 Pt. hitch spreader features a tough, corrosion - resistant 5.0 cu.ft. / 200 lb. capacity poly hopper with a stainless steel radial six blade spreading fan. Adjustable slide gate allows you to control the amount of material you're spreading, and can be opened or closed with a simple turn of the on/off handle. The FIMCO spreader uses a variable-speed 12 volt motor (with on/off switch) that lets you change the spread width from 5 ft. to 45 ft. (depending on material being spread).

- * Poly Hopper
- * 5.0 Cu.ft. / 200 lb. capacity
- * CAT I, 3 Pt hitch
- * Stainless steel radial six blade spreader fan
- * 12 volt motor
- * Variable speed controller
- * Wiring harness to power supply

MODEL	DESCRIPTION	WEIGHT	LIST PRICE
DMS3PT12V50	Spreader 200 lb. capacity 12 volt	125 lbs.	\$779

SPIKER SEEDER DROP SPREADER



The AGRI-FAB Tow Behind Spiker/Seeder/Drop Spreader is a versatile implement for spreading seed, fertilizer, or for over seeding lawns. This unit can be attached to any lawn and garden tractor or ATV.

- * Tow Type
- * 175 lb.(80 L) capacity
- * Approximate coverage 40,000 sq. ft. (approximately 1 acre)
- * Spread Width 42"
- * Poly Hopper
- * Galvanized steel agitator
- * Steel spike wheels
- * Flat free tires
- * On-Off control accessible from garden tractor seat

MODEL	DESCRIPTION	WEIGHT	LIST PRICE
450301	Spiker/Seeder/Drop Spreader	83 lbs.	\$549

MIXER - HYDRAULIC Skid Steer Mount



The **WORKSAVER** skid steer mixer has direct hydraulic drive of the gearbox which eliminates chain and sprocket maintenance and is ideal for all mixing applications and allows operator to mix, transport and place the concrete in the right location more efficiently. This unit has 5 Cu. Ft. capacity (1 bag mix) capacity of concrete.

SKID STEER MOUNT

- * Fits "Universal Style" skid-steer attachment system
- * Hydraulically driven gear box
- * Minimum hydraulic flow required 8 GPM
- * Gear ratio 3.18 : 1
- * All welded steel drum construction with internal paddles for uniform mixing and clean dumping
- * Includes flow control valve (On-Off) for easy operation
- * Hydraulic hoses included with connect under pressure flat faced couplers

MODEL	DESCRIPTION	WEIGHT	LIST PRICE
SS590	Skid steer hydraulic	395 lbs.	\$5649

MEGA MIXER



[Click for Video](#)

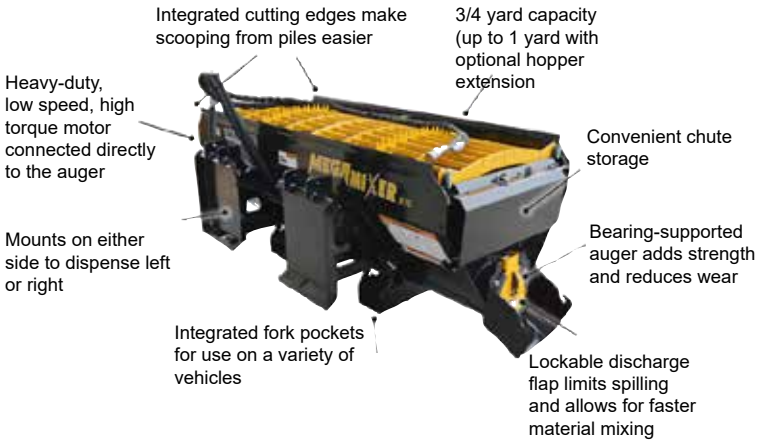

Eliminate backbreaking labor with the Danuser Mega Mixer! From concrete to livestock feed, mix, scoop, and dispense a wide variety of materials with ease. With adjustable mounting brackets and pallet fork tine slots on both sides, conveniently dispense left or right. Built-in cutting edges and a robust design make it well-suited for scooping from piles. Comes standard with dual safety grates, including integrated bag busters, that can be opened individually from either side.

- * Includes two 2' multi-link chutes
- * 3/4 yard capacity (up to 1 yard with optional hopper extension)
- * Bearing supported auger
- * Heavy duty, low speed, high torque motor connected directly to auger
- * Integrated cutting edges make scooping from piles easier
- * Supports up to 25GPM, 3500 PSI hydraulics

MODEL	DESCRIPTION	WEIGHT	LIST PRICE
DU170001	Mixer with all steel auger	898 lbs.	\$7299

OPTIONS:

MODEL	DESCRIPTION	WEIGHT	LIST PRICE
DU170095	Hopper extension	121 lbs.	\$689
DU170100	24" Chute (can be linked)	15 lbs.	\$69
DU170103	36" Chute (can be linked)	22 lbs.	\$85

Weights indicated are base machine weight, not shipping weight

SPREADERS GROUND DRIVEN



This fertilizer spreader, is manufactured to high standards and will hold up to the rigors of your everyday needs. Adjustable tow bar allows the spreader to be used on multiple hitch heights. High flotation tires on a wide base gives greater stability over many types of terrain. Works for fertilizer, seed, and ice melter spreading applications.

- * Heavy Duty Steel Gears in sealed gearbox
- * Adjustable Towing Hitch
- * High flotation Tires 13 x 5.00 – 6
- * Powder coated painted frame and hopper
- * One piece steel hopper
- * Left – Centre – Right Spread Pattern
- * Poly Spreading Disc
- * Optional Spread Deflector Shield Available
- * 225 lb / 105 litre hopper capacity

MODEL	HOPPER CAPACITY	SPREADER WIDTH	HOPPER HEIGHT	WEIGHT	LIST PRICE
PTS100	225 lbs	20 ft	40"	60 lbs	\$750

OPTIONS:

MODEL	DESCRIPTION	LIST PRICE
PTS001	Deflector Shield, reduces spread width	\$95
PTS002	Hydraulic gate opener	\$379

SPREADERS

Baby-Hop

Ground Driven



Easy connecting pull type hitch, ground controlled distribution, and rugged construction makes the **BEFCO** Baby-Hop spreader the perfect companion for your ATV, riding mower or small garden tractor. Ideally suited for even distribution of fertilizer, seed, salt and dry sand. Baby-Hop spreaders come complete with:

- * One piece seamless painted steel hopper
- * Even spread left-center-right pattern
- * High flotation air tires
- * 103-130: 13x5.00-6
- * 106-130: 16x6.50-8
- * Easy connecting pull type hitch
- * Sturdy tubular frame
- * Hopper levelling adjustment
- * Sealed heavy duty gearbox

MODEL	HOPPER CAPACITY CU.FT/LBS	SWATH SPREAD	WEIGHT	LIST PRICE
103-130	3.5 / 226	20'	64 lbs.	\$1039
106-130	5.6 / 362	20'	84 lbs.	\$1379

NOTE: Poundage capacity calculated at 13-13-13 fertilizer weight of 64 lbs./Cu. Ft.

OPTIONS:

MODEL	DESCRIPTION	LIST PRICE
AA1-120	Deflector shield-reduces spreading width to approximately 4'	\$145

Weights indicated are base machine weight, not shipping weight

SPREADERS

Spin Type

Steel



These quality spreaders are designed for tractors from 16 to 30 HP, 540 PTO RPM, Category 1, 3 Pt. hitch. Ideal for distribution of fertilizer, seed, salt, dry sand and much more. Spreaders come complete with:

- * **HP Requirements: 16-30, 540 RPM**
- * **One piece seamless painted steel hopper**
- * **Three different spread patterns**
- * **Heavy duty shielded PTO shaft (1-3/8" ASAE Cat. 1)**
- * **Sturdy tubular frame**
- * **Selective double gate opening**
- * **Sealed heavy duty gearbox**
- * **Fixed agitator**
- * **Cat. 1, 3 Pt Hitch on all models**

OPTIONS	HOPPER CAPACITY		
MODEL	CU.FT/LBS	WEIGHT	LIST PRICE
203-120	3.5 / 226	81 lbs.	\$999
206-121	4.8 / 311	102 lbs.	\$1059
209-121	10.6 / 678	125 lbs.	\$1099
212-121	17.6 / 1130	136 lbs.	\$1169

NOTE: Poundage capacity calculated at 13-13-13 fertilizer weight of 64 lbs./Cu. Ft.

OPTIONS:

MODEL	DESCRIPTION	LIST PRICE
009-9524	Deflector shield fits model 203 & 206	\$139
009-9979	Tumbling style agitator 203 model only	\$119
009-9638	Deflector shield fits model 209 & 212	\$269
009-9978	Tumbling style agitator for 206, 209 and 212	\$119
009-9458	Siderow discharge for model 209 & 212 only	\$599

SPREADERS

SPIN TYPE - POLY HOPPER



BRI poly hopper spreaders are available in two models, Cat.I 3 Pt hitch, 540 RPM PTO. Bottom opening gates ensure a constant and accurate flow of material to spinner. Variable positioning gate openings and fin adjustments allow material to drop on different positions of the spinning disc, therefore giving a left-right-center spread pattern.

- * Durable no-rust Poly Hopper
- * Cat. I 3 Pt. Hitch
- * 540 RPM PTO
- * Simple adjustable left-right-center spread pattern
- * Galvanized spin disc with multi-positioning adjustable fins
- * Maximum spread pattern 49 feet depending on material being spread

MODEL	DESCRIPTION	WEIGHT	LIST PRICE
SSP250	575 lb. / 196 Litres	123 lbs.	\$895
SSP400	860 lb. / 293 Litres	130 lbs.	\$965

SPREADERS

Turbo Hop 3 Pt.



301-300 Shown

[Click for Video](#)



303-600 Shown

Turbo Hop spreaders are designed for tractors from 20 to 60 HP, 540 PTO RPM, with a maximum spread swath of 40'-46'. Ideal for distribution of fertilizer, seed, salt, dry sand where accuracy and precision in application is needed. Turbo Hop spreaders come complete with:

- * HP Requirements: 20-60, 540 RPM
- * Polyethylene hopper
- * Spreader spouts made of nylon and reinforced fiberglass
- * Stainless steel opening control disc
- * Cast steel anti-wear agitator
- * Heavy duty shielded PTO shaft (1-3/8" ASAE Cat. 1)
- * Sturdy tubular frame
- * Micrometric flow control adjustment
- * Heavy duty cast steel gearbox in oil bath
- * 301-300-400 cone type hopper Cat. I / II 3Pt. hitch
- * 303-600-999 retangular type hopper Cat. I / II 3Pt. hitch

MODEL	HOPPER CAPACITY		SPREAD		
	CU.FT/LBS		WIDTH	WEIGHT	LIST PRICE
301-300	9.00 / 576		17' - 47'	256 lbs.	\$3999
301-400	12.80 / 820		17' - 47'	267 lbs.	\$4349
303-600	20.6 / 1318		17' - 47'	419 lbs.	\$5299
303-999	36.1 / 2310		17' - 47'	455 lbs.	\$6349

NOTE: Poundage capacity calculated @ 13-13-13 fertilizer weight of 64 lbs. per cubic foot

Filter grates, agitator extensions and hydraulic controls available.

ZA-M FERTILIZER SPREADERS



[Click for Video](#)



- * Important Parts in Stainless Steel
- * Square Shallow Twin Tip Hopper
- * Indestructible Oil Bath Gearboxes
- * Requires pair OM spreading disc, see options.
- * Stainless Steel Guard Tube to Protect Spreading Discs
- * Spiral Agitators Ensure a Very Even Fertilizer Flow
- * Hydraulic Single Shutter Slide Control for the Right or Left Hand Side
- * Standard with Traffic Lights and Warning Plates
- * Filling Sieve against Foreign Particles
- * 540 RPM PTO Shaft
- * CAT II 3 Pt. Hitch
- * Maximum Payload up to 6835 lbs. (3100kg)
- * Calibration Device for the Simple Check of the Pre-Adjusted Spread Rate
- * Comprehensive Setting Charts for all Types of Fertilizer
- * Calculation Disc Rule to Determine the Required Shutter Slide Position
- * Optional Spreading Disc, Hopper Extensions, Hopper Covers, Border Spreading Devices available

MODEL	DESCRIPTION	WEIGHT (LBS.)	LIST PRICE
ZAM1501	1500 L / 395 gal capacity Requires OmniaSet (pair) spreading disc see options on NEXT PAGE.	337 kg	\$9449

ZA-M FERTILIZER SPREADERS



MANDATORY OPTION SPREADING DISCS:

Choose one set below, required to make machine complete

OmniaSet Spreading discs (pair) are equipped with pivoting spreading vanes that generate a spread pattern that is extremely precise and safe. Discs are made from stainless steel and are easy to interchange.

Spreading width in meters depending on material being spread.

MODEL	DESCRIPTION	WEIGHT	LIST PRICE
927870	Pair (2) spreading disc OmniaSet OM10-12m	15 lbs.	\$589
927776	Pair (2) spreading disc OmniaSet OM10-16m	18 lbs.	\$605
927777	Pair (2) spreading disc OmniaSet OM18-24m	27 lbs.	\$675
927778	Pair (2) spreading disc OmniaSet OM24-36m	33 lbs.	\$1399

OTHER AVAILABLE OPTIONS:

MODEL	DESCRIPTION	WEIGHT	LIST PRICE
S500	922782 500 L / 130 gallon hopper extension	27 kg	\$659
L1000	935040 1000 L / 265 gallon hopper extension	57 kg	\$1459
927784	Hopper cover for spreaders without extensions or with S500 hopper extensions only	26 kg	\$999
927785	Hopper cover for spreaders with L1000 extensions	29 kg	\$1099
1733010	Boundary spread deflector Left Hand Side	5 kg	\$219
948320	Rolling parking stand	24 kg	\$609
935334	Limitier "ML" boundary spreader attachment L.H.	24 kg	\$1729
935335	Limitier "ML" boundary spreader attachment R.H.	24 kg	\$1729
922911	Calibration device for spread rate check	2 kg	\$205
125900	Mobile fertilizer test kit	20 kg	\$579

ZA-M FERTILIZER SPREADERS



[Click for Video](#)

SBS – Soft Ballistic System

Mineral fertilizer needs to be gently handled to ensure a precise distribution and an exact placement to the plant over the entire working width. Fertilizer, which has been damaged while going through the spreader, will not be precisely distributed. The AMAZONE Soft Ballistic System is integrated into all ZA-M mounted spreaders where the agitator, metering components and spreading discs are all optimally matched to protect the fertilizer and ensure even distribution over the entire working width.

Stainless Steel Spreading System

The entire spreading system of the ZA-M spreaders is made from stainless steel: Hopper tips and agitator spirals. Entire base plates with setting rate slides and hydraulic shutters. Spreading discs with the spreading vanes Fully enclosed deflector plates

Oil Bath Gearboxes

The oil bath gearboxes have proven to be the indestructible heart of the AMAZONE twin disc centrifugal spreader. Repetitive test procedures are conducted. They are maintenance free and provide integrated overload safety to prevent gearbox damage. Rate Adjustment: Simple – Reliable – Precise The spreading rate and the working width are preselected from the extremely comprehensive setting chart. Clear easy to read scales help you to set the spreading rate exactly using the shutter slide.

The Double Shutter Control System

The rate shutters and on-off shutters can be operated independently of each other. The double acting hydraulic slides ensure an instantaneous opening and closing of the shutters at ends of the field.

OM Omnia-Set Spreading Discs

The OM Omnia-Set spreading discs are equipped with pivoting spreading vanes that generate a spread pattern that is extremely precise and safe. With the aid of an easily readable scale that is in the users field of view, the spreading vanes can be adjusted easily and exactly without tools. AMAZONE provides comprehensive setting charts for all kinds of fertilizer and seed. The OM Omnia-Set spreading discs are made from stainless steel and are easily installed.

Today's farmer and agricultural custom operators need fertilizer spreaders where, safety, accuracy and dependability come first. AMAZONE is safe in every respect: on the road, in the field, during adjustment and while spreading. It is not just about saving money, but also protecting the environment and ensuring safety on the road as well as accuracy in the field with accurate spreading of your fertilizer.

UTILITY VEHICLE SPRAYER



- * Heavy duty blow molded 65 gallon polyethylene tank
- * Low profile for improved stability / center of gravity
- * Molded handles for easy installation in UTV's
- * Conveniently positioned pump / manifold to be accessed from UTV cab to easily set sprayer PSI
- * 12 volt diaphragm pump, 3.8 gpm, 45 PSI maximum
- * New Multi-Lid included
- * Holds 625 lbs. full of water
- * Quick release spray boom for fast assembly & disassembly from sprayer
- * Can be used with tailgate of UTV closed or open
- * 7 nozzle 3 section folding boom
- * 140" spray pattern coverage
- * Roundup ready
- * Deluxe pistol type hand gun with 25ft of hose

MODEL	DESCRIPTION	WEIGHT	LIST PRICE
UTV657 (5302830)	65 gal. utility sprayer 7 nozzle, 3 section folding boom 12 volt, 3.8 GPM pump.	100 lbs.	\$1389

SPOT & ATV SPRAYER



[Click for Video](#)



ATV25700QR

15 Gal. Spot Sprayer

- * 15 Gal. (U.S.) corrosion resistant polyethylene tank
- * Full drain out capabilities with molded in drain port, cap & tether
- * Large sump pickup
- * 5" fill lid with tether
- * 12 volt (demand) diaphragm 1.0 GPM 35 PSI pump
- * 18" lever handgun with adjustable nozzle with 15 ft. of hose
- * Max. horizontal throw 25 ft.
- * Max. vertical throw 12 ft.

25 Gal. ATV Sprayer with Boom

- * 25 Gal. (U.S.) corrosion resistant polyethylene tank
- * Universal ATV mounting brackets
- * Full drain out capabilities with molded-in drain port, cap & tether.
- * 12 volt diaphragm demand style pump, 2.1 GPM. Pressure range 0 – 60 PSI
- * Adjustable Pressure
- * Pressure Gauge
- * 18" Handgun with adjustable nozzle & 15 ft. of hose
- * 7 Nozzle, 3 section folding boom 140" spray coverage Includes nozzles and screens
- * NEW QUICK RELEASE boom

MODEL	DESCRIPTION	WEIGHT	LIST PRICE
LG15EC	15 gal. spot sprayer with hand gun & 15 ft. hose	18 lbs.	\$179
ATV25700QR	25 gal. ATV sprayer with 7 nozzle 3 section boom (140") with hand gun & 15 ft. hose	66 lbs.	\$659

OPTIONS:

MODEL	DESCRIPTION	LIST PRICE
7772014	Multi lid measuring device	\$35

Weights indicated are base machine weight, not shipping weight

ESTATE SPRAYERS

Tow Type



ATVTS6012V



TR40EX



LG30TRL

[Click for Video](#)

- * Measured in U.S. gallon / litres
- * Corrosion resistant polyethylene tanks
- * Lower tank profile for improved stability
- * Full drain out capability with molded in drain port, cap & tether
- * Full length drain sump
- * Large pickup sump
- * 5" fill lid with tether
- * Both gallon (US) and litre fluid volume indicator
- * 30 gallon includes lever handgun with adjustable nozzle and 15ft of hose
- * 40 & 60 gal. includes deluxe pistol grip handgun with adjustable nozzle and 25ft of hose
- * 30 & 40 gallon: 12 volt 2.1 gpm, 60 psi diaphragm pump
- * 60 gal. 12 volt 3.8 gpm, 45 psi diaphragm pump
- * "On-Off" Switch
- * Includes spray boom (includes nozzles and screens):
 - 30 gallon, 2 nozzle 80" coverage
 - 40 gallon, 5 nozzle 100" coverage
 - 60 gallon, 7 nozzle 140" coverage

MODEL	DESCRIPTION	WEIGHT	LIST PRICE
LG30TRL	30 gallon, 2 nozzle, 80" spray coverage 12V pump with 13" pneumatic tires	62 lbs.	\$589
TR40EX	40 gallon, 5 nozzle, 100" spray coverage 12V pump with 15/600 x 6 pneumatic tires	205 lbs.	\$1059
ATVTS6012V	60 gallon, 7 nozzle, 140" spray coverage 12V pump, 18 x 9.5 x 8 pneumatic tires	295 lbs.	\$1999

OPTIONS:

MODEL	DESCRIPTION	LIST PRICE
7772014	Multi lid measuring device	\$35

ATV & UTV SPRAYERS



- * Corrosion resistant polyethylene tanks
- * Lower tank profile for improved stability
- * Full drain out capability with molded in drain port, cap & tether
- * Full length drain sump
- * Large pickup sump
- * 5" fill lid with tether
- * Both gallon (US) and litre fluid volume indicator
- * Includes 5 nozzle, 100" spraying width, 3 section folding boom
- * Includes deluxe pistol grip handgun with adjustable nozzle and 25 ft. of hose
- * 12 volt, 2.1 gpm, 45 psi diaphragm pump
- * Pressure gauge - adjustable pressure
- * "On-Off" switch
- * Steel skid type frame assembly

MODEL	DESCRIPTION	WEIGHT	LIST PRICE
UTL405	40 gal. UTV with 5 nozzle, 3 section boom 12 volt, 2.1 GPM pump. Mounts in rear box	117 lbs.	\$1139

OPTIONS:

MODEL	DESCRIPTION	LIST PRICE
7772014	Multi lid measuring device	\$35

Weights indicated are base machine weight, not shipping weight

SPRAYER

3 Pt. Hitch



[Click for Video](#)

40 gal. Cat. I, 3 Pt. sprayer for sub-compact and compact tractors for the application of pesticides, herbicides, insecticides or fungicides. Four nozzle boom with 120" spray coverage, 3 section boom features break-away hinges for transport or striking objects such as trees or post when spraying.

- * 40 U.S. gallon polyethylene tank
- * 12 volt diaphragm demand style pump
2.1 gpm, 0-60 psi
- * Break away hinges on boom
- * 4 nozzle, 3 section Fold Behind Boom
- * 120" spray coverage
- * Deluxe pistol grip handgun with 15 feet of hose
- * Pressure gauge
- * 8 ft. lead wire with remote switch
- * Cat. I, 3 Pt. hitch

MODEL	DESCRIPTION	WEIGHT	LIST PRICE
LG403PT12V	40 Gal. US 3 Pt hitch sprayer 12V pump, 120" spray coverage	80 lbs.	\$849

OPTIONS:

MODEL	DESCRIPTION	LIST PRICE
7772014	Multi lid measuring device	\$35

SPRAYER

3 Pt. Hitch



LG603PT

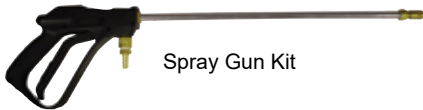

Spray Gun Kit



Pump

60 Gal. (U.S.) Cat. I 3 Pt hitch sprayer for compact tractors for the application of pesticides, herbicides, insecticides or fungicides. 3 section, 7 nozzle boom, fold behind, coverage 140" features break-away hinges on boom.

- * 60 U.S. Gallon Polyethylene tank
- * 7 Nozzle, 3 section fold behind boom
- * Comes with TP8002VP Spray tips
- * Break-Away Hinge on Boom
- * 140" Spray Coverage
- * 6 Roller Ni-Resist Pump with PTO Coupler
- * Deluxe pistol Grip Hand gun with 25' of hose
- * Single Manual Lever Valve Boom Control
- * Relief Valve for Pressure Adjustment
- * Pressure Gauge

MODEL	DESCRIPTION	WEIGHT	LIST PRICE
LG603PT	60 gal. US 3 Pt hitch sprayer with 6 roller Ni-Resist PTO pump	265 lbs.	\$2199

SPRAYER FOAM MARKERS

TrailLine



TJEV24



TJ15G



TJ1G

A foam marker can be a simple solution to mark your sprayed area through deposits of balls or ribbons of foam. It's the most common and economical way to avoid over or under application of crop protection chemicals. Kits include a 12 volt compressor, a solution tank, control box, and all the parts necessary for installation on any type of spraying equipment.

- * **Control box with electrical switch and safety fuse to direct foam to either side**
- * **6' power cable**
- * **15' compressor cable**

MODEL	DESCRIPTION	WEIGHT	LIST PRICE
TJEV24	6.4 Gal. poly tank, 108' poly 6 x 4 air/liquid tube covered by a flexible sheathing. 6" vertical foam drop nozzles with adjustable supports and diffuser bells.	41 lbs.	\$1019
TJ15G	15 Gal. poly tank, 118' poly 6 x 4 liquid and 6 x 8 air tube covered with a soft sheathing, horizontal foam nozzles complete with new compact style angular diffuser bells and adjustable supports.	50 lbs.	\$1269
TJ1G	ATV sprayer foam marker, includes 1 Gal. tank, 2 foam outputs, 2 x 6' of tubing, remote switch control	16 lbs.	\$689

ATV - UTILITY VEHICLE **Tufline**

Attachments



[Click for Video](#)

ATV DISC

Designed to work behind larger ATV's (450cc & up) and utility vehicles. This heavy duty ATV disc is ideal for soil preparation and ground breaking.

- * Heavy duty 2" square tube frame
- * 16" notched disc blades
- * Adjustable gang angle
- * 1" square axle shafts with sealed ball bearings
- * 7-1/2" blade spacing
- * Ratchet turnbuckle height adjustment
- * Pneumatic tires on 8" rims
- * 1-7/8" ball hitch

MODEL	DESCRIPTION	WEIGHT	LIST PRICE
ATVD7816-2	52" working width ATV disc (8) 16" disc blades	347 lbs.	\$1999
ATVD71016	64" working width ATV disc (10) 16" disc blades	498 lbs.	\$2599

ATV OFFSET DISC



For 600 cc ATV's and larger and compact tractors. Available in 42", 48" & 56" working widths. Comes with 16" notched disc blades, with 9" blade spacing on dual disc gangs which creates a more aggressive & deeper cut. Tufline has developed a unique side draft and disc pressure adjustment system that keeps the unit tracking behind power unit.

- * Heavy duty 3" square tube frame
- * Adjustable angles for each gang
- * Rated for 600cc ATV & above
- * 9" blade spacing
- * 16" notched disc blades
- * 1 7/8" ball hitch

MODEL	DESCRIPTION	# BLADES	WEIGHT	LIST PRICE
UTD91016	42" Cutting Width	10	528 lbs.	\$3149
UTD91216	48" Cutting Width	12	564 lbs.	\$3249
UTD91416	56" Cutting Width	14	605 lbs.	\$3359

Weights indicated are base machine weight, not shipping weight

ATV - UTILITY VEHICLE **Tufline** Attachments

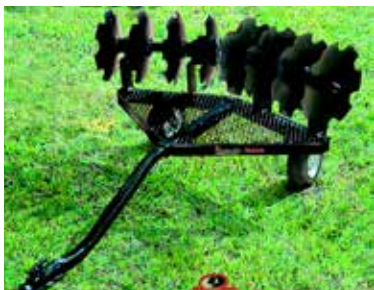

[Click for Video](#)

Tufline's Flip Discs are an economical choice for use with ATV's 250 cc to 400 cc and small garden tractors.

- * Formed tube steel main frame
- * 52" cutting width
- * Eight 16" notched disc blades
- * 7-1/2" blade spacing
- * 1" square hi-strength gang axle
- * Weight tray for added weight when needed
- * Cast iron friction bearings with grease fittings offer long life
- * 1-7/8" ball hitch
- * Two 4.10 – 6 pneumatic transport tires

MODEL	DESCRIPTION	# BLADES	WEIGHT	LIST PRICE
ATVFD7816	52" Flip Disc	8	245 lbs.	\$1449

ATV LAND PLANE



The Monroe Tufline ATV Land Plane is designed to be pulled by larger ATV's, UTV's and small compact tractors. Available in 2 working widths, 4' and 5'. Dual angled moldboards for maximum smoothing of gravel driveways, landscaping etc. Ratchet height adjustment, replaceable cutting edges, pneumatic tires and a 1-7/8" ball hitch.

MODEL	DESCRIPTION	WEIGHT	LIST PRICE
ATVLP48	48" Working width	365 lbs.	\$2349
ATVLP60	60" Working width	415 lbs.	\$2429

ATV - UTILITY VEHICLE *Tufline*

Attachments

[Click for Video](#)

ATV GRADER / SCRAPER BLADES

- * Angle adjustment, left or right
- * Moldboard height 15"
- * Pneumatic tires on 8" rims
- * 1-7/8" ball hitch



MODEL	DESCRIPTION	WEIGHT	LIST PRICE
ATVG48	4' (48")	215 lbs.	\$1479
ATVG60	5' (60")	230 lbs.	\$1549

ATV BOX SCRAPER

- * Manual lift lever for height adjustment
- * 1/8" thick plate box frame
- * Pneumatic tires on 8" rims
- * 1-7/8" ball hitch



MODEL	DESCRIPTION	WEIGHT	LIST PRICE
ATVB48	4' (48") Box blade	205 lbs.	\$1429

ATV LANDSCAPE RAKE

- * Manual lift lever for height adjustment
- * 15" spring steel rake tines, mounted on 1" centers
- * Pneumatic tires on 8" rims
- * 1-7/8" ball hitch



MODEL	DESCRIPTION	WEIGHT	LIST PRICE
ATVLR48	4' (48") Landscape rake	192 lbs.	\$1699
ATVLR60	5' (60") Landscape rake	203 lbs.	\$1829
ATVLR72	6' (72") Landscape rake	235 lbs.	\$1999

CHAIN HARROWS

Hackett Harrows



[Click for Video](#)

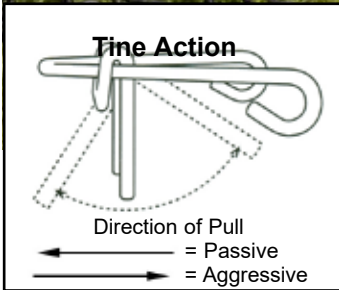

HACKETT HARROWS are designed to cover all applications from large farms to smaller hobby farms and equestrian venues. The Hackett Harrow is ideal for all types of ground work, by improving ground conditions by removing thatch, breaking up clods, working in fertilizer and breaking up and leveling soil, in established pastures, paddocks, park lands, small acreages, race tracks and horse arenas. The Hackett Harrows is manufactured in the U.K. from high quality steel, which ensures that the harrow is extremely strong with high resistance to wear. Harrows are available in 4 ft. 6 ft. 8 ft. 12 ft. and 16 ft. widths, x 4 ft. or 8 ft. long.

- * Tine size 1/2" x 3-1/2"
- * Sixty tines per 4 foot section
- * High quality, high carbon steel tines

- * Heat treated at optimum temperatures to ensure high resistance to wear

PULL TYPE HARROW SETS COMPLETE WITH DRAWBAR

WIDTH X LENGTH	CONTENTS	WEIGHT	LIST PRICE
4' x 4'	1-CC044 & 1-DB04U	105 lbs.	\$325
6' x 4'	1-CC064 & 1-DB06U	165 lbs.	\$445
8' x 4'	2-CC044 & 1-DB08U	203 lbs.	\$585
12' x 4'	3-CC044 & 1-DB12U	301 lbs.	\$895
16' x 4'	4-CC044 & 1-DB16U	402 lbs.	\$1250
4' x 8'	2-CC044 & 1-DB04U	179 lbs.	\$530
8' x 8'	4-CC044 & 1-DB08U	351 lbs.	\$995
12' x 8'	6-CC044 & 1-DB12U	523 lbs.	\$1495
16' x 8'	8-CC044 & 1-DB16U	698 lbs.	\$2045

TREE & POST PULLER Intimidator



[Click for Video](#)

A true land-clearing, obstacle-removing attachment for your skid-steer or tractor, the Intimidator is ideal for eliminating trees, saplings, shrubs, bushes, and other obstructions on the job site or farm. The unmatched versatility of the Intimidator handles the toughest stumps, posts, rocks, fencerows, and land-clearing jobs. Selectively eliminate what you want. Maneuver into tight locations and next to buildings or fences with ease. Remove the complete tree or stump, roots and all. Remove larger trees, even with smaller skid-steers or tractors, using the replaceable excavator bucket teeth and vertical jaw saw teeth to dig and cut roots.

- * Incorporates a tree/post puller, stump bucket, and rock picker all in one
- * Can maneuver into tight locations and next to buildings and fences
- * Dig and cut roots using the replaceable excavator bucket teeth and vertical jaw saw teeth for large tree removal and/or stumps
- * Synchronized jaws are actuated by a rear mounted 3" diameter cylinder

MODEL	DESCRIPTION	WEIGHT	LIST PRICE
DU12200	Skid steer quick attach	630 lbs.	\$4459
DU12200T	Skid steer quick attach with side saw teeth jaws	642 lbs.	\$4749
DU12201	Euro/Global quick attach	643 lbs.	\$4699
DU12200F	Flat back (for custom fabrication)	740 lbs.	\$4949

TREE SAW HYDRAULIC, SKID STEER



The BROWN Tree Saw is designed for skid steer is a rugged machine that can handle selective clearing of wood lots, fence rows, food plots and ATV / bike trails. The heavy construction is tough enough to cut heavy brush and trees up to eight inches in diameter. All models have an electric over hydraulic rotating head for trimming limbs and sizing logs for easy removal. Mining grade saw blade tips are used to allow below ground cutting when desired. Machines are available with either industry standard hydraulic gear motors or cutting edge "Bent Axis Piston" motors.

- * **90 Degree Rotating Head**
- * **30" Blade with 10 Replaceable Carbide Teeth**
- * **All Welded Construction**
- * **Limb & Brush Guard Included**
- * **5 U.S. Gallon Herbicide Tank with Adjustable Spray Nozzle**
- * **Includes Hydraulic Hoses and Couplers**
- * **Includes 3 Button Wiring Harness**
- * **Optional 8 Pin or 14 Pin Connectors Available**

MODEL	DESCRIPTION	GPM REQ'D	WEIGHT	LIST PRICE
HTS3020	with hydraulic gear motor	15-25GPM	1020 lbs.	\$19,299
HTS3040	with hydraulic gear motor	26-42GPM	1020 lbs.	\$19,299
HTS3020BA	with hydraulic bent axis motor	15-25GPM	1020 lbs.	\$22,699
HTS3040BA	with hydraulic bent axis motor	26-42GPM	1020 lbs.	\$22,699

Special Order, Allow 30 days for delivery

TREE SAW 3 Pt. HITCH



TS100 Model Shown

[Click for Video](#)



TSG200 Model Shown

The BROWN TREESAWS are designed to be rugged machines that can handle selective clearing of wood lots, fence rows, food plots, ATV/bike trails etc. the heavy construction is tough enough to cut heavy brush and trees up to 8" in diameter. The balanced blade keeps vibration to a minimum. The TS100 comes with a rigid brush bar for controlling brush and trees as you cut them. The TSG200 comes with a hydraulic grapple for moving brush and cut trees after cutting. Both units include a brush guard to protect operator.

- * **Minimum HP required 35 HP**
- * **Cat. 1 3 Pt. Hitch**
- * **Height of cut: ground level**
- * **All welded construction**
- * **Gear Box Ratio 1: 1.5**
- * **540 RPM PTO**
- * **36" Blade with replaceable carbide teeth**

MODEL	DESCRIPTION	WEIGHT	LIST PRICE
TS100	TREESAWS with brush guard	850 lbs.	\$7999
TSG200	TREESAWS with hydraulic grapple & brush guard (includes hydraulic hose)	1050 lbs.	\$9699

LOGGING WINCHES

Fransgård

**INSTANT
REBATE !**

\$1,000 on V4000 & V6500

\$500 on V3004, V3507
& V5000

[Click for Video](#)

Complete
our form for your
INSTANT
REBATE !



The **Fransgård** winch was designed and manufactured in Denmark for over 30 years. Its robust design, and extra weight, will provide great traction and enable skidding logs, even in narrow trails. The heavy-duty butt plate and tow bar, can be sued for dozing the logs, and levelling trails. All winches have a cam-activated clutch system

- * All winches include PTO, cable & protective safety screen
- * Specially designed cable resists friction for longer wearing life
- * 1 year limited warranty on manufacturing defects.
- * Owners manual and parts book provided with every winch
- * All winches have a cam-activated clutch system
- * PTO hookup ground clearance specifications enable choosing the ideal model for your tractor
- * Top pulley is mounted on bearings, and extra supports provides additional resistance for heavy loads
- * Cable drum tension bracket prevents cable from unspooling

MODEL	PULL CAP.	WEIGHT	TRACTOR HP REQ'D	CABLE LENGTH	CABLE DIA.	LIST PRICE
V3004	6600 lbs	385 lbs.	25	133'	5/16"	\$4549
V3507	7700 lbs	408 lbs.	25	133'	5/16"	\$4699
V4000	8800 lbs	657 lbs.	40	167'	3/8"	\$5699
V5000	11,000 lbs	687 lbs.	40	167'	3/8"	\$5999
V6500	14,300 lbs	972 lbs.	80	167'	7/16"	\$8989

CAUTION: Timber winches are mounted very close to the tractor for maximum stability, therefore PTO length is critical. Stock length shaft supplied may require shortening to suit tractor. Operator should ensure that the PTO is never operated at over a 30 degree angle. Three point hitch linkage must have lower setting adjusted so winch does not dig into soft ground pulling the or breaking the PTO shaft. There is no warranty on PTO shafts and knuckles broken or bent under the circumstances listed above. Never transport logs hooked to top of winch by cable, always use chains hooked to transport bar which gives a lower center of gravity.

NOTE: Please review owners manual as there are specific operating and maintenance instructions - cables are considered a wearing part and are not covered by warranty.

Not available in Quebec

104

Weights indicated are base machine weight, not shipping weight

LOGGING WINCH Accessories

Fransgård

**INSTANT
REBATE !**

\$1,000 on V4000 & V6500
\$500 on V3004, V3507
& V5000

Complete
our form for your
**INSTANT
REBATE !**



MODEL	DESCRIPTION	LIST PRICE
1525	Cable 5/16" x 133' (for use with V2800,V3004,V3507)	\$225
1546	Cable 3/8" x 167 ft (for use with V4000,V5000)	\$379
1556	Cable 7/16" x 167 ft - for use with V6500	\$469
1562	End hook for cable	\$17
1582	Choker/Slider	\$35
1584	Choker chain 7' silver (for use w/V3004 & V3507. Work load 2200lbs/1000kg)	\$55
1586	Choker chain heavy duty 7' red (for use with V4000 & V6500 Work load 6615 lbs/3000kg)	\$99
1588	Choker chain heavy duty 10' red (for use with V4000 & V6500 Work load 6615 lbs/3000kg)	\$125
1593	Middle Pulley for V3004 and V3507	\$145
1595	Distance Pulley - 4000 kg / 8800 lbs.	\$469
1596	Distance Pulley - 13000 kg / 28600 lbs.	\$1179

Weights indicated are base machine weight, not shipping weight

STUMP GRINDERS

3 Pt. Hitch



[Click for Video](#)

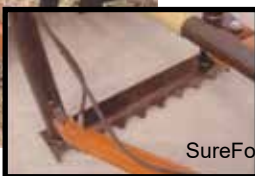

SureFoot Stabilizer Bar

This **WORKSAVER** economical and efficient PTO powered stump grinder makes stump removal fast & easy. The operator easily controls the stump grinder from the comfort of their tractor seat.

- * **Maneuverable - goes anywhere a tractor can.**
- * **Cutting wheel design provides a smoother cutting action.**
- * **Durable carbide -tipped cutting teeth are economical and easy to replace.**
- * **SUREFOOT stabilizer bar provides solid footing during operation.**
- * **Rubber deflector helps control chips during grinding.**
- * **Hardened bushings used in major pivot points for increased reliability.**

MODEL	SG26 (3 Pt)	SG36 (3 Pt)
LIST PRICE	\$8759	\$9999
Hitch	Cat. 1	Cat. 1 and 2
Overall Length	75"	80"
PTO Driveline	Series 5	Series 6
Driveline Protection	Slip Clutch	Slip Clutch
Gearbox Rating	60 HP	100 HP
Cutting Wheel Thickness	3/4"	3/4"
Cutting Wheel Diameter	26"	36"
# Of teeth	30	39
Cutting Ht Above Ground	18"	18"
Cutting Ht Below Ground	10"	10"
Max. Cut Depth Per Pass	5"	8"
Max. horizontal cut	28"	33"
Swing Arc	45°	45°
HP Requirement	22-50	45-100
Weight	660 lbs.	880 lbs.

OPTIONS:

MODEL	DESCRIPTION	LIST PRICE
811600	Box of 12 replacement carbide teeth with bolts and washers	\$335

GRAPPLE

SATG: Sweep Action Tine Grapple



[Click for Video](#)

The Sweep Action Tine Grapple (SATG) is described as one tool, with many applications, demanded for clearing rocks, brush, wood, metal, and other material. The patent pending design keeps the front rake of the sweep clamp open during use until the rear section of the clamp is either closed or contacts the material being handled. The cylinder then overcomes the spring pressure causing the front rake to rotate towards the bucket in a sweeping motion moving material in, and retaining it in the bucket.

- * Available in three sizes 72", 78" & 84"
- * Bucket Depth 31"
- * Grapple opening 37"
- * 44 Degrees of sweeping action
- * Tine material 1/2" thick steel
- * Tine spacing 5"
- * Universal skid steer quick attach brackets
- * Includes hydraulic hose and "Connect Under Pressure" flat face couplers

MODEL	DESCRIPTION	WEIGHT	PRICE
SATG72	72" wide Sweep Action Grapple	847 lbs.	\$5279
SATG78	78" wide Sweep Action Grapple	893 lbs.	\$5999
SATG84	84" wide Sweep Action Grapple	923 lbs.	\$6179

GRAPPLE RAKES

Compact Tractors up to 40 HP



[Click for Video](#)



WORKSAVER grapple rakes for skid steer and tractor front loaders are ideal for loading logs, picking rocks, and orchard prunings. Can be used for raking and piling brush and other hard to handle materials. Skid steer models use "Universal attaching" system for quick convenient method of hook-up. Tractor front loader mounting brackets extra. Pin type or quick attach brackets available.

- * **Single grapple**
- * **Single cylinder controls upper grapple**
- * **Optional interfacing quick-attach bracket available to fit most John Deere, AGCO, Kubota, CNH, and other brands of loaders.**
- * **The FLGR-4062S is used on OEM loaders that utilize the skid steer quick-attach system**

MODEL	APPLICATION	WIDTH	WEIGHT	LIST PRICE
FLGR4062	Front Loader	60"	277 lbs.	\$2699
FLGR4062S	Front Loader with skid steer quick-attach system	60"	355 lbs.	\$2959
NOT FOR USE ON SKID STEER LOADERS				

GRAPPLE RAKES

Tractors / Skid Steer



WORKSAVER grapple rakes for skid steer and tractor front loaders are ideal for loading logs, picking rocks, and orchard prunings. Can be used for raking and piling brush and other hard to handle materials. The split top design provided dual upper grapples for picking up brush and other debris while leaving the dirt behind. Skid steer models use "Universal attaching" system for quick convenient method of hook-up. Tractor front loader mounting brackets extra. Pin type or quick attach brackets available.

- * **Two working widths 62" and 77" with 4 grapple tines**
- * **Tine spacing 15" center to center**
- * **Grapple opening 50"**
- * **Grapple depth 25"**
- * **Reinforced tubes welded between lower tines for added strength**
- * **Includes hydraulic cylinders, less hoses**

MODEL	APPLICATION	WIDTH	WEIGHT	LIST PRICE
FLGR262	Front Loader	62"	811 lbs.	\$4519
FLGR277	Front Loader	77"	958 lbs.	\$5229
SSGR262	Skid Steer	62"	820 lbs.	\$5029
SSGR277	Skid Steer	77"	965 lbs.	\$5719

OPTIONS:

MODEL	DESCRIPTION	LIST PRICE
811395	Parking Stand Kit, 26 lbs Allows upright storage and easy hook up on hard surfaces	\$269

Weights indicated are base machine weight, not shipping weight

GRAPPLES FOR ROCK BUCKETS



MDS provides a grapple attachment for most of their rock buckets. These 4 high-strength, T-1 steel tine units bolt on to the grapple, and the tine spacing is adjustable. These grapples include hydraulic cylinders (less hoses to tractor). The grapple can extend to a 71" opening.

MODEL	DESCRIPTION	WEIGHT	LIST PRICE
GF4	Fits 7' to 9' ALO mounts or 6' to 9' SS mounts	450 lbs.	\$3179



U-BOLT ON QUICK ATTACH BRACKETS

MODEL	DESCRIPTION	WEIGHT	LIST PRICE
5520	Universal skid steer quick attach brackets	150 lbs.	\$639
5220	ALO, EURO, GLOBAL quick attach brackets	125 lbs.	\$639

ROCKBUCKET



The MDS Rock Bucket will save you hours of time and effort. Super tough 1045 hardened tines (weldable), integrated rock dam, 3/8" side plates, and a 72" grapple opening (optional) makes this the perfect tool for your operation. Available for skid steers, telehandlers, and over 85 different tractor loaders. Available in 48", 60", 72", 84" and 96", the MDS Rock Bucket is ideal for the farm, ranch, construction site and more. MDS Manufacturing Company Inc. is a third generation, family owned company that has been serving the agricultural community for over 50 years.

LIGHT DUTY ROCK BUCKET 1.125" TOOTH DIA. X 1.75" SPACING

	WORKING			# OF	WEIGHT	LIST
MODEL	WIDTH	DEPTH	HEIGHT	TEETH	(LBS.)	PRICE
LRB418	4' / 48"	46"	26"	17	570	\$2049
LRB518	5' / 60"	46"	26"	21	680	\$2519
LRB618	6' / 72"	46"	26"	25	795	\$2969
LRB718	7' / 84"	46"	26"	30	940	\$3519

MEDIUM DUTY ROCK BUCKET 1.25" TOOTH DIA. X 2.5" SPACING

	WORKING			# OF	WEIGHT	LIST
MODEL	WIDTH	DEPTH	HEIGHT	TEETH	(LBS.)	PRICE
MRB514	5' / 60"	46"	26"	16	675	\$2859
MRB614	6' / 72"	46"	26"	20	790	\$3019
MRB714	7' / 84"	46"	26"	23	900	\$3559
MRB814	8' / 96"	46"	26"	25	1015	\$4029

ROCK BUCKET

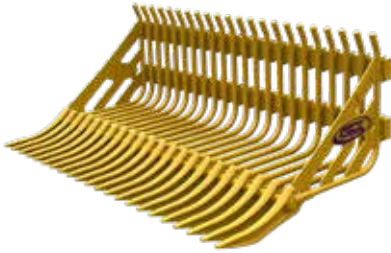

- * Each tooth made from spring steel.
- * Priced less mounting brackets

S. Houle rock buckets are unique on the market, with unmatched tip design and high quality steel tines, we ensure you have the most robust tool to accomplish the work you need to do. Our tips are specifically designed to support maximum weight up to 3 times what or competition can offer. Their specially designed profile offers a stopper that allows more volume capacity by keeping rocks and stones from tumbling out. We have such confidence in our product we offer a limited lifetime warranty on tips. We offer 4 different tine sizes of rock buckets in various working widths. All rock buckets are priced less loader mounting brackets.

BB Series

**STANDARD ROCK BUCKET 1.125" TOOTH DIA. X 2.5" SPACING
TENSILE STRENGTH - 83,077 Lbs.**

	WORKING			# OF	WEIGHT	LIST
MODEL	WIDTH	DEPTH	HEIGHT	TEETH	(LBS.)	PRICE
BB4W	4' / 48"	37"	24"	14	397	\$1999
BB5W	5' / 60"	37"	24"	17	477	\$2439

B Series

**STANDARD ROCK BUCKET 1.25" TOOTH DIA. X 2.5" SPACING
TENSILE STRENGTH - 112,500 Lbs.**

	WORKING			# OF	WEIGHT	LIST
MODEL	WIDTH	DEPTH	HEIGHT	TEETH	(LBS.)	PRICE
B6	6' / 72"	42"	24"	19	760	\$3299
B7	7' / 84"	42"	24"	22	875	\$3399
B8	8' / 96"	42"	24"	25	990	\$3499

HB Series

**HEAVY DUTY ROCK BUCKET 1.5" TOOTH DIA. X 3" SPACING
TENSILE STRENGTH - 135,000 Lbs.**

	WORKING			# OF	WEIGHT	LIST
MODEL	WIDTH	DEPTH	HEIGHT	TEETH	(LBS.)	PRICE
HB6	6' / 72"	42"	24"	16	820	\$3599
HB7	7' / 84"	42"	24"	17	990	\$3799
HB8	8' / 96"	42"	24"	22	1110	\$4129
HB9	9' / 108"	42"	24"	25	1375	\$4499

Call your local dealer for the availability and pricing on heavy duty S. Houle loader quick attach brackets for your loader.

ROCK BUCKETS & GRAPPLES

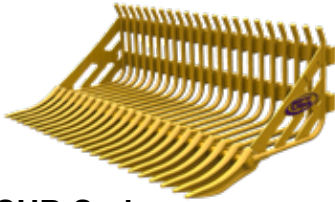

SHB Series require special loader mounting brackets. **Price on Request**
Call your local dealer for availability and pricing on heavy duty U-Bolt type quick attach brackets for your loader

SHB Series

SUPER HEAVY DUTY ROCK BUCKET 1.75" TOOTH DIA. X 4" SPACING TENSILE STRENGTH - 157,500 Lbs.						
	WORKING			# OF	WEIGHT	LIST
MODEL	WIDTH	DEPTH	HEIGHT	TEETH	(LBS.)	PRICE
SHB8	8' / 96"	42"	24"	18	2075	\$4999

GRAPPLES

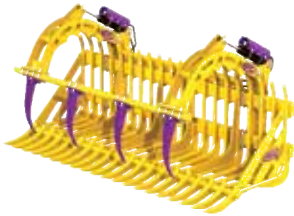

Houle provides two models of Grapple attachments for their **rock buckets** depending on the model. Units bolt on to buckets, and include two 2-1/2" x 18" hydraulic cylinders, (less hydraulic hoses to tractor), & four replaceable hardened steel teeth. Units are easily detached from bucket when not required.

MODEL	DESCRIPTION	WEIGHT	LIST PRICE
GP10	Fits 6' to 9' B & HB Rock Buckets	625 lbs.	\$2499

U-BOLT ON QUICK ATTACH BRACKETS



IN200003

S. Houle Fabrication U-Bolt-On quick attach brackets are manufactured extra heavy duty to withstand the punishment of digging and picking stones and rocks. Designed and built to allow more roll back on bucket.



IN2000002
Alo Loaders

MODEL	DESCRIPTION	WEIGHT	LIST PRICE
IN20E12	U-Bolt-On 1" pin type loader brackets (pair)	70 lbs.	\$275
IN2200003	U-Bolt-On universal skid steer quick attach bracket (pair)	125 lbs.	\$579
IN2000002	U-Bolt-On ALO, EURO or GLOBAL quick attach bracket (pair)	115 lbs.	\$579
IN01-00013	U-Bolt-On John Deere 620, 640, 720, 725, 740, 741 quick attach brackets (pair)	160 lbs.	\$599

Also available many more brackets to fit Allied (Farm King), Alo, Case IH, JD, FNH, Cat, Kubota, MF. etc. Check with your local dealer for the availability of brackets for your loader.

Weights indicated are base machine weight, not shipping weight

GRAPPLE BUCKET LOW PROFILE SKID STEER



Model LPSB



Model LPTG

WorkSaver's NEW Low Profile Grapple Buckets come in two different styles, Tine Bottom and Solid Bottom. Available in four models, all with a split grapple assembly with 2 hydraulic cylinders with cylinder guards to protect cylinders and hoses. These NEW Grapple Buckets are manufactured to attach to any skid steer with the "universal" skid steer quick attach mounting system. Comes with hydraulic hoses and "connect under pressure" flat faced couplers.

- * 72" & 84" overall width
- * Split grapple assembly
- * Tine grapple has 7 1/2" spacing
- * Scrap bucket cutting edge is pre-drilled to accept optional replaceable bevelled cutting edge
- * Complete with "connect under pressure" flat faced couplers
- * Two 2"x10" Hyd cylinders with cylinder guard protection
- * Universal skid steer quick attach mounting bracket

MODEL	DESCRIPTION	WEIGHT (LBS.)	LIST PRICE
LPTG72A	72" Low profile tine grapple bucket	820 lbs.	\$4519
LPTG84A	84" Low profile tine grapple bucket	898 lbs.	\$5429
LPSB72A	72" Low profile scrap grapple bucket	760 lbs.	\$4649
LPSB84A	84" Low profile scrap grapple bucket	855 lbs.	\$5729

OPTIONS: FOR LPSB72 OR LPSB84 SCRAP BUCKET

MODEL	DESCRIPTION	LIST PRICE
811790	3/4" x 8" x 72" reversible cutting edge & hardware	\$599
811870	3/4" x 8" x 84" reversible cutting edge & hardware	\$689

MANURE FORKS



M/SG-72S



M/S-66S

The Worksaver Manure Fork was designed for picking up manure, matted straw or other loose materials. Excellent for handling silage, units with upper grapple helps secure load during transport improving productivity. All units have forged cranked tines for extended service life. Units with upper grapple and skid steer mount are supplied with hydraulic hoses and connect under pressure couplers for ease of installation. Models with upper grapple have greasable pivot points for long life and cylinder pivot points utilize replaceable harden bushing to reduce wear.

- * Available in 66" & 72" widths
- * Available with or without upper grapple
- * Overall depth 31" / 787mm
- * Overall height 21.5" / 546mm
- * Useable tine length 27" / 686mm
- * Upper grapple width 34" / 864mm
- * Tine spacing 7.5" / 190mm
- * Number of tines 66" - 9, 72" - 10

Units come with Universal Skid Steer quick attach plate. Includes hydraulic hoses and flat face couplers.

MODEL	DESCRIPTION	WEIGHT	LIST PRICE
MS66S	Manure fork 66" wide	240 lbs.	\$1559
MS72S	Manure fork 72" wide	270 lbs.	\$1619
MSG72S	Manure fork 72" wide with upper grapple	450 lbs.	\$3619

Units require Optional Bolt-on Quick Attach Brackets. To be ordered separately. Units with upper grapple come LESS hydraulic hoses & couplers.

MODEL	DESCRIPTION	WEIGHT	LIST PRICE
MS60U	Manure fork 60" wide	225 lbs.	\$1499
MS72U	Manure fork 72" wide	270 lbs.	\$1619

PALLET FORKS



- * **Clamp-On to material loader Bucket**
- * **Available in three sizes**
- * **No tools required to install**

MODEL	DESCRIPTION	WEIGHT	PRICE
BF1000	1000 lb capacity, 35" usable length, pair.	78 lbs.	\$599
BF2000	2000 lb capacity, 42" usable length, pair.	102 lbs.	\$669
BF4000	4000 lb capacity, 42" usable length, pair.	168 lbs.	\$1099



- * **1-1/4" x 4" solid forks with spring loaded toggle latch for positioning**
- * **Skid steer mount units have step through design**

MODEL	DESCRIPTION	WEIGHT	LIST PRICE
SSPF442	Pallet forks 4000 lb. rated, 42" long to fit skid steer or tractor loaders with universal skid steer attach system	345 lbs.	\$1429
SSPF448	Pallet forks 4000 lb. rated, 48" long to fit skid steer or tractor loaders with universal skid steer attach system	359 lbs.	\$1429
PF448	Pallet forks 4000 lb. rated, 48" long to fit tractor loaders. Designed to mount to tractor loaders with centre to centre between arms up to 50" Optional interfacing quick attach brackets extra	438 lbs.	\$1579

Pallet forks available for John Deere 400/500 series loaders and loaders with GLOBAL / EURO attaching system

COMPACT PALLET FORKS

For 40 HP Tractors / Loaders



These newly designed compact pallet forks from Worksaver incorporates many of the same durability features found in our larger units. These models utilize Class I forks (1" x 4" x 42") rated at 2,400 lbs. for the pair providing optimal lifting capacity. Spacing adjustment is easy with spring loaded latches allowing the operator to move the forks along the notched rail.

- * **Class I solid steel alloy forks**
- * **Forks are 1" x 4" x 42" rated @ 2400 lbs. / pair**
- * **Rail style forks with spring loaded latches**
- * **2 models available for tractors with loaders up to 40 HP**

MODEL	DESCRIPTION	WEIGHT	LIST PRICE
SSPF242	Pallet forks 2400 lb. rated to fit loaders with universal skid steer attaching systems	290 lbs.	\$1149
JDPF2000	Pallet forks 2400 lb. rated to fit John Deere 200 / 300 Series with JD quick attach system	280 lbs.	\$1189

ESTATE YARD RAKE

ESTATE RAKE™

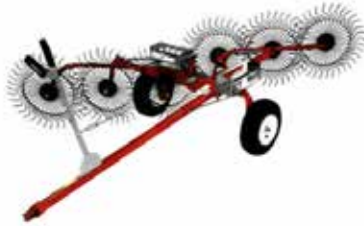

The Edney Estate Rake windrows and rakes lightly without damaging growing grasses. By adding weight to the weight boxes, becomes a de-thatcher or more aggressive rake. In most conditions, several windrows can be rolled together to save pickup time. These are uniquely designed for flexibility on uneven ground and areas too large to do by hand.

- * **Pneumatic tires standard, provide greater stability**
- * **Working width 48"**
- * **Uses 6 x 18" rake wheels**
- * **Hitch folds for storage**
- * **Arms lift for transport**
- * **Ships in 2 boxes**

MODEL	DESCRIPTION	WEIGHT	LISTPRICE
ER6	Estate Yard Rake	82 lbs.	\$769

FINGER WHEEL RAKES

3 Pt. Single Side

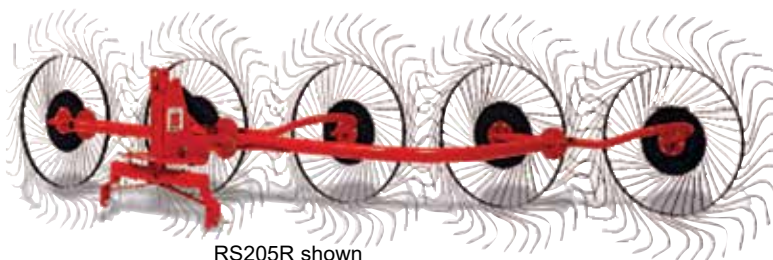

RS205R shown



RS202R shown

For tractors from 30 HP engine and up. Category 1 or 2, 3 Pt. hitch. Finger rake wheels are mounted on molded steel hubs with tapered bearings. Lifts hay gently, and evenly from undulating terrain. May also be used for raking, turning or spreading swathes. Its fast working speed makes it possible to cover a large acreage quickly. Having no gears, chains or other drive components to wear out, the finger wheel rake is truly a low maintenance tool.

- * **HP Requirements: 30-80**
- * **Cat. 1 3 Pt. hitch**
- * **Molded steel hubs with greasable tapered bearings**
- * **May also be used for raking, turning or spreading swathes**
- * **Lifts hay gently, even from undulating terrain**

MODEL	# WHEELS	MAXIMUM WORKING WIDTH	WEIGHT	LIST PRICE
RS202R	2	4' 3"	194 lbs.	\$1039
RS203R	3	6' 5"	291 lbs.	\$1529
RS204R	4	8' 6"	388 lbs.	\$2039
RS205R	5	11'	495 lbs.	\$2489
RS206R	6	12' 9"	602 lbs.	\$2969

ACTION HAY RAKE

AR2100 Series



[Click for Video](#)

All High Clearance Action Rakes features a KWIK PIK system for immediate clearance of windrows when raised, as well as greater clearance in the raking position and stability during transport. An adjustable hitch allows you to level the rake for efficient raking. The hitch jack can adjust windrow width to 3 different positions. Windrow widths range from 3' to 5'. Right and left side raking is done easily by turning either one of the wing transport valves off. Raking width is easily adjusted by a single pin & clip, and can be fine-tuned with the threaded turnbuckle screw. Rakes feature 60" diameter rake wheels, and offer an optional 49" center kicker wheel.

- * Adjustable fine tune spring allows proper rake wheel down pressure
- * Rake wheel pivot provides additional ground flexibility

MODEL	# WHEELS	RAKING WIDTH	WEIGHT	LIST PRICE
AR2108	8	15' - 19'	1400 lbs.	\$10,621
AR2110	10	18' - 22'	1670 lbs.	\$11,337
AR2112	12	20' - 24'	1860 lbs.	\$12,052

OPTIONS:

MODEL	DESCRIPTION	LIST PRICE
AROCKW	49" Center Kick Wheel	\$894

ACTION HAY RAKE

AR3100 Series

H&S

[Click for Video](#)



All High Clearance Action Rakes features a KWIK PIK system for immediate clearance of windrows when raised, as well as greater clearance in the raking position and stability during transport. An adjustable hitch allows you to level the rake for efficient raking. The hitch jack can adjust windrow width to 3 different positions. Windrow widths range from 3' to 5'. Right and left side raking is done easily by turning either one of the wing transport valves off. Raking width is easily adjusted by a single pin & clip, and can be fine-tuned with the threaded turnbuckle screw. Rakes feature 60" diameter rake wheels, and offer an optional 49" center kicker wheel.

- * **Spring suspension system allows each rake wheel to float independently over the ground.**
- * **Down pressure for ALL the wheels on each side is done by a single hand crank.**

MODEL	# WHEELS	RAKING WIDTH	WEIGHT	LIST PRICE
AR3108	8	15' - 19'	1800 lbs.	\$12,285
AR3110	10	18' - 22'	2000 lbs.	\$12,999
AR3112	12	20' - 24'	2250 lbs.	\$13,999

OPTIONS:

MODEL	DESCRIPTION	LIST PRICE
AROCKW	49" Center Kick Wheel	\$894

COMBI-RAKE RV

3 Pt. Hitch

Fransgård

[Click for Video](#)



The Fransgård Basket type rake is designed to deliver fast and even drying of your crop of hay. The pickup tines are lowered into working position by centrifugal force and follow the terrain contour in a uniform fashion. This rake can both windrow or act as a tedder.

RV300

- * Transport Width: 8 ft 2in
- * Working Speed: 8 to 15 km
- * HP Requirement: 30 HP
- * Number of tines: 10 per rotor
- * Tires: Two 15 x 6.00
- * CAT I, 3 Pt. hitch
- * 540 RPM PTO with slip clutch

RV390

- * Transport Width: 10 ft 8in
- * Working Speed: 8 to 20 km
- * HP Requirement: 40 HP
- * Number of tines: 14 per rotor
- * Tires: Two 15 x 6.00
- * CAT I, 3 Pt. hitch
- * 540 RPM PTO with slip clutch

MODEL	DESCRIPTION	WORKING WIDTH	WEIGHT	LIST PRICE
RV300	Rake / Tedder 3 Pt.	10' (300cm)	785 lbs.	\$7899
RV390	Rake / Tedder 3 Pt.	12' 8" (390cm)	1080 lbs.	\$9999

COMBI HAY RAKE

Fransgård



The Fransgard Combi Rake allows the user to do spreading, tedding, and raking. For spreading and tedding, the rakes arms are locked and the machine tilted forward, thus obtaining uniform spreading of the material. During the raking function, the rake tines are controlled in a cam track allowing the tines to be tilted upwards. This ensures very gentle treatment of the material. Continually variable adjustment of working width is carried out hydraulically from the drivers seat.

- * 40 HP Requirement
- * Working Width 11'5" – 14'5"
- * Transport Width 7'5"
- * 6 arms with 24 teeth each
- * PTO 400-540 RPM

MODEL	DESCRIPTION	WEIGHT	LIST PRICE
T14000P	Combi hay rake	800 lbs.	\$12,999

WINDROW MERGERS



H&S Mergers feature pick-up heads with independent head flotation. The pick-up head controller can be adjusted for height and tension. The right hand side merges, while the left hand side inverts with the optional shield. These have a 42" ribbed cross conveyor belt for high capacity of crop discharge. The cross conveyor speeds up when pickup speed is increased. All mergers feature an anti-wrap guard on the cross conveyor to protect against material wrapping on the shafts and destroying bearings. The 3 prong plastic teeth are easily replaceable. A standard hitch is included for pulling with a truck or tractor during transport. These also include standard taillights and transport locks. An optional self-contained hydraulic drive kit with PTO pump can be installed on the M9 Merger. This feature allows tractors with a minimum 5 gpm hydraulic capacity and 1 remote to operate the merger. Minimum 70 HP tractor required, with 16 GPM/2000 PSI.

- * 9' pickup head
- * Easily change between right and left merging position
- * Options include 2' conveyor extension, accelerator roller to fluff windrows, windrow inverter, and transport light cords.

MODEL	PICKUP WIDTH	CONVEYOR WIDTH	WEIGHT	LIST PRICE
M9	9'	42"	2970 lbs.	\$34,999

OPTIONS:

MODEL	DESCRIPTION	LIST PRICE
MM01	Accelerator Roller	\$1799
MM04	2' Conveyor Extension	\$1429
MM05	PTO Hydraulic Drive Kit	\$4459
HSM01	Windrow Inverter	\$389
TLPC	Transport Light Cord	\$199

HAY HANDLING ATTACHMENTS

Bucket Mount



BBSF20



CBSF2000

[Click for Video](#)



CBSF3028

MODEL	DESCRIPTION	WEIGHT	LIST PRICE
BBSF20	2,000 Lb. Bolt-on Bucket Bale Spear Single tapered forged tine for use with tight center bales	68 lbs.	\$485
CBSF2000	2,000 Lb. Clamp-on Bucket Bale Spear Chain and turnbuckle system. 42" long Single tapered forged tine for use with tight center bales.	79 lbs.	\$565
CBSF2028	3000 Lb. Clamp-on bucket Uses chain and turnbuckle system. Two 42" tapered forged spears	102 lbs.	\$875
CBSF3028	4000 Lb. Clamp-on bucket THREE bales spear. Uses 2 chains & turnbuckle system. Three 42" tapered forged spears	185 lbs.	\$1265

HAY HANDLING ATTACHMENTS FOR JOHN DEERE LOADERS & AL0 GLOBAL STYLE QUICK ATTACH LOADERS



[Click for Video](#)

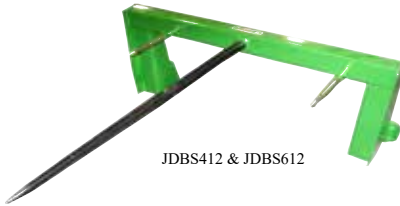

JDDBS412 & JDDBS612

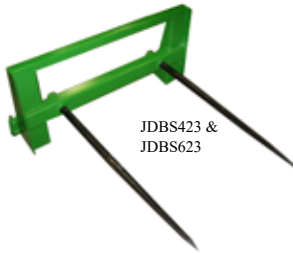

JDDBS423 &
JDDBS623

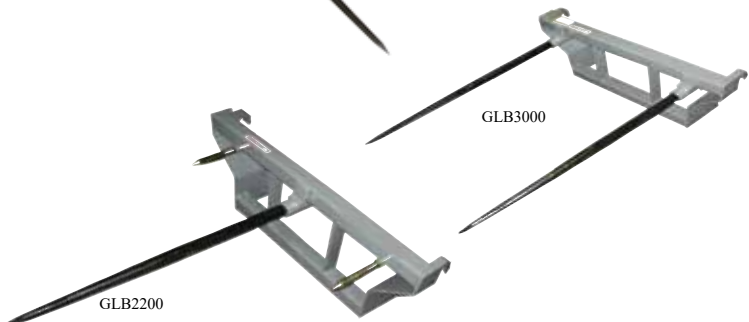

GLB2200

GLB3000



ELB340

HAY HANDLING ATTACHMENTS FOR JOHN DEERE LOADERS & ALO GLOBAL STYLE QUICK ATTACH LOADERS



For John Deere loaders
300,300CX,400X,410,420,430,440,460,520,521,540,541,542,553

MODEL	DESCRIPTION	WEIGHT	LIST PRICE
JDBS412	2200 lb. Single Loader Bale Spear 42" tapered forged spear with two 1" x 8-1/2" balance spikes	121 lbs.	\$829
JDBS423	3000 lb. Dual Bale Spear Two 42" forged tapered spears.	156 lbs.	\$1049

For John Deere loaders
620,640,720,721,725,726,740,741

MODEL	DESCRIPTION	WEIGHT	LIST PRICE
JDBS612	2200 lb. Single Bale Spear 42" tapered forged spear with two 1" x 8-1/2" balance spikes	176 lbs.	\$1129
JDBS623	3000 lb. Dual Bale Spear Two 42" forged tapered spears, spaced 30" apart	196 lbs.	\$1289

For Global/Euro Alo Quick Attach Loaders

MODEL	DESCRIPTION	WEIGHT	LIST PRICE
GLB2200	2200 lb. Single Bale Spear 42" tapered forged spear with two 1" x 8-1/2" balance spikes	114 lbs.	\$759
GLB3000	3000 lb. Dual Bale Spear Two 42" forged tapered spears, spaced 30" apart	128 lbs.	\$899
ELB340	4000 lb. rated Triple Spear spaced 26" apart with usable length of 42" for large size square bales	200 lbs.	\$1299

OPTIONS:

831095	Bolt-on Upright kit for handling two square bales.	32 lbs	\$115
--------	---	--------	-------

HAY HANDLING ATTACHMENTS

Front Loader or Skid Steer



FLBS3000



FLBS2200

[Click for Video](#)

MODEL	DESCRIPTION	WEIGHT	LIST PRICE
FLBS2200	2200 lb. rated Single Loader Bale Spear Single 42" tapered forged spear. Requires Optional Interfacing. Quick Attach Brackets (not included)	121 lbs.	\$685
FLBS3000	3000 lb. rated Dual Loader Bale Spear Two 42" forged tapered Spears. Requires Optional Interfacing Quick Attach Brackets (not included)	136 lbs.	\$815



SSB3000

MODEL	DESCRIPTION	WEIGHT	LIST PRICE
SSB3000	Skid Steer Double Bale Spear. Rated at 3000 lbs. Bolt-in tapered spears have usable length of 42". Designed to fit "universal" skid steer quick attach system	146 lbs.	\$929

HAY HANDLING ATTACHMENTS

3 Pt. Hitch Only



HHU2045

[Click for Video](#)



BSF1523

BALE SPEAR

MODEL	DESCRIPTION	WEIGHT	LIST PRICE
BSF1523	1,800 Lb. 3 Pt. Bale Spear Cat. 1 & 2. Single spear is 44" tapered forged spear for excellent penetration into the bale, w/welded balance spears.	60 lbs.	\$369

HAY HANDLER / BALE UNROLLER

MODEL	DESCRIPTION	WEIGHT	LIST PRICE
HHU2045	2,000 lb. 3 Pt. Hay Handler/Unroller 4' to 5' width & up to 6' diameter bales. Cat. 1, 2 & 3. 3 Narrow Quick Hitch. Use 2.5" x 8" Hydraulic Cylinder (Not included.)	310 lbs.	\$1499

HAY HANDLING ATTACHMENTS

Tractor Loader & Skid Steer Mount Bale Squeeze



GLBH2072



SSBH2072



GLBS48

The GLBH2072/SSBH2072 Bale Squeeze for up to 2200 lb. features smooth curved clamping arms to prevent puncturing wrapped bales, yet securely clamping 4' to 6' bales during transport. Available in Universal Skid Steer quick attach and Euro/Global/Alo quick attach.

The GLBS48/SSLBS48 NEW Large Square Bale Squeeze for handling large wrapped or unwrapped square 44" to 96" in length bales up to 2500 lbs. Available in Universal Skid Steer quick attach and Euro/Global/Alo quick attach.

MODEL	DESCRIPTION	WEIGHT	LIST PRICE
GLBH2072	Round Bale Squeeze with Euro/Global/Alo Quick Attach. Includes hydraulic cylinder, less hydraulic hoses	525 lbs.	\$3769
SSBH2072	Round Bale Squeeze with Universal Skid Steer Quick Attach. Includes hydraulic cylinder, less hydraulic hoses	572 lbs.	\$3819
GLBS48	Large Square Bale Squeeze with Euro/Global/Alo Quick Attach. Includes hydraulic cylinder, less hydraulic hoses	680 lbs.	\$4599
SSLBS48	Large Square Bale Squeeze with Universal Skid Steer Quick Attach. Includes hydraulic cylinder complete with hydraulic hoses and couplers	665 lbs.	\$4749

HAY HANDLING ATTACHMENTS RW Spin Off



[Click for Video](#)

Designed as an efficient hay management tool for moving and feeding round bales. The Spin Off hydraulically rotates the bale, unwinding the hay into a wind-row.

- * Eliminates wasted hay, only unroll what cattle will clean up in one hour
- * Easy operation from cab of tractor or skid steer
- * 3 Pt. hitch, front tractor loader or skid steer mount available
- * Hydraulically driven for better operator control
- * Rotates in both directions for easy feeding
- * Cushion valve in the motor provides protection for hydraulic components
- * 44" forged tapered spear
- * GPM Requirement 8-10 GPM. Min. 1500 PSI
- * 3 Pt. & skid steer models include hyd. hoses, tractor loader mount, less hyd. hoses. Less hyd. couplers

MODEL	DESCRIPTION	WEIGHT	LIST PRICE
FSO906	3 Pt Hitch Cat II/III Can be converted to Cat 1 with bushings & Cat 1 pins, (not included). Includes 2 hyd hoses, less couplers	250 lbs.	\$3249
FLSO907	Front tractor loader mount Less hyd hoses, less loader mounting brackets Optional brackets for most loader makes available	370 lbs.	\$3569
SSSO908	Skid Steer Mount Includes "Universal" skid steer quick attach bracket. Includes 2 hyd hoses (less couplers)	325 lbs.	\$3899

3 PT. MOLDBOARD PLOWS



6214



6112

as shown with optional
MP080017 depth gauge kit,
MP080018 coulter blade kit

These 3 Pt. hitch Cat.1 moldboard plows are ideal for the small acreage plowing. For sub compact and compact tractors. Made from heavy 1" x 4" steel bar with replaceable shares and moldboards. Optional depth control and coulter kits available.

MODEL	DESCRIPTION	WEIGHT	LIST PRICE
6112	One 12" Bottom Plow	290 lbs.	\$899
6114	One 14" Bottom Plow	300 lbs.	\$899
6214	Two 14" Bottom Plow	490 lbs.	\$1499
6216	Two 16" Bottom Plow	520 lbs.	\$1499

OPTIONS:

MODEL	DESCRIPTION	LIST PRICE
MP080017	Depth Gauge Kit	\$309
MP080018	Coulter Blade Kit	\$309

One Coulter Blade Kit Required per Bottom

POTATO Planter, Hiller & Digger

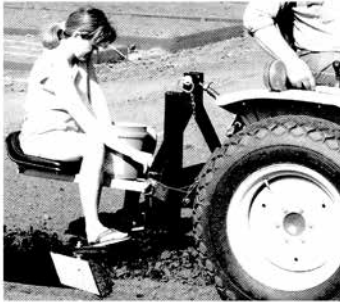

Planting



Hilling



Digging



This unique implement will do all three tasks with the greatest of ease. Attach the seat and rear cover board and plant your potatoes with ease. In mid-season bolt on the 18" sweep and hill the potatoes. At harvest time, go down the centre of the row with the sweep and watch the potatoes roll out on either side. Works like a dream.

- * **Cat. 1 3 Pt. hitch**
- * **HP Requirements: 25**

MODEL	DESCRIPTION	WEIGHT	LIST PRICE
1700166	3-in-1 Potato Planter, Hiller and Digger	170 lbs.	\$959

SINGLE SHANK FURROWER & SUB SOILER

3 Pt. Hitch



BSM100

TAR RIVER IMPLEMENTS offers a combination implement, that will dig a furrow or by changing the bottom furrow shovel to a sub soiler point can be used to fracture the soil for better air and water penetration. For tractors up to 30 HP

- * CAT. I 3 Pt. Hitch
- * Adjustable Digging Depth
- * Heavy Duty Frame
- * Shear pin protected
- * c/w Standard 14" Furrower Shovel
- * c/w Reversible Sub Soiler Point

MODEL	DESCRIPTION	WEIGHT	LIST PRICE
BSM100	Combo Furrower / Sub Soiler	88 lbs.	\$399

SUB-SOILERS

3 Pt. Hitch



These quality constructed one, two and three shank sub-soilers are constructed of 5" x 7" heavy wall steel tubing for maximum strength. The shanks are constructed of T1 steel, 1-1/4" thick with a replaceable heat treated point and are shear pin protected. Parking stands are standard equipment. Designed for 30 - 130 HP tractors.

MODEL	SHANKS	WEIGHT	FRAME LENGTH	SHANK SPACING	LIST PRICE
1S28T1	(1) 28"	243 lbs.	26"	0"	\$1829
2S2860T1	(2) 28"	609 lbs.	60"	52"	\$3359
2S2880T1	(2) 28"	655 lbs.	80"	72"	\$3489
3S3290T1	(3) 32"	1264 lbs.	90"	Adjustable	\$5879
Dble. Bar					

When using sub-soilers in rocky conditions, warranty will be considered for manufacturers defects only, not for damage from sub-terranean obstacles.

POSTHOLE DIGGERS 3 Pt. PTO & Hydraulic



500WS PHD



720 PHD

[Click for Video](#)



624H PHD



Fish Tail Point



102165
Parking stand



925 PHD



DFK50-70-90



924H PHD



824H PHD

POST HOLE DIGGERS

3 Pt. PTO & Hydraulic



- * Heavy duty tubular steel stock on yoke & booms
- * Large 2" round output shaft has two bolt auger connection
- * Shear pin protected & shielded PTO drivelines.
- * Down force kits available
- * 3 position boom adjustment on PTO models
- * 5 year limited gearbox warranty
- * Trouble free tapered roller bearings & spring loaded seals
- * Choose from a large selection of 9", 12" by 30" long, single flight and 6" to 30' x 42" long, double flight all with Fish Tail auger points
- * Parking Stands available.
- * 924HC/EURO fits directly onto ALO loaders
- * Model 624H Includes hydraulic hoses.
- * Models 724H, 824H, 924H, 924HC/ EURO. Do Not Include hydraulic hoses

MODEL	GEAR RATIO	HITCH SIZE	AUGER LENGTH	AUGER USAGE	WEIGHT	LIST PRICE
3 PT. HITCH 540 RPM PTO						
300	3:1	Cat. 0	30"	9" - 12"	149 lbs.	\$1069
500WS	3:1	Cat. 1 and 2	42"	6" - 12"	160 lbs.	\$1099
720	3.18:1	Cat. 1 and 2	42"	6" - 24"	206 lbs.	\$1399
925	4.1:1	Cat. 1 and 2	42"	6" - 30"	210 lbs.	\$1759
HYDRAULIC DRIVE, Requires 10-20 gpm @ 1500-3000 psi						
624H	3Pt. hitch	Cat 1 & 2 (inc. hyd hoses)		6" - 24"	182 lbs.	\$2599
724H		Loader (bolt-on side plate)		6" - 24"	127 lbs.	\$2389
824H		Loader (clamp-on)		6" - 24"	196 lbs.	\$2599
924H		Skid steer quick attach mount		6" - 24"	210 lbs.	\$2469
924HC		ALO loader mount		6" - 24"	220 lbs.	\$2389

AUGERS

MODEL	DESCRIPTION	WEIGHT	LIST PRICE
9SF	9" Single flight 30" long	28 lbs.	\$239
12SF	12" Single flight 30" long	32 lbs.	\$249
6HDDF	6" Double flight 42" long	32 lbs.	\$295
9HDDF	9" Double flight 42" long	47 lbs.	\$329
12HDDF	12" Double flight 42" long	54 lbs.	\$385
14HDDF	14" Double flight 42" long	76 lbs.	\$475
18HDDF	18" Double flight 42" long	98 lbs.	\$709
24HDDF	24" Double flight 42" long	128 lbs.	\$919
30HDDF	30" Double flight 42" long	190 lbs.	\$1179

OPTIONS:

MODEL	DESCRIPTION	WEIGHT	LIST PRICE
170705	12" Auger Extension (extends 42" augers to 54")	16 lbs.	\$259
DFK50	*Down force kit for model 500WS	39 lbs.	\$659
DFK70	*Down force kit for model 720, 624H	40 lbs.	\$659
DFK90	*Down force kit for model 925	42 lbs.	\$659
	*Kit contains hydraulic cylinder & hoses		
102160	Parking stand for model 300	11 lbs.	\$159
102165	Parking stand for model 500/720	12 lbs.	\$179
102170	Parking stand for model 925	13 lbs.	\$189

Weights indicated are base machine weight, not shipping weight

HYDRAULIC AUGER SYSTEMS

EP Series & PRO Series

Danuser offers planetary driven units for extreme and heavy-duty applications.

EP Series units range from 6 - 35 GPM, up to 3000 PSI and up to 3697 ft lbs of torque. Mounting is available for front-end loader, skid-steer, excavator, mini-excavator, and backhoe.

PRO Series units range from 6 - 60 GPM, up to 3000 PSI and up to 8759 ft lbs of torque. High Pressure units have up to 5000 PSI. Mounting is available for front-end loader, skid-steer, excavator, mini-excavator, and backhoe.

EP SERIES

MODEL	GPM REQUIRED	MAX AUGER	WEIGHT	LIST PRICE
DU10180	6-15 GPM	24"	138 lbs.	\$2079
DU10181	10-20 GPM	30"	139 lbs.	\$2249
DU10182	15-30 GPM	36"	140 lbs.	\$2359
DU20001	20-35 GPM	36"	140 lbs.	\$2539

Attachment Options for EP Series

MODEL	DESCRIPTION	WEIGHT	LIST PRICE
DU10488	Skid steer quick attach mount	128 lbs.	\$609
DU20652	Offset skid steer quick attach mount	72 lbs.	\$509
DU20653	Offset euro/global quick attach mount	86 lbs.	\$539
DU21354	Universal mounting kit	60 lbs.	\$429
DU10489	Bolt-on bucket mount	43 lbs.	\$369

PRO SERIES

MODEL	GPM REQUIRED	MAX AUGER	WEIGHT	LIST PRICE
DU10062	6-15 GPM	24"	154 lbs.	\$2779
DU10011	10-25 GPM	30"	156 lbs.	\$2779
DU10016	15-30 GPM	36"	157 lbs.	\$2979
DU10021	20-35 GPM	36"	159 lbs.	\$3279
DU10075	25-45 GPM	48"	226 lbs.	\$5389
DU10076	30-60 GPM	48"	235 lbs.	\$5699

High Pressure Units:

MODEL	GPM REQUIRED	MAX AUGER	WEIGHT	LIST PRICE
DU10077	25-45 GPM	48"	242 lbs.	\$6249
DU10078	30-60 GPM	48"	245 lbs.	\$6559

Attachment Options for PRO Series

MODEL	DESCRIPTION	WEIGHT	LIST PRICE
DU10499	Skid steer quick attach mount	128 lbs.	\$609
DU20656	Offset skid steer quick attach mount	72 lbs.	\$509
DU20657	Offset euro/global quick attach mount	86 lbs.	\$539
DU21354	Universal mounting kit	60 lbs.	\$429
DU10489	Bolt-on bucket mount	43 lbs.	\$369

HYDRAULICAUGER SYSTEMS



EP Series & PRO Series



EP SERIES



PRO SERIES

- * Fully sealed planetary design increases longevity and reduces maintenance
- * Robust utility style housing with integrated ears for added strength
- * Compact housing design with hoses securely routed out the top
- * Only on EP check and fill plugs are accessible without removing housing
- * Output spindles are 2" hex
- * All EP Series have 3.86:1 gearbox ratio
- * EP series has a 3 year warranty on drive unit
- * PRO Series have either 4.08:1 or 23.72:1 gearbox ratio
- * PRO series has a 5 year warranty on drive unit
- * Hose kits are 108"

CAST HEAD AUGERS - 2" HEX:

MODEL	DESCRIPTION	WEIGHT	LIST PRICE
DU10657	6" double flight 48" long	48 lbs.	\$535
DU10663	9" double flight 48" long	89 lbs.	\$829
DU10669	12" double flight 48" long	117 lbs.	\$889
DU10672	15" double flight 48" long	139 lbs.	\$1109
DU10678	18" double flight 48" long	168 lbs.	\$1309
DU10684	24" double flight 48" long	210 lbs.	\$1829

OPTIONS:

MODEL	DESCRIPTION	LIST PRICE
DU10050	1/2" hose kit with flat face ISO couplers	\$309
DU10043	1/2" hose kit with fittings, no couplers	\$209
DU10051	3/4" hose kit with flat face ISO couplers	\$429
DU10044	3/4" hose kit with fittings, no couplers	\$329
DU10910	2" hex auger extension - 12"	\$229
DU10911	2" hex auger extension - 24"	\$279

POST DRIVER

T3 Series



[Click for Video](#)

The T3 Post Driver is a small driver that delivers big time results. The top of the post is fully contained to prevent kick out and protected from damage by the strike plate. Use your tractor, skid-steer, mini-ex, loader, or backhoe to carry the weight of the driver. There are several mounting options, including an offset skid-steer quick attach which allows the operator to drive parallel to the fence line, and a bolt-on/weld-on bracket that mounts to almost any flat surface. Use down pressure from the host vehicle to drive more posts in the ground faster. The T3 Driver includes one bolt-on/weld-on bracket, hoses and flat face ISO couplers for simple plug and play operation. This is an ideal post driver for most farmers, ranchers, fencing contractors, and rental yards.

- * Drives T-Post and up to 3" OD pipe
- * 2000 lbs per stroke impact force
- * 6 strokes per second of 10 lb hammer weight
- * Optional tilt bracket allows for 20° adjustments left or right

MODEL	DESCRIPTION	WEIGHT	LIST PRICE
DU21300	T3 driver	116 lbs.	\$2479

OPTIONS:

MODEL	DESCRIPTION	WEIGHT	LIST PRICE
DU21305	T3 Driver skid-steer quick attach mount	117 lbs.	\$339
DU21355	T3 Driver skid-steer offset quick attach mount	230 lbs.	\$909
DU21303	T3 Driver euro/global offset quick attach mount	126 lbs.	\$449
DU21302	T3 mount bracket bolt-on or weld-on	4 lbs.	\$29
DU21301	Tilt bracket assembly	15 lbs.	\$209

HAMMER POST DRIVER



[Click for Video](#)

Drives fence posts, sign posts, guard rails, median dividers, tent stakes, T-posts, pipe fence, and railroad ties with ease. With this innovative design, you can achieve a full stroke with every cycle or utilize the short stroke feature to fine tune your depth. The Hammer DOES NOT operate with springs, hydraulic cylinder, or return line. Grapple option can be added to any model for a true one-person operation (does not include t-posts). The grapple option will allow the operator to grab the post off the ground, load it into the machine, and drive it in the ground without leaving the seat. CB40 Breaker Kit is available to convert any Hammer post driver into a concrete breaker.

- * **Models available for Skid-Steer, Front-End loader, and Euro/Global**
- * **Drives anything from T-Post up to railway ties**
- * **82,000 lbs per stroke impact force**
- * **40" stroke with 300 lb hammer weight at 35 strokes per minute**
- * **Optional tilt bracket allows for 20° adjustments left or right**
- * **Loaded versions include tilt, grapple and additional weight kit**

MODEL	DESCRIPTION	WEIGHT	LIST PRICE
DU21000	For skid steer	915 lbs.	\$7599
DU21001	For skid steer with grapple	955 lbs.	\$8399
DU21002	For skid steer with tilt	1005 lbs.	\$10,319
DU21003	For skid steer with tilt & grapple	1045 lbs.	\$10,999
DU21003L	For skid steer (loaded)	1245 lbs.	\$11,499
DU21009L	For loader (loaded)	1241 lbs.	\$11,699
DU21013L	For euro/global (loaded)	1241 lbs.	\$11,799

OPTIONS:

MODEL	DESCRIPTION	WEIGHT	LIST PRICE
DU21278	Concrete breaker kit	534 lbs.	\$2639
DU21163	Hammer additional weight kit	220 lbs.	\$459
DU21149	T-post adaptor	22 lbs.	\$189
DU21212	Strike plate - horseshoe	20 lbs.	\$99
DU21395	Strike plate - donut	25 lbs.	\$99

HAMMER CONCRETE BREAKER



[Click for Video](#)

The Danuser Hammer model CB40 has a 40" drop hammer design that breaks up to 9" thick reinforced concrete. This low maintenance concrete breaker achieves a full stroke with every cycle, delivering 82,000 lbs of impact force. An innovative anti-dry fire feature prevents unnecessary firing which improves the durability of the machine. This is a great product for the industrial or commercial job site. Ideal for the demolition of parking lots, foundations, flooring, sidewalks, curbs, and more!

- * Works on any Skid-Steer with 12-30 GPM
- * Smooth operation with no shock back to the vehicle
- * Less maintenance with drop hammer design
- * CB40 Breaker Kit available to convert any Hammer post driver into a concrete breaker

MODEL	DESCRIPTION	WEIGHT	LIST PRICE
DU21017	Concrete breaker for skid steer	1080 lbs.	\$8599

TRAILERS



TRM16

[Click for Video](#)



TRM160HD

Multiva is a perfect trailer for a user who values effectiveness, practicality and durability in transport. Strong frame construction, sturdy bogey and a robust body prevent the trailer from twisting during tipping. Low height, together with a wide track, makes the trailer even more stable. Wear resistant and special steel guarantee the best durability and longest lifetime. Hardox-wear resistant steels and Strenx-special steels have strength of their own class in comparison to regular (Fe52) steel.

- * Tubular bar frame
- * Standard duty trailer body floors use 5mm Strenx steel, equivalent to 10 mm Fe52 steel
- * HD trailer body floors use 6mm Hardox steel, equivalent to 18mm Fe52 steel
- * Retractable, hydraulic tailgate

MODEL	CAPACITY	VOLUME	WEIGHT	LIST
				PRICE
TRM16	16 Metric Tons	9.2 cubic meters	6945 lbs.	\$35,569
TRM160HD	16 Metric Tons	9.9 cubic meters	8488 lbs.	\$45,498

POST DRIVERS

3 Pt. Hitch



[Click for Video](#)

Installing new fencelines? Replacing old ones? **WORKSAVER** post drivers are built to last with quality features designed to improve operator convenience, versatility, production and performance in all kinds of conditions. Available with either manual adjustment crank or hydraulic cylinder controlled for post alignment

WITH MANUAL ADJUSTMENT

	HPD16	HPD22Q	HPD26Q
Maximum post size	5" x 9'	8 3/4" x 10'	11" x 10'
Impact at full stroke	32,000 lbs.	80,000 lbs.	110,000 lbs.
Impact at half stroke	16,000 lbs.	40,000 lbs.	55,000 lbs.
Hydraulic requirements	3 - 4 gpm	6 - 8 gpm	12 gpm
Minimum tractor size	20 - 22 HP	30 - 35 HP	50 - 55 HP
Hitch Type	Cat. I or II	Cat. I or II	Cat. II
Weight	600 lbs.	795 lbs.	N/A
LIST PRICE	\$4459	\$6199	N/A

WITH HYDRAULIC ADJUSTMENT

	HPD16SHC	HPD22QSHC	HPD26QSHC
Tilt Adjustment	- Front/Back 17° each way from vertical - Side/Side 20° each way from vertical		
# of Tilt Cylinders	-Two (2) 3" x 6"		
Weight	875 lbs.	1035 lbs.	1215 lbs.
LIST PRICE	\$7699	\$9449	\$11,299

POST DRIVERS

Skid Steer



Hydraulic Adjust



Manual Adjust



Installing new fence lines? Replacing old ones? Setting post for livestock pens, feedlots, vineyards, etc. save time and eliminate backbreaking labour with a **WORKSAVER** Skid steer Post Driver.

WITH MANUAL ADJUSTMENT & UNIVERSAL STYLE QUICK ATTACH BRACKETS

(SPECIAL Order, not stocked)

	HPD16MSS	HPD22QMSS
Maximum post size:	5" x 9'	8-3/4" x 10'
Impact at full stroke:	32,000 lbs.	80,000 lbs.
Impact at half stroke:	16,000 lbs.	40,000 lbs
Minimum hydraulic req.:	3 - 4 gpm	6 - 8 gpm
Mount Type	Skid Steer	Skid Steer
Weight:	678 lbs.	828 lbs.
LIST PRICE	\$5659	\$7389

WITH HYDRAULIC ADJUSTMENT & UNIVERSAL STYLE QUICK ATTACH BRACKET

(SPECIAL Order, not stocked)

	HPD16HSS	HPD22QHSS	HPD26QHSS
Tilt Adjustment	- Front/Back 17° each way from vertical - Side/Side 20° each way from vertical		
# of Tilt Cylinders	-Two (2) 3" x 6"		
Maximum post size	5" x 9'	8-3/4" x 10'	11" x 10'
Impact at full stroke	32,000 lbs.	80,000 lbs.	110,000 lbs.
Impact at half stroke	16,000 lbs.	40,000 lbs.	55,000 lbs.
Hydraulic requirements	3 - 4 gpm	6 - 8 gpm	12 gpm
Mount Type	Skid Steer	Skid Steer	Skid Steer
Weight	950 lbs.	1245 lbs.	1429 lbs.
LIST PRICE	\$9039	\$10,769	\$12,629

NOTE: Return line package required depending on make and model of skid steer (order extra), please advise model of skid steer when ordering post driver return line.

PACKERS

3 Pt.



- * Designed for 40 to 80 HP tractors
- * 3 Pt hitch Cat. I - 6', Cat. I / II - 8' & 12'
- * Heavy duty 4" square tube steel main frame
- * 16" cast iron sprocket packer wheels
- * Heavy duty 1-1/8" gang axle wth ball bearings
- * Parking stands

MODEL	DESCRIPTION	WEIGHT	LIST PRICE
BCP1816	6' working width packer	1035 lbs.	\$4199
BCP2416	8' working width packer	1300 lbs.	\$5379
BCP3616	12' working width packer	1885 lbs.	\$7929

DISC HARROWS

"THE" Series

3 Pt. Hitch



The Monroe Tufline THE series 3 Pt. hitch disc harrows are designed for 25HP to 35HP tractors. Available in 5'6", 6'4" & 6'8" cutting widths with category I 3 Pt. hitch. 3" square tube frame, 1" square high strength steel gang axles, 7 1/2" or 9" blade spacing & 18" notched disc blades. Sealed gang bearings, lever adjusting gang angles. Optional blade scrapers are available.

- * 3" Square steel tube frame
- * Cat I, 3 Pt. hitch
- * 18" Notched disc blades
- * 7 1/2" or 9" blade spacing
- * Adjustable gang angle
- * 1" High strength gang axle
- * Sealed flange mounted gang ball bearings

MODEL	# BLADES	BLADE SPACING	WIDTH	WEIGHT	LIST PRICE
1THE71618BF	16	7 1/2"	5'6"	659 lbs.	\$3049
1THE72018BF	20	7 1/2"	6'8"	732 lbs.	\$3279
1THE91618BF	16	9"	6'4"	718 lbs.	\$3159
1THE971818BF	18	9" Front 7 1/2" Rear	6'8"	736 lbs.	\$3249

OPTIONAL SCRAPER KITS

MODEL	FITS MODEL	WEIGHT	LIST PRICE
RSK716L	1THE716	65 lbs.	\$759
RSK720L	1THE720	82 lbs.	\$869
RSK916L	1THE916	72 lbs.	\$779
RSK9718L	1THE9718	80 lbs.	\$819

DISC HARROWS

"TW6" Series

Pull Type

Tufline



The TW6 Series Tandem Discs are heavy engineered discs designed for primary tillage applications. The TW6 is available in 10', 12', 13', & 15' working widths. Constructed of heavy 6" x 4" and 4" square steel frames. Blade spacing available in 9" or 10-1/2" with 24" plain or notched 6 mil disc blades on 1-1/2" cold drawn square gang axles. Gangs are mounted with triple sealed ball bearings (optional regreaseable bearings available) in a ductile cast trunnion housing with hi-strength tube style or shock flex (c-shank) gang hangers. All units offer adjustable gang cutting angle, front to rear leveling system and depth control.

- * **Heavy 6" x 4" and 4" Square Steel Frame**
- * **Dual Wheel Carriage with 4 – 9.5L x 15 6 Ply Implement tires**
- * **Front to Rear Leveling System**
- * **Depth Control System**
- * **Adjustable Gang Cutting Angle**
- * **1-1/2" Square cold Drawn Steel Gang Axle**
- * **9" or 10-1/2" Blade Spacing**
- * **24" 6 mil Plain or Notched Disc Blades (Customer Choice)**
- * **Triple Sealed Trunnion Mount Gang Ball Bearings**
- * **Available with Tube Style or Shock Flex Gang Hangers**
- * **Includes Implement Tongue Jack, Safety Chain,**
- * **Includes 4"X 8" Hydraulic Cylinder, Set of Hydraulic Hoses**
- * **Options Available**
 - Regreaseable Gang Ball Bearings**
 - Heavy Adjustable Blade Scrapers**

DISC HARROWS

"TW6" Series

Pull Type



9" SPACING

MODEL	BLADES	# OF BRGS	WIDTH	TUBE WT. (LBS)	TUBE LIST	SHOCK FLEX WT. (LBS)	SHOCK FLEX LIST
TW692824	(28) 24"	8	10' 6"	4401 lbs	\$18,959	4869 lbs	\$21,329
TW693224	(32) 24"	8	12'	4794 lbs	\$20,699	5212 lbs	\$23,069
TW693624	(36) 24"	12	13' 4"	5158 lbs	\$22,859	5576 lbs	\$26,339
TW694024	(40) 24"	12	15'	5539 lbs	\$24,689	5975 lbs	\$28,229

10-1/2" SPACING

MODEL	BLADES	# OF BRGS	WIDTH	TUBE WT. (LBS)	TUBE LIST	SHOCK FLEX WT. (LBS)	SHOCK FLEX LIST
TW6102424	(22) 24"	8	10' 6"	4279 lbs	\$17,849	4883 lbs	\$20,199
TW6102824	(28) 24"	8	12'	4570 lbs	\$18,959	4886 lbs	\$21,319
TW6103224	(32) 24"	12	13' 4"	4970 lbs	\$21,999	5324 lbs	\$25,539
TW6103624	(36) 24"	12	15'	5319 lbs	\$23,539	5737 lbs	\$27,099

Add "SF" to model # when ordering disc equipped with shock flex gang hangers

TW6 SERIES SCRAPER KITS

9" SPACING

MODEL	USED ON	WEIGHT (LBS.)	LIST PRICE
SK928/6	TW6928	320	\$1859
SK932/6	TW6935	353	\$1969
SK936/6	TW6936	441	\$2119
SK940/6	TW6940	479	\$2269

10-1/2" SPACING

MODEL	USED ON	WEIGHT (LBS.)	LIST PRICE
SK1024/6	TW61024	298	\$1599
SK1028/6	TW61028	326	\$1789
SK1032/6	TW61032	406	\$1959
SK1036/6	TW61036	448	\$2129

TW6 SERIES OPTIONS:

MODEL	DESCRIPTION	LIST PRICE
T703-18	(Pair) Outrigger kit (Furrow Filler)	\$389
11476	Balk breaker with point	\$379
13188	Regreasable gang ball bearings	\$50

Weights indicated are base machine weight, not shipping weight

OFFSET DISC "42" Series



- * Includes 4" x 8" Hydraulic Cylinder with hydraulic hoses (less coupler plugs)
- * Implement Tongue Jack, Safety Chain, SMV Sign
- * Standard with Notched Disc Blades
- * HP Requirements: 60-120 (Approx. 10 HP per Ft.)
- * Tongue and yoke system for side draft
- * Gang angles adjust by turnbuckles
- * Triple sealed ball bearings in trunnion mount
- * Dual wheels on all models includes 9.5L x 15 6 ply implement tires
- * 24" and 26" disc blades - 1/4" thick
- * Shock flex gang hangers for rocky soil conditions
- * 6" x 4" heavy wall tube frame
- * 1-1/2" RC square cold drawn axle
- * Front and rear levelling system

OPTIONAL EQUIPMENT

- * Blade scrapers, Plain (Smooth) Blades, Regreasable Gang Bearings, Furrow Filler Kit (see page 151 OPTIONS)

9" SPACING

MODEL	BLADES	# OF BRGS	WIDTH	SHOCK FLEX WT. (LBS)	SHOCK FLEX LIST
42/91824SF	(18) 24"	8	6' 8"	3907	\$19,479
42/91826SF	(18) 26"	8	6' 8"	4038	\$20,129
42/92024SF	(20) 24"	8	7' 8"	4000	\$20,049
42/92026SF	(20) 26"	8	7' 8"	4166	\$20,749
42/92224SF	(22) 24"	8	8' 4"	4250	\$20,599
42/92226SF	(22) 26"	8	8' 4"	4396	\$21,399
42/92424SF	(24) 24"	8	9'	4540	\$21,089
42/92426SF	(24) 26"	8	9'	4672	\$21,959
42/92824SF	(28) 24"	12	10' 4"	4868	\$23,199
42/92826SF	(28) 26"	12	10' 4"	5047	\$23,959
42/93224SF	(32) 24"	12	12' 3"	5161	\$25,789
42/93226SF	(32) 26"	12	12' 3"	5344	\$26,799
42/93624SF	(36) 24"	14	13' 3"	5311	\$28,049
42/93626SF	(36) 26"	14	13' 3"	5655	\$28,799

OFFSET DISC

"42" Series



10-1/2" SPACING

MODEL	BLADES	NO. OF BRGS.	WIDTH OF CUT	SHOCK FLEX WGT. (LBS.)	SHOCK FLEX LIST
42/101824SF	(18) 24"	8	8'	4002	\$19,699
42/101826SF	(18) 26"	8	8'	4010	\$20,349
42/102024SF	(20) 24"	8	9'	4228	\$20,129
42/102026SF	(20) 26"	8	9'	4360	\$20,799
42/102224SF	(22) 24"	8	9' 10"	4394	\$20,679
42/102226SF	(22) 26"	8	9' 10"	4526	\$21,479
42/102424SF	(24) 24"	8	10' 6"	4649	\$21,619
42/102426SF	(24) 26"	8	10' 6"	4807	\$22,489
42/102824SF	(28) 24"	12	12'	5164	\$25,339
42/102826SF	(28) 26"	12	12'	5314	\$26,349
42/103224SF	(32) 24"	12	13' 9"	5278	\$25,999
42/103226SF	(32) 26"	12	13' 9"	5500	\$27,169

42 Series SCRAPER KITS

9" SPACING

MODEL	USED ON	WEIGHT (LBS.)	LIST PRICE
OSK42/918	42/918	276	\$1159
OSK42/920	42/920	294	\$1229
OSK42/922	42/922	325	\$1359
OSK42/924	42/924	359	\$1419
OSK42/928	42/928	460	\$1699
OSK42/932	42/932	527	\$1899
OSK42/936	42/936	580	\$2059

10-1/2" SPACING

MODEL	USED ON	WEIGHT (LBS.)	LIST PRICE
OSK42/1018	42/1018	277	\$1219
OSK42/1020	42/1020	303	\$1299
OSK42/1022	42/1022	330	\$1379
OSK42/1024	42/1024	352	\$1439
OSK42/1028	42/1028	410	\$1769
OSK42/1032	42/1032	527	\$1919

42 SERIES OPTIONS:

MODEL	DESCRIPTION	LIST PRICE
T703-1/2-20	Furrow Filler	\$225
13188	Additional charge for regreasable gang brgs. 1-1/2"	\$50

TO PRICE AN OFFSET DISC MAKE SURE YOU HAVE PRICED:

1. Scraper kit (If Required)
2. Any applicable options from the option list
3. Remember your spacing - 9" or 10-1/2" available
4. Order blades plain, notched, or a combination

TRACTOR CANOPIES JUNIOR

BARE-Co



B3580 Shown



B3581 Shown

The **BARE-Co** junior canopy is moulded from virtually indestructible flexible U.V. stabilized polyethylene. The canopy is 34" wide x 47" long and is designed moulded to hug modern hoop type ROPS frames. Available in standard colours, universal mounting kit to fit most types of ROPS frames, order extra.

MODEL	DESCRIPTION	WEIGHT	PRICE
B2581	White Canopy	20 lbs.	\$399
B2582	Green Canopy	20 lbs.	\$399
B2583	Orange Canopy	20 lbs.	\$399
B2584	Blue Canopy	20 lbs.	\$399
B2585	Red Canopy	20 lbs.	\$399
B2586	Yellow Canopy	20 lbs.	\$399
B3580	Mounting Kit Mounts canopy to HOOP, CURVED or SQUARE TOP Both rigid or folding up to 30" wide with leg thickness up to 3-3/16" x 2"	17 lbs.	\$180
B3581	Mounting Kit Mounts the canopy OVERWIDTH ROPS frames with a width of more than 30" wide, with a leg thickness from 2" x 2" to 2" x 4"	13 lbs.	\$140

TRACTOR CANOPIES STANDARD

BARE-Co



B3600 Shown



B2565 Shown

The **BARE-Co** standard canopy is moulded from virtually indestructible flexible U.V. stabilized polyethylene. The canopy is 45" wide x 60" long and is designed moulded to hug modern hoop type ROPS frames. Available in standard colours, universal mounting kit to fit most types of ROPS frames, order extra.

MODEL	DESCRIPTION	WEIGHT	PRICE
B2570	White Canopy	29 lbs.	\$489
B2571	Green Canopy	29 lbs.	\$489
B2572	Orange Canopy	29 lbs.	\$489
B2573	Blue Canopy	29 lbs.	\$489
B2580	Red Canopy	29 lbs.	\$489
B3600	Mounting Bracket Mounts the canopy to any folding or rigid hoop type ROPS frame up to 41-1/2" wide, with leg thickness up to 3-3/16" x 2"	17 lbs.	\$195
B2565	Mounting Bracket Mounts the canopy to overwidth ROPS frames, crossbar or leg width more than 41-1/2", leg thickness from 2" x 2" to 2" x 4"	13 lbs.	\$155
B4620	Mounting Bracket Mounts the canopy to ROPS frames up to 41-1/2" wide with leg thicknesses of 4" x 4", 5" x 2" or 6" x 2"	21 lbs.	\$225

QUICK HITCHES

SPEECO quick hitches are built for fast, safe and easy connection and disconnection of 3 Pt. hitch implements. The SPEECO quick hitches fit most CAT. I, II & III 3 Pt. Hitch tractors and implements.

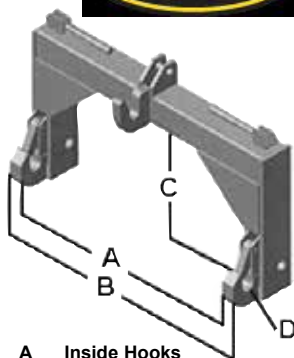

MODEL	QUICK HITCH SPECIFICATIONS		
	A	B	C
QH10178	25.75"	29.50"	14.50" - 17.25"
QH102	32.75"	36.25"	14.88"
QH107HD	32.50	37.75"	14.88"
QH1023	38.25"	43.15"	18.88"
QH103	38.25"	43.50"	18.88"
QH106N	32.63"	37.00"	19.00"

- A Inside Hooks
- B Outside Hooks
- C Centerline Distance of lower pin to upper pin
- D Pocket sized for 1-7/16" pins or bushings

- * High strength tubing for torsional strength
- * Over-center spring loaded latch mechanism provides positive lock yet easy equipment release
- * Solid frame cut parts for long life
- * Reinforced at known wear points
- * Non-rotating adapter bushings for wear resistance
- * Rubber handle grips on latch handles
- * Tapered top hitch point bracket for easy hook-up
- * QH102, QH107HD includes one set (pair) of adapter bushings

MODEL	DESCRIPTION	WEIGHT	LIST PRICE
QH10178	Cat. 1 (up to 50 HP)	76 lbs.	\$379
QH102	Cat. 2 (up to 100 HP)	134 lbs.	\$579
QH107HD	Cat. 2 HD (up to 150 HP)	160 lbs.	\$799
QH1023	Cat. 2 to Cat. 3 Allows use of Cat. 3 implements on tractors with Cat. 2, 3 Pt hitch	176 lbs.	\$989
QH103	Cat. 3 (up to 225 HP)	233 lbs.	\$929
QH106N	Cat. 3 Narrow (up to 225 HP)	183 lbs.	\$929

HYDRAULIC TOP LINK



TLC3110

MODEL	DESCRIPTION	WEIGHT	LIST PRICE
TLC2708	Cat. I, 2" bore x 8" stroke 1-1/8" dia. shaft	18 lbs.	\$309
TLC3110	Cat. II, 3" bore x 10" stroke 1-1/4" dia. shaft	26 lbs.	\$399

WELD-ON ATTACHMENT BRACKETS



Easily convert your bucket or other attachments to be used on your skid steer or Euro/Global/Alo loader with a Weld-on plate.

MODEL	DESCRIPTION	PRICE
832540	"Universal" Skid Steer Quick Attach, 1/4" material plate 46 lbs	\$219



MODEL	DESCRIPTION	PRICE
832790	"Universal" HD Skid Steer Quick Attach, 3/8" material plate 96 lbs	\$375



MODEL	DESCRIPTION	PRICE
ALO1	Euro/Global/Alo Two (2) piece weld-on brackets 36 lbs	\$165



Left Hand



Right Hand

MODEL	DESCRIPTION	PRICE
832625	Euro/Global/Alo HD 5/16" material plate 95 lbs	\$499

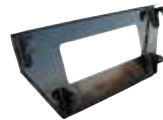

MODEL	DESCRIPTION	PRICE
835060	John Deere 300/400 Series Loaders, Weld-on plate 70 lbs	\$349



MODEL	DESCRIPTION	PRICE
835065	John Deere 400 - 500 Series Loaders, Weld-on plate 83 lbs	\$385



LOADER ADAPTOR BRACKETS



WORKSAVER elevates your tractor's productivity by converting it's loader (depending on make & model) to either "Universal" Skid Steer quick attach or the EURO/GLOBAL/ALO standard quick attach system. Worksaver adapter brackets feature all welded frames for durability, plated latch components for long service life.

Euro/Global/Alo to Skid Steer

MODEL	DESCRIPTION	PRICE
832550	Interfaces with agricultural loaders that use the Euro/Global/Alo attaching system to allow the use of skid steer attachments, 110 lbs	\$999



Skid Steer to Euro/Global/Alo

MODEL	DESCRIPTION	PRICE
835020	Interfaces with skid steer or agricultural loaders that use the "Universal" skid steer attaching system Attachments that mount to Euro/Global/Alo tool carrier, 145 lbs	\$1499



3 Pt. Hitch to "Universal" Skid Steer

MODEL	DESCRIPTION	PRICE
835080	Allows mounting skid steer type attachments to their tractors Will fit both CAT I or II hitches, 145 lbs	\$949



Skid Steer CAT I, 3 Pt. Quick Hitch

MODEL	DESCRIPTION	PRICE
835095	Allows the operator to use CAT 1, 3 Pt hitch non PTO powered implements on a skid steer with "Universal" skid steer quick attach, 148 lbs	\$949



Worksaver has many more loader adapters available, for IH 2250 & 2255 loaders, Case IH L160/LX114/ LX116/LX118 series loaders, John Deere 48/58 series, 145/146/148/158 series, 240/245/260/265 series, 300/400/500 series, 600/700 series loaders, Kubota LA350/401/452/852/1251, 1301, 1601 series loaders, Massey Ferguson 232/236/238/246/832/838/848/938/948/1036/1048 series loaders, New Holland 21 09/7108/7109/7209/7210/7308/7309/7310/7410 series, 14LA/15LA/16LA/17LA/18LA series loaders. Check with your local dealer for pricing and availability on these and many more.

H&S

H & S Manufacturing Company Marshfield Wisconsin

H & S Mfg. was founded in 1967 by Mr. Laurie Heikenen and remains a family owned business today. Manufacturers of quality agricultural equipment, forage boxes, manure spreaders and hay equipment including hay rakes and windrow mergers. Contact your local H & S dealer for your equipment needs or call 519-461-1499 for the dealer in your area.



ROTARY BROOMS

3 Pt. HITCH PTO



[Click for Video](#)

The WORKSAVER 3 Pt. hitch 540 RPM PTO Rotary Broom mounts to any tractor with 540 RPM PTO. Keep your tractor and sweeper busy all year sweeping snow, dirt, thatch, leaves and other debris. Sweeps forward and can wind-row debris, to the front, right or left. If you reverse broom rotation, pulling action cleans thatch with out damaging grass. Mechanical brush drive, with optional manual angle, 30 degrees right or left, or optional hydraulic angle available. Height adjustment chains maintains even operating position. 32" diameter broom is available in poly, or combo 50/50 poly/wire. A double gearbox drive is used for smooth power transmission and low maintenance. Top "T-Shaft" gearbox allows for easy reversal of brush rotation.

- * **Cat. 1, 3 Pt. hitch**
- * **540 RPM PTO**
- * **Optional Manual or hydraulic angle**
30 degrees right or left
- * **Height adjustment chains**
- * **32" diameter brush**
- * **Available in Poly, or 50/50 Poly/Wire brush**
- * **Double gearbox drive**
- * **Top "T-Shaft" gearbox allows easy reversal of brush rotation**

MODEL	DESCRIPTION	WEIGHT (LBS.)	LIST PRICE
RMB325P	5' Wide rotary broom with poly brush	640 lbs.	\$7719
RMB325PW	5' Wide rotary broom with poly/wire brush	640 lbs.	\$7719
RMB326P	6' Wide rotary broom with poly brush	740 lbs.	\$8089
RMB326PW	6' Wide rotary broom with poly/wire brush	740 lbs.	\$8089
RMB327P	7' Wide rotary broom with poly brush	840 lbs.	\$8819
RMB327PW	7' Wide rotary broom with poly/wire brush	840 lbs.	\$8819

OPTIONS:

MODEL	DESCRIPTION	LIST PRICE
610702	Manual Angle Kit	\$205
610703	Hydraulic Angle Kit with hoses	\$639

ROTARY BROOMS SKID STEER MOUNT



[Click for Video](#)

The WORKSAVER skid steer hydraulically driven rotary broom fits any make and model of skid steer with universal skid steer quick attach mounting. Hydraulic motor rated @ 16GPM continuous operation for maximum brush speed. Optional manual or hydraulic angling kit available. All hydraulic hoses sheathed and routed through integral loops for maximum protection. Flat-faced "connect under pressure" hydraulic couplers standard

- * Universal skid steer quick attach mounting
- * 16 GPM hydraulic motor
- * 4.36 / 1 chain drive ratio to broom for excellent torque
- * Heavy duty #60 drive roller chain
- * Parking stands
- * Step-through mount design for easy in/out of skid steer cab
- * Greaseable pivot points for long life
- * 32" diameter poly or poly/wire brush
- * Optional manual or hydraulic angle adjustment kit available

MODEL	DESCRIPTION	WEIGHT	PRICE
SSMB325P	5'/60" Wide Rotary Broom with Poly Brush	720 lbs.	\$8259
SSMB325PW	5'/60" Wide Rotary Broom with Poly/Wire Brush	714 lbs.	\$8259
SSMB326P	6'/72" Wide Rotary Broom with Poly Brush	780 lbs.	\$8799
SSMB326PW	6'/72" Wide Rotary Broom with Poly/Wire Brush	774 lbs.	\$8799
SSMB327P	7'/84" Wide Rotary Broom with Poly Brush	840 lbs.	\$9699
SSMB327PW	7'/84" Wide Rotary Broom with Poly/Wire Brush	833 lbs.	\$9699

OPTIONS:

	DESCRIPTION	LIST PRICE
610702	Manual Angle Adjustment Kit	\$205
610703	Hydraulic Angle Adjustment Kit	\$639
610940	inc'ds hyd. cylinder & hoses, less tips Hydraulic Angle Adjustment Kit with Electric Hydraulic Solenoid control. For skid steer rotary Brooms used on units equipped with only one set of remotes, inc'ds hyd. cylinder, hoses, valve, & flat faced couplers, Factory Installed	\$2099

Weights indicated are base machine weight, not shipping weight

WWW.FARMFLEET.COM

23703 Wellburn Rd.
St. Marys, ON N4X 1C6
Tel: 519-461-1499
Fax: 519-461-1599

839 McLellans Brook Rd.
New Glasgow, NS B2H 5C5
Tel: 902-755-0858
Fax: 902-755-2362

Email: sales@farmfleet.com

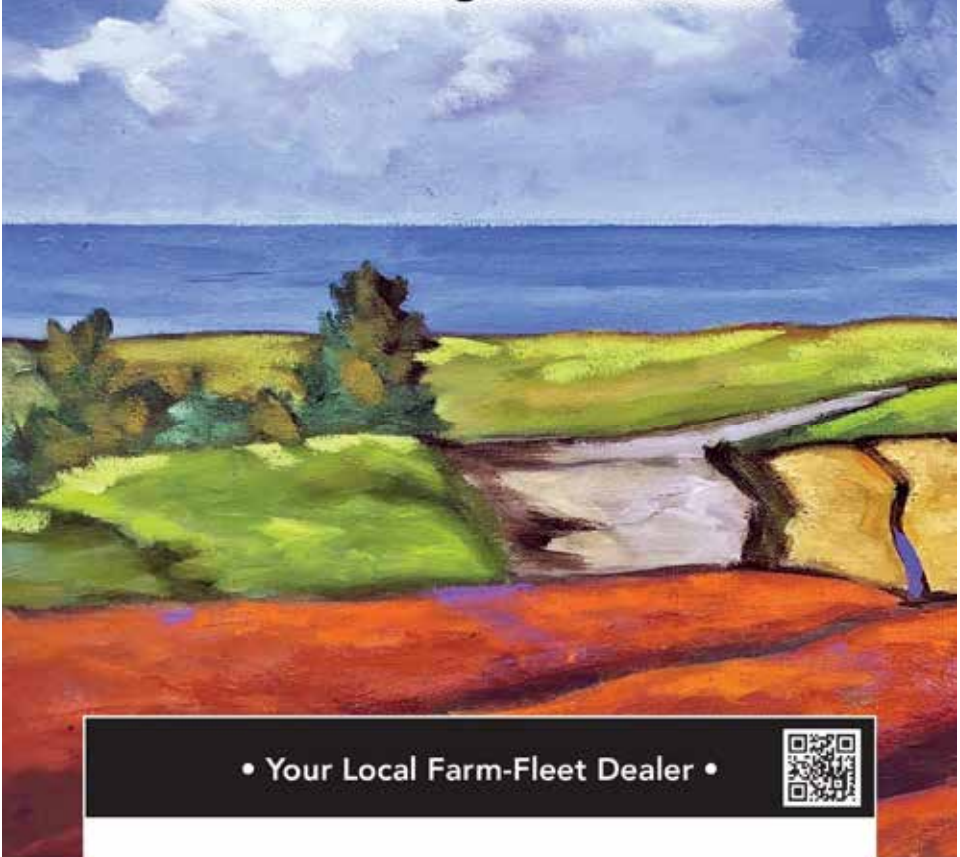

• Your Local Farm-Fleet Dealer •

