



**AMAZONE**

# The products



# GO

## AMAZONE

## Soil tillage

## Sowing technology

|                                     |    |
|-------------------------------------|----|
| 3C Cost Cutting Concept             | 5  |
| Full speed ahead                    | 6  |
| The strong trademark for innovation | 8  |
| Internationally successful          | 10 |
| AMAZONE service                     | 12 |
| AMAZONE Fertiliser Advisory Service | 14 |
| AMAZONE ACTIVE                      | 15 |
| IT farming                          | 16 |
| AMATRON 3 – One for all             | 18 |
| CCI terminal                        | 20 |
| AMAPAD                              | 21 |

|  |    |
|--|----|
| <b>Passive soil tillage</b>                    |    |
| <b>Cayros</b> mounted reversible plough        | 24 |
| <b>Cayron</b> mounted reversible plough        | 26 |
| <b>Catros</b> compact disc harrow              | 28 |
| <b>Certos</b> heavy compact disc harrow        | 33 |
| <b>Cenius</b> mulch cultivator                 | 34 |
| <b>Ceus</b> disc harrow cultivator combination | 38 |
| <b>Following rollers</b>                       | 39 |
| <b>XTender</b> and <b>XTender-T</b> rear tank  | 40 |
| <b>AW</b> land roller                          | 41 |
| <b>Active soil tillage</b>                     |    |
| <b>KE</b> rotary harrow                        | 42 |
| <b>KX</b> and <b>KG</b> rotary cultivators     | 44 |

|   |    |
|---|----|
| <b>Sowing technology</b>  |    |
| <b>D9</b> mounted gravity seed drill                                    | 48 |
| <b>AD</b> pack top gravity seed drill                                   | 49 |
| <b>Cataya</b><br>conventional seed drill combinations                   | 50 |
| <b>AD-P</b> pneumatic pack top seed drill                               | 52 |
| <b>Centaya Super</b> seed drill combination                             | 54 |
| <b>Avant</b> mounted sowing combination<br>with front tank              | 56 |
| <b>Cirrus</b> trailed sowing combination                                | 57 |
| <b>Citan</b> large area seed drill                                      | 60 |
| <b>Cayena</b> tine coulter seed drill                                   | 62 |
| <b>Condor</b> tine coulter seed drill                                   | 63 |
| <b>Primera DMC</b> large area seed drill                                | 64 |
| <b>KR 9002/12002</b> trailed carrier system                             | 66 |
| <b>GreenDrill</b> Pack Top seeder box<br>for fine seeds and catch crops | 67 |
| <b>Precision seeding technology</b>                                     |    |
| <b>ED</b> precision air seeder  | 68 |
| <b>EDX</b> high speed precision air seeder                              | 70 |



# for Innovation

## Fertilisation technology

|  |    |
|--|----|
| <b>ZA-X Perfect</b> mounted spreader     | 74 |
| <b>ZA-M</b> mounted spreader             | 75 |
| <b>ZA-V</b> mounted spreader             | 76 |
| <b>ZA-TS</b> mounted spreader            | 80 |
| <b>ZG-TS</b> trailed fertiliser spreader | 82 |
| <b>ZG-B</b> bulk fertiliser spreader     | 83 |

## Plant protection systems

|  |    |
|--|----|
| <b>UF</b> mounted sprayer  | 86 |
| <b>FT 1001</b> front tank  | 87 |
| <b>UX</b> trailed sprayer  | 88 |
| <b>ContourControl</b> and <b>SwingStop</b>                           | 91 |
| <b>UX 11200</b> trailed sprayer                                      | 92 |
| <b>UG</b> trailed sprayer  | 93 |
| <b>Pantera</b> self-propelled sprayer                                | 94 |
| <b>AmaSwitch</b> and <b>AmaSelect</b><br>individual nozzle switching | 96 |

## Groundcare technology

|   |     |
|---|-----|
| <b>Groundkeeper</b><br>multi-functional mower/collector               | 100 |
| <b>Profihopper</b><br>self-propelled mower/collector                  | 101 |
| <b>Landscape maintenance combination</b><br><b>GNK</b> and <b>GBK</b> | 102 |
| <b>E+S, EK-S</b> and <b>ZA-XS</b> spreaders                           | 103 |
| Overview of AMAZONE range   | 106 |











## 3C Cost Cutting Concept – “Higher work rates with less input!”

For a business to succeed, it is crucial to increase profits and to reduce the operational and labour costs yet further. AMAZONE has, based on long-term field trials and through discussions with farmers, science and advisors, developed the 3C – Cost Cutting Concept. With “5% more profit from 50% less fuel and 60% less working time” this banner headline shows the potential that the 3C-Concept offers.

The individual farm manager – who has expert local knowledge over the complete business – is best placed to choose the optimum solution for their own farm.

Any system, obviously, has to take into account the local farming structure so that the techniques are optimised to suit the region but achievement of these savings is made possible, by a combination of all the procedural steps from stubble chitting and primary soil tillage through to seed sowing techniques and also from fertilisation through to crop protection application techniques. We can offer you the right machine for all areas of “Intelligent Crop Production”.

The aim as always, with regard to sustainability, is about securing the long-term existence of your business. Therefore, we continue to make every effort, on basis of the 3C-Concept, to fulfil our motto that we have stood for over the last 130 years:

**“AMAZONE machinery generates profit and saves the environment”.**

Dr. Justus Dreyer  
Manager

Christian Dreyer  
Manager



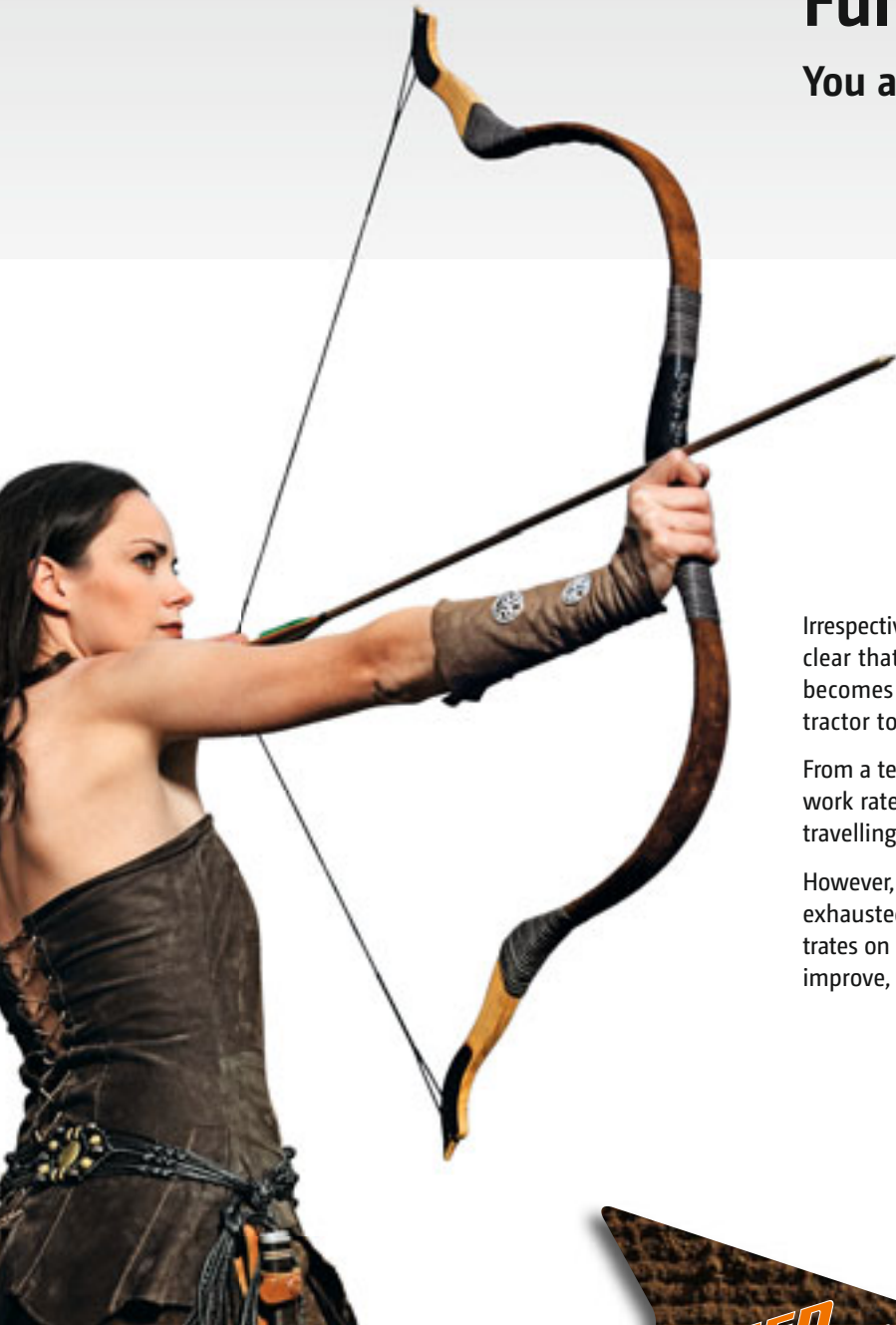

# Full speed ahead

You and us – swift as an arrow!

Irrespective as to what work is on the agenda, it becomes increasingly clear that the time window needed to get through that field work becomes even tighter and so it is necessary for any farmer or contractor to gain more and more output in a shorter time.

From a technical point of view, there are two alternatives for higher work rates in a shorter period. Increasing the working width, or travelling at “full speed ahead”.

However, the possibility to further increase working width is largely exhausted. Therefore AMAZONE research and development concentrates on the “full speed” aspect. At the same time we want to further improve, not only the quality of work, but also operational comfort.



In other words that means: AMAZONE will continue to help you, within the framework of the 3C farming concept, to achieve “higher work rates with less input”.







# The strong trademark for innovation

# GO

## AMAZONE – the family business that is full of ideas



AMAZONEN-WERKE was founded in 1883 by Heinrich Dreyer, although the Dreyer family were involved in the manufacture of agricultural machinery long before this time.

Today AMAZONEN-WERKE is still owned by the Dreyer Family, now in its fourth generation.

Since its establishment, AMAZONE has continually produced outstanding, pioneering innovations. The total of 32 gold and silver medals from the AGRITECHNICA Show is ample proof of the strong drive for innovation within the AMAZONE group.



1883

today

## AMAZONE – examples of a successful story



**1917**  
First auger type fertiliser spreader



**1948**  
First seed drill



**1958**  
First mounted twin-disc fertiliser spreader



**1967**  
First modern sowing combination with reciprocating power harrow



# for Innovation

## AMAZONE – Intelligent crop production

The AMAZONE Group sees itself as an international system supplier for “intelligent crop production”, providing new, innovative machinery,

service and advice concepts concentrated on the specialist areas of fertilisation, crop protection, soil tillage and sowing technology.



**Fertilisation technology:** e.g. ZA-TS spreader



**Plant protection systems:** e.g. Pantera self-propelled sprayer



**Soil tillage technology:** e.g. Cenius-2TX mulch cultivator



**Sowing technology:** e.g. Cirrus large area sowing combination



**1979**  
First rotary cultivator



**1992**  
First fertiliser test laboratory and fertiliser advisory service



**1995**  
Entry into GPS and sensor technology

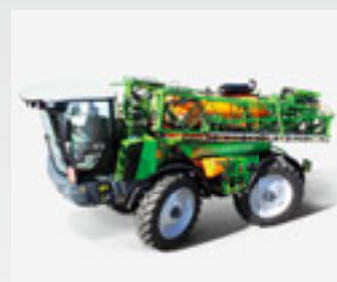

**2010**  
Pantera – first self-propelled equipment

# Internationally successful

“We have to go out into the world” (quote Heinrich Dreyer, 1906)



**Since 1958**  
Production site in Hude, near Oldenburg



**Since 1970**  
Production site in Forbach, France



**Since 1998**  
Takeover of production site BBG Leipzig

## Worldwide sales network

With an efficient sales and service network the AMAZONE group are present worldwide, co-operating with more than 70 importers.

At present, exports account for over 80% of the total turnover.

As well as constantly looking after the European markets, the AMAZONE group is always looking to open up new markets, for example in Africa or Asia.

In Germany and Austria 22 company representatives and 7 sales promotion specialists maintain a close, engaged team offering trusted advice in the home markets.





Headquarters in Gaste near Osnabrück

## AMAZONE – a fair partner for more than 130 years

The AMAZONE Group is an international manufacturer with over 1800 employees:

- Agricultural machinery for soil tillage, sowing, fertilisation and crop protection
- Municipal machinery for lawn maintenance and winter service

With high quality outstanding products, competitive prices and a comprehensive after-sales service, AMAZONE is the ideal partner for farmers, contractors and dealers alike.



Since 2016  
Production site in Mosonmagyaróvár, Hungary



Since 2006  
Production site in Samara, Russia



Since 2007  
Production site in Leeden near Osnabrück



Since 2008  
Production site at Altmoorhausen near Oldenburg

Today the AMAZONE group owns production sites in Germany, France, Russia and Hungary employing more than 1800 people.

In the countries Great Britain, France, Russia, Hungary, Kazakhstan, Ukraine, China and Canada, AMAZONE machinery is sold via factory-owned subsidiaries.



Since 2008  
Sales subsidiary at Auneau, France



# AMAZONE service – Always in your vicinity

Your satisfaction is our challenge



## AMAZONE SmartService 4.0

In the world of evermore complex machine design, AMAZONE, via SmartService 4.0, is utilising the technology made possible by digital VR and AR technologies to further enhance its learning, training and repair processes in the sector of technical customer service as well as assisting its customers in carrying out routine maintenance work. This realisation is carried out through training using Virtual Reality (VR) and via the possibility of real time communication with service specialists from AMAZONE along with the creation and provision of learning contents by utilising Augmented Reality (AR).





## The satisfaction of our customers is the most important objective

For this we rely on our competent sales partners. Also for service queries they are the reliable contact partner for farmers and contractors. Due to continuous training, our sales partners and service technicians are always up to date when it comes to looking after the state of the art technology.

## We provide you with a first class spare parts service

The basis for our worldwide spare parts logistics is the central spare parts depot at our headquarters in Hasbergen-Gaste. This ensures the maximum availability of spare parts, even for older machines.

Parts which are available in our central spare parts depot in Hasbergen-Gaste, ordered up until 17.00 hours, are dispatched the same day. 34,000 different line items of spare parts and wearing metal are located in our highly modern store and daily, up to 800 orders are sent to our customers.

## Better to choose the original right from the start

Your equipment is exposed to extreme demands. The quality of AMAZONE spare parts and wearing metal offers you the reliability and safety you need for efficient soil tillage, precise sowing, professional fertilisation and successful crop protection.

Only original spare parts and wearing metal are perfectly matched to AMAZONE machinery in their functionality and durability. This ensures the optimum operational performance. Original parts at a fair price pay off in the end.

Therefore decide on the original!

The advantages of original spare parts and wearing metal

- ⊕ Quality and reliability
- ⊕ Innovation and efficiency
- ⊕ Immediate availability
- ⊕ Higher resale value of the used machine

## AMAZONE “E-Learning” – driver training via the PC

With the Internet tool “E-Learning”, AMAZONE has supplemented the services offered on its homepage at [www.amazone.de/e-learning](http://www.amazone.de/e-learning) by a very useful function. “E-Learning” offers interactive driver training, which enables the operator to practice the operation of complex machinery on their own, and outside normal working hours, through being trained interactively on-line or off-line via a PC or tablet. On the one hand, a new operator can follow the modules and get acquainted with the machine beforehand, whereas, on the other hand, experienced drivers can refresh their knowledge enabling them to be able to increase the efficiency of their machines.



**Choose the Original  
Choose Success!**  
VDMA campaign:  
Pro-Original

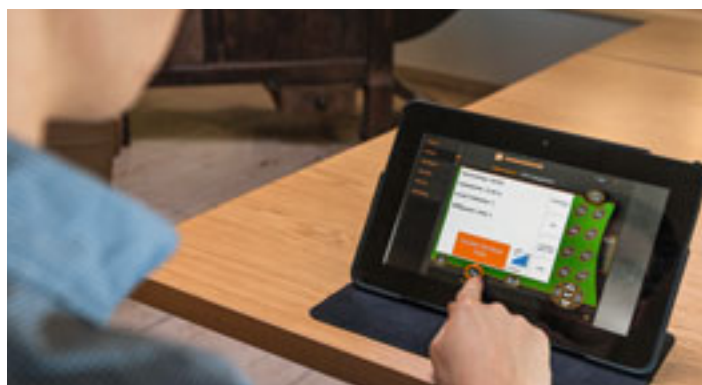



# AMAZONE Fertiliser Advisory Service

Exemplary!

## Fertiliser service – How to contact us:

Internet: [www.amazone.de](http://www.amazone.de)  
E-mail: [duengeservice@amazone.de](mailto:duengeservice@amazone.de)  
Phone: +49 (0)5405 501-111  
Fax: +49 (0)5405 501-374

## Only correctly spread fertiliser is worth its weight in gold!

The AMAZONE Fertiliser Advisory Service closely co-operates with renowned manufacturers of spreading materials – worldwide – in order to provide you with the best setting values as fast as possible. AMAZONE has a worldwide reputation for precise setting charts.



## Fertiliser service on the Internet: [www.amazone.de](http://www.amazone.de)

On the internet, at [www.amazone.de](http://www.amazone.de), one can download from the on-line data base, around the clock and free of charge, the settings for both the lateral distribution and the application rate settings for all AMAZONE fertiliser spreaders. Simply choose the machine type and the material to be spread.

Now also as App for Android Smartphones or iOS devices.



Android handsets



iOS devices



Our FertiliserService App has already been downloaded more than 50,000 times. A service that no other fertiliser spreader manufacturer offers.

AMAZONE FertiliserService from the spreader test hall



# AMAZONE ACTIVE

## More knowledge

Under the framework of our ACTIVE Programme, we host seminars based around the topic of “Intelligent Crop Production” at our ACTIVE Centres in, for example, Gaste, Hude, Leipzig, Harworth, Auneau, Samara and Tianjin.

In addition we organise topical meetings at the sites of AMAZONE field trials in various regions of Germany.



### www.amazone.de – on-line service

All around the globe, available 24 hours per day, 7 days a week and 365 days a year: Information on spare parts, operating manuals, leaflets, videos etc.

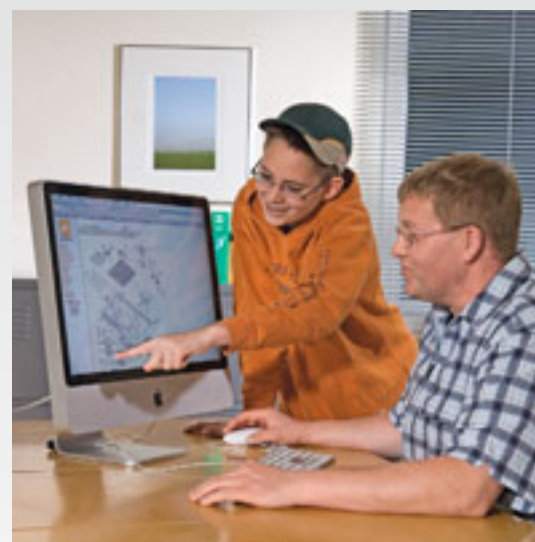





# IT Farming

**GPS (Global Positioning System) Precision Farming**

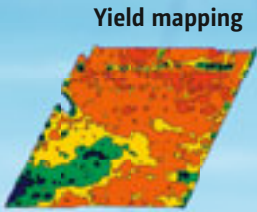

**Reference station for RTK accuracy**

Terminal for nitrogen sensor  
AMAPAD ISOBUS terminal

**ISOBUS**

Nitrogen sensor

Electric border nozzle switching around the headland

Terminal for nitrogen sensor  
AMAPAD ISOBUS terminal

**ISOBUS**

Nitrogen sensor

200 Hz weighing system with tilt sensor for heavily sloping terrain

Argus radar system for the automatic adjustment of the lateral distribution

Up to 80 automatically switched part-width sections with AmaSwitch or AmaSelect individual nozzle switching

Fully automatic DistanceControl plus boom guidance system with 4 sensors

DynamicSpread ready: up to 128 automatically switched part-width sections with dynamic part-width control

Remotely-actuated AutoTS border spreading system

Requirement-oriented nitrogen fertilisation (Liquid fertilising) and growth regulation

Requirement-oriented nitrogen fertilisation

Base fertilisation, lime

**On-line: Nitrogen sensors**

### GPS-Switch

Automated headland and part-width section control for spreaders, sprayers and seed drills

### GPS-Track

- Parallel guidance aid: potential upgrade to automatic steering

### GPS-Maps

- Application map module for Shape files

### Task Controller

- Application maps and complete documentation via ISO-XML

ISOBUS terminal  
AMAPAD



AmaPilot+ multi-function joystick





# Saving cost and protecting the environment through precision farming!

The IT-Farming concept means that our terminals are universally able to look after the operation, monitoring and documentation of spreaders, sprayers and fertiliser spreaders.

Data is exchanged with other IT farming technologies via defined and accessible interfaces.

## Analysis, interpretation, planning, documentation

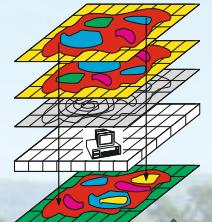

or other  
ISOBUS terminals



Interface  
Tractor > mounted machine



High resolution camera system for added safety when manoeuvring

Autopoint:  
Fully-automatic control of the headland actuation time

Variable sowing rate

Required seedbed  
cultivation intensity

Off-line: PC planning



- Unique Mini View concept
- User profile for different drivers
- Remote access by service technicians
- Up to 128 part-width sections possible
- Quick start – e.g. automated field change



## Data recording:

- Basic data
- Geographical data
- Variable data
- Soil sampling



# AMATRON 3

## One for all

AMAZONE has developed AMATRON 3; a machine overlapping terminal for fertiliser spreaders, crop protection sprayers and seed drills facilitating optimum application rate control and monitoring. A detailed view of both the GPS-functionality and the actual machine operation can be monitored in any operational situation. Fully downwards compatible to AMATRON<sup>+</sup> and upwards compatible to ISOBUS, the terminal bridges the gap between the ISOBUS and non-ISOBUS worlds.



### Plant protection

On AMAZONE UF mounted field sprayers and UG and UX trailed field sprayers AMATRON 3 allows, in addition to the operation of the control chest and boom functions, the fully automatic control of the pre-determined application rate (l/ha) with a quick and precise manual over-ride of any defined application rate changes.

### Fertilisation technology

AMATRON 3 enables the electro-hydraulic activation of the Limiter border spreading device and the hydraulic shutter slides for the forward speed related rate regulation, on, for example, the AMAZONE ZA-M fertiliser spreader in conjunction with the Comfort electronic package.

### Sowing technology

On AMAZONE seed drills AMATRON 3 carries out the electronic tramline control and seed rate changes in pre-determined increments. In addition, the electro-hydraulic functions, such as sowing depth or soil tillage intensity, are controlled via the AMATRON 3.



# AMATRON 3

## Your on-board manager

AMATRON 3 has a VGA screen for maximum colour resolution and also offers a wider viewing angle. The operating keys for the screen are, understandably, backlit for the best ergonomics both under twilight and after dark.



### GPS-Switch

GPS-Switch is the automated headland and part-width section shut-off for spreaders, sprayers and seed drills. The GPS-aided in-cab terminal facilitates the precise switching on and off of the machine in the correct position on the headland, in short work and wedge shaped fields. The working widths and the layout of the part width sections are taken into consideration. Once the machine has initially spread or sprayed the headland the field boundary is recorded and the rest of the field is controlled automatically.

### The advantages:

- High contrast and low reflection display
- One hand actuation
- Optimum matching to the machine
- Serial coupling to various GPS-Terminals
- Coupling up to sensor technology also possible



### GPS-Track

GPS-Track, the parallel guidance aid, proves to be an enormous benefit for when finding one's bearings in the field.

### GPS-Maps

The additional module enables the GPS-based processing of application maps in the Shape file format, both when in AMABUS or ISOBUS mode.

## The AMATRON 3 operator terminal provides the following functions:

- ✔ ISOBUS machine operation
- ✔ AMABUS machine operation
- ✔ Tractor ECU function
- ✔ Task Controller job management for documentation
- ✔ Import/Export of field data via a USB stick
- ✔ GPS-Switch automated part-width section control (optional)
- ✔ GPS-Track parallel guidance system (optional)
- ✔ Optional external light bar display for GPS-Track parallel guidance
- ✔ GPS-Maps application map module (optional)
- ✔ ASD interface via RS232 (nominal rate transfer), for example, with N sensors



# CCI terminal



## The benefits

The CCI ISOBUS terminal from AMAZONE is the result of the cooperation with several other manufacturers of agricultural machinery who are joint participants in the Competence Centre ISOBUS e.V (CCI). With CCI, AMAZONE and its partners have laid the foundation to introduce ISOBUS into practice. The CCI provides a good base in the conversion of all AMAZONE machinery and implements successively to the ISOBUS standard.

- ✔ The bright 8.4" colour display with its high screen resolution and ambient light sensor matches the brightness automatically to the light conditions. This avoids the driver in twilight or at night being blinded by too bright a display.
- ✔ Input either via the operator-friendly touchscreen display or via the soft keys.
- ✔ Fatigue-free operation at night is assisted by the back-lighting of the keys which are also connected with the light sensor.
- ✔ The proven AMAZONE one-handed operation is still possible because the position of the soft keys can be simply mirrored.
- ✔ For intuitive menu guidance and the convenient input of values and text, the terminal is provided with a high-quality touchscreen.
- ✔ For the direct quick, input and adjustment of the input values, a scroll wheel with actuating function is ergonomically integrated in the housing.



## The terminal includes the following functions:

- ✔ ISOBUS machine operation
- ✔ Tractor ECU function (interface for speed, PTO shaft and lower link position)
- ✔ CCI.Control job management for documentation
- ✔ CCI.Command (optional):  
automatic part-width section shut-off CCI.Command.SC  
parallel guidance aid CCI.Command.PT
- ✔ Application maps supported in ISOBUS format
- ✔ USB interface for data exchange
- ✔ Interface for the connection of a GSM modem
- ✔ ASD and LH5000 interfaces via RS232 (nominal rate transfer), e.g. for N sensors
- ✔ Camera function CCI.Cam
- ✔ In conjunction with seed drills, the CCI terminal features the automatic tramline function. Here the tramline position is controlled via GPS with the aid of the parallel driving module of the CCI terminal.



## External light bar for CCI.Command.PT parallel driving aid

As a possible addition, an external light bar is available which can comfortably be coupled with CCI.Command PT. The external light bar can be positioned freely in the tractor cab. The only precondition for its utilisation is the activation of the Parallel Tracking module in CCI.Command.

# AMAPAD

An especially comfortable method of controlling agricultural machinery



## The new dimension in control and monitoring

With the AMAPAD operator terminal, AMAZONE offers an entirely new and high-class solution for GPS applications such as automated GPS based part-width section control and Precision Farming applications.

AMAPAD features an especially ergonomic, 12.1" touchscreen. With the unique "Mini View" concept, applications that do not need to be actuated but which, however, need to be monitored, are clearly shown at the side. If needs be, these can be enlarged by "fingertip" widening. The possibility also exists to customise the display, a feature which rounds off the exceptional layout of this operator terminal.

In addition to GPS-Switch pro part-width section control, a high-quality professional manual light bar guidance system is also installed as standard. GPS-Track can also be upgraded to an automated steering system.

## The terminal includes the following functions:

- ✔ ISOBUS implement operation
- ✔ Task Controller job management for documentation
- ✔ Automated GPS-Switch pro part-width section control
- ✔ Integrated light bar for GPS-Track pro parallel guidance system
- ✔ As an option: upgradable to automatic steering
- ✔ GPS-Maps pro application map module
- ✔ RS232 interface via SCU adapter (for data exchange)
- ✔ Twin USB ports for data exchange
- ✔ WLAN module (via USB adapter)
- ✔ GPS output

## The features of AMAPAD:

- ✔ Screen made from toughened glass
- ✔ Housing made from impact-proof plastic
- ✔ Extra-narrow rim for maximum visibility
- ✔ Flush finish, no penetration of dust/moisture





# Soil tillage from AMAZONE





**SPEED**  
tilling





# Cayros mounted reversible plough

Ploughs for successful crop establishment



Cayros M 950 4 furrow



All headstocks on Cayros ploughs feature a turnover system that uses a double-acting cylinder with automatic changeover. This ensures that the turnover of the plough is smooth and jerk-free, plus it also means that the plough can be turned over using a single-acting spool valve with a pressure-free return as well. The hoses are optimally routed to prevent any potential damage.

AMAZONE ploughs are characterised by their robust technology, an excellent quality of work, optimal adaptation to local conditions and thus offer the highest possible cost-effectiveness.

With the Cayros, AMAZONE offers five models of mounted reversible ploughs in different sizes and designs. The programme ranges from two to four body ploughs in a medium class plough right up to the heavyweight four to six body mounted reversible ploughs which are designed for larger tractors.

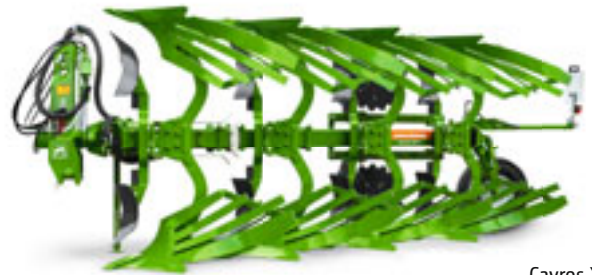

Cayros XM



The plough body is at the heart of any plough and is first in line when it comes to quality of work and is responsible for an effective operation of the plough. Clean, efficient incorporation of those crop residues, even under the most arduous of conditions, such as, for example, in maize stubble, is just one of the quality criteria. But even other challenges, for instance when operating on sloping ground, are also mastered with alacrity. The Cayros plough programme offers a choice of eight different plough bodies and thus guarantees a perfect performance even in the most diverse of soil conditions.



|                               |  |
|-------------------------------|--|
| <b>Working width per body</b> | 32*, 36, 40, 44, 48 cm, mechanically-adjusted<br>32 cm to 55 cm, hydraulic                 |
| <b>Tractor output</b>         | up to 380 hp <span style="float: right;">*only with a body to body spacing of 85 cm</span> |



One specific quality feature of the Cayros ploughs is the heat treatment with the ©plus hardening process for the mouldboards. This heat treatment results in a prolonged longevity, high impact strength and a smaller pulling power requirement and thus reduced fuel consumption.



Cayros XMS 950 VS 5 furrow

By their clever design, many of the components, such as, for example, the turnover mechanism, beams, leg assemblies or other parts can be used to make up many variations in plough specification.

Various beam heights and body clearances, plus three different methods of overload protection paired with a furrow width adjustment in steps or steplessly variable by hydraulics, makes possible a precise and uncompromising matching of the plough specification to any individual application.



Cayros XS



All headstocks come equipped with an elongated hole for the top link. Using this elongated hole position, the tractor/plough combination follows the contours in uneven ground especially well ensuring that the desired working depth is always maintained.

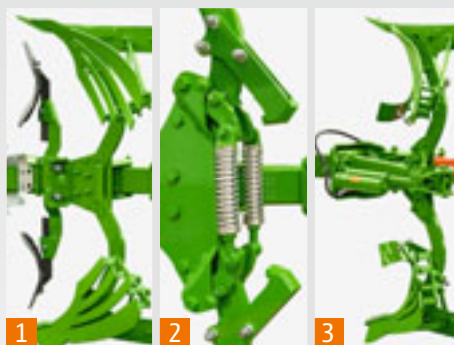

Three different stone safety systems are available from choice. A mechanical system via shear bolts (1), a half automatic release via coil springs (2) or a fully automatic hydraulic version (3).



On the Cayros V, the setting of the furrow width is carried out steplessly and hydraulically from the tractor cab. Needless to say that the system is so sophisticated in design, that the traction point and the furrow width are also correctly adjusted at the same time.



# Cayron mounted reversible plough

Simple setting – ready!



Cayron 200 mounted reversible plough



The headstock is equipped with a one-piece lower link cross shaft which has very good shock absorbing properties and in this way significantly reduces the load on the tractor's rear lift linkage. This is enabled by two pivot bearings, one on each side of the lower link cross shaft, which effectively absorb the shock loads generated.

The Cayron mounted reversible plough is available as a 5 and 6 furrow plough for tractors up to 290 hp. On the Cayron 200 the furrow width of each body is adjustable in three steps of 40, 45 and 50 cm. On the Cayron 200 V the furrow width per body can be steplessly adjusted from 30 to 55 cm, offering the flexibility for different working conditions. On the Cayron, the hydraulic adjustment of the front furrow width comes as standard.

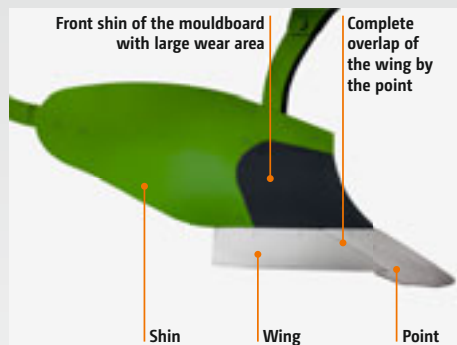

The U 40 C-blade universal mould board features an enlarged mouldboard front shin which entirely covers the wearing area. In addition, it features an especially large coverage from mouldboard to the point.

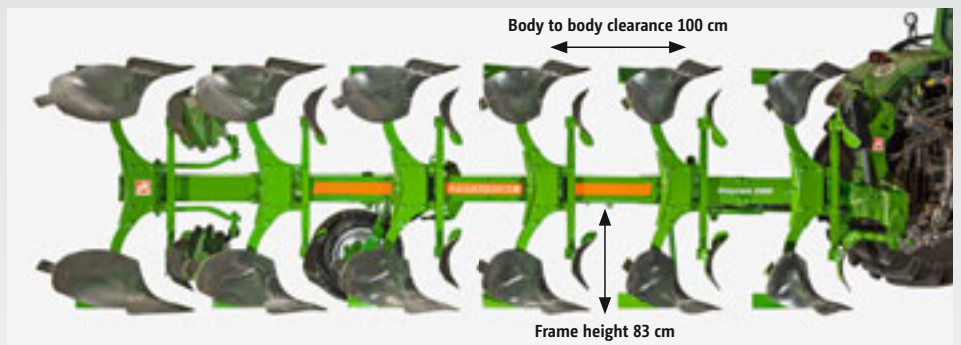

The 100 cm body to body clearance with a frame height of 83 cm and the smooth surface of the large-dimensioned rectangular profile beam provides maximum passage.



|                               |   |
|-------------------------------|---|
| <b>Working width per body</b> | 40, 45, 50 cm, stepped<br>30 cm to 55 cm, hydraulic |
| <b>Tractor output</b>         | up to 290 hp  |



The X-blade widening share is a specific mouldboard extension mounted on the last plough body and creates, on average, a 30% wider furrow bottom.

Cayron 200 V mounted reversible plough

For the plough, AMAZONE employs the exact and comfortable setting possibility. When changing the working width, the front furrow width is matched automatically. This is made possible by the joint communication between the furrow width and front furrow cylinder. The matched hydraulic system of the plough stops the driver from having to readjust the implement.



The especially comfortable conversion from work into the transport position is achieved by folding round the combi wheel.

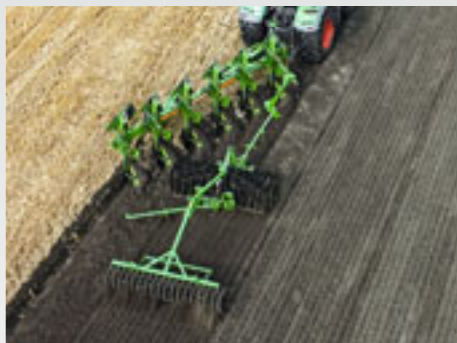

The C-Pack 900 is a single ring packer with a ring diameter of 900 mm. The ring profile of 36° means the universal operation across differing soils.



The optional NRP breaker ring roller is available as a following roller to give a more intensive levelling and crumbling effect.



# Catros Special compact disc harrow

The strong entry-level model



Catros  
460 mm



Catros+  
510 mm

|                      |   |
|----------------------|---|
| <b>Working width</b> | 2.5 m / 3 m / 3.5 m / 4 m, mounted                    |
| <b>Working depth</b> | 3 cm to 12 cm (Ø 460 mm),<br>5 cm to 14 cm (Ø 510 mm) |



Catros+ 3003 Special with serrated discs in 3 m working width

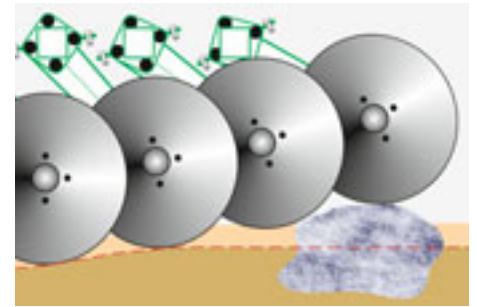

The rubber spring elements allow the optimum adaptation of the concave discs to the field contours.

All Catros mounted compact disc harrows are ideally suited to quick, shallow and intensively mixing soil tillage. Two rows of concave discs break up the surface soil. The high forward speed provides the optimum mixing of soil and straw.

The Catros Special is the ideal entry-level model for small to medium sized farms. Thanks to the foldable side discs, the Catros Special is quickly switched over from transport into the working position so that, during operation, an effective working width is always achieved.



Catros+ Special with wedge ring roller

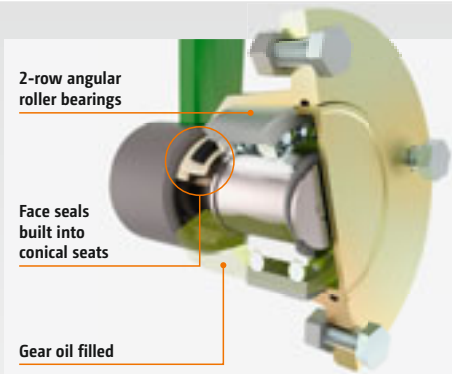

Maintenance-free bearings with slide seal and stone safety release via rubber sprung elements characterise all Catros and Certos slide seals – proven 1,000,000 times over!



The working depth on the Catros Special can be comfortably adjusted by swivelling in and out spacer plates that are arranged centrally to the left hand side of the machine.



The mounted GreenDrill is available for working widths from 3 m to 6 m and is used for sowing fine seeds and catch crops.



# Catros compact disc harrow

Sets the standard; a performance to behold!

|                      |  |
|----------------------|--|
| <b>Working width</b> | 3 m/3.5 m/4 m/<br>5 m/6 m, mounted<br>4 m/5 m/6 m,<br>trailed, bogey chassis |
| <b>Working depth</b> | 3 cm to 12 cm (Ø 460 mm),<br>5 cm to 14 cm (Ø 510 mm)                        |



In combination with the rear harrow, the Catros is also very well suited for seedbed preparation in the spring season.

Catros<sup>+</sup> 5002-2 in 5 m working width with serrated discs (510 mm diameter)

Thanks to their outstandingly easy pulling, all Catros compact disc harrows enable especially high speeds with high acreage outputs. The rigid 3-point Catros mounted machines are available in working widths of 3 m to 4 m, the hydraulically folding 3-point linkage mounted machines come in working widths of 4 m to 6 m.



Catros<sup>+</sup> with serrated discs (510 mm diameter) and cage roller

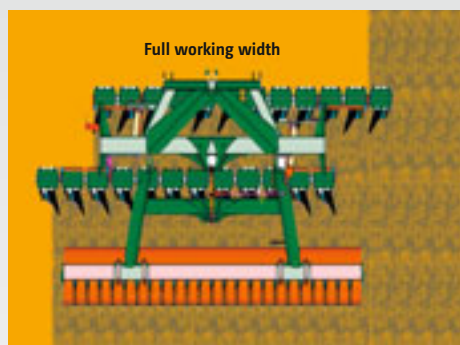

The disc stagger on the Catros is simply adjusted via the square eccentric pin ensuring perfect cultivation always over the entire working width. This means that the stagger of the two disc rows is quickly optimised, and without any tools, via an offset slide.

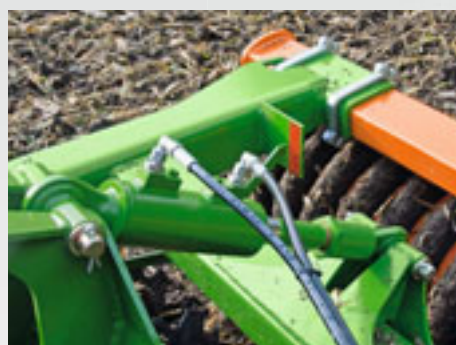

The hydraulic depth adjustment, which can be chosen as an option, offers huge comfort for the Catros and Catros Special. Changeable on the move, it allows the adjustment of the working depth from the tractor cab.



The Catros-2TS in working widths of 4 m to 6 m is equipped with a bogey chassis and drawbar. In the field, its performance is characterised by a very smooth run because the running gear is swivelled completely above the frame.



# Catros compact disc harrow

For maximum acreage outputs

|                      |  |
|----------------------|--|
| <b>Working width</b> | 7 m/8 m/9 m, trailed,<br>integrated running gear |
| <b>Working depth</b> | 5 cm to 14 cm (Ø 510 mm)                         |



For levelling and better crumbling, a Crushboard in front or behind the disc rows is available as option. In this way, especially after ploughing, coarse clods on the surface can be broken up.

Catros<sup>+</sup> 8003-2TX with wedge ring roller with Matrix tyre profile in 8 m working width

AMAZONE offers the Catros<sup>+</sup> compact disc harrow in working widths of 7, 8 and 9 m. The models are characterised by their high efficiency and yet a low specific pulling power requirement and thus are ideally suited for operating behind tractors in the 210 to 350 HP class which are very common on any large estates.



Catros<sup>+</sup> 7003-2TX



Adjustment of the working depth is carried out, very comfortably and as standard, via a hydraulic spool valve from the tractor cab ensuring that the working depth can be flexibly matched to the situation. This allows operation in the field to be as shallow as possible and, on the headlands and in deep wheel tracks, as deep as necessary.

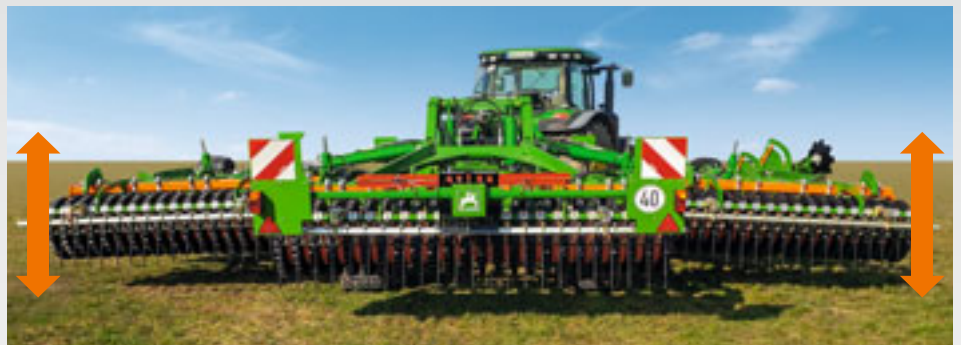

This perfect soil contour following ability is yet further enhanced by the ContourFrame system. Here, the hydraulic rams of the outer sections are pre-pressurised via hydraulic accumulators and then, when moved into the float position, it means that each of the three sections can adapt upwards and downwards to follow the soil contours – even in hilly terrain.



**Working width** 12 m, trailed, bogey chassis  
**Working depth** 5 cm to 14 cm (Ø 510 mm)



The 12 m wide Catros+ 12003-2TS seen here stubble tilling

The Catros+ 12003-2TS supplements the top end of the working width range of the Catros family. With its 12 m working width and the possibility to turn on the roller, the Catros+ 12003-2TS is built for high work rates and offers huge efficiency for larger farms and agricultural contractors.



Safe road transport with a transport width of less than 3 m is assured by the main frame which is hydraulically folding as standard.



Catros+ 12003-2TS with ContourFrame



Thanks to the standard bounce compensation of the drawbar, the Catros travels very smoothly, even under the most arduous of operational conditions.

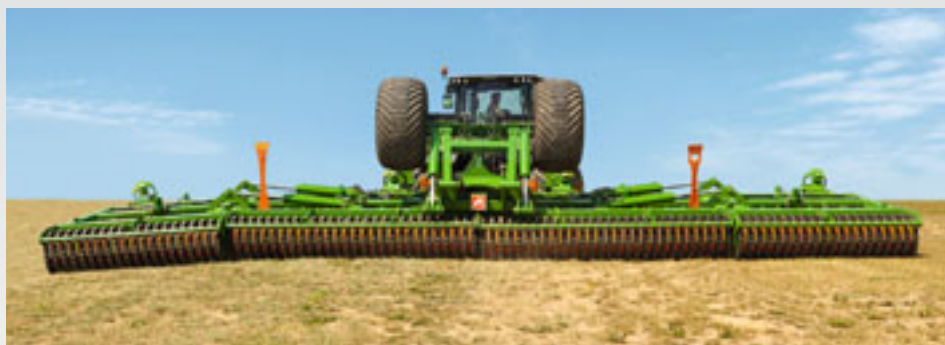

The Catros+ 12003-2TS comes equipped with 510 mm diameter serrated discs making possible working depths from 5 down to 14 cm possible. The ContourFrame on the Catros+ 12003-2TS is divided in four separate segments allowing each of them float. In this way the pressurised hydraulic system allows the individual soil contour following of each of the 4 segments.



# Catros<sup>XL</sup> compact disc harrow

## XL-performance in stubble cultivation



Catros<sup>XL</sup>  
610 mm  
(coarse serrated)



Catros<sup>XL</sup>  
610 mm  
(fine serrated)

|                      |               |
|----------------------|---------------|
| <b>Working width</b> | 3 m/3.5 m/4 m |
| <b>Working depth</b> | 5 cm to 16 cm |



Catros<sup>XL</sup> 3003 in work



Due to the wide disc gang spacing, the Catros<sup>XL</sup> is characterised by its additional free passage of material. Thanks to the open frame construction with plenty of open space, the incorporation of catch crops, grain maize straw or potato haulm is possible without any problem in addition to stubble tillage.

With the new Catros<sup>XL</sup> models, AMAZONE supplements its programme of mounted compact disc harrows in the 3 m to 4 m sector. In contrast to the previous Catros and Catros<sup>+</sup> models, the new Catros<sup>XL</sup> feature bigger discs with a diameter of 610 mm and thus are designed for working depths of up to 16 cm.



Catros<sup>XL</sup> 3003 with wedge ring roller



The working depth adjustment of the disc segment can, from choice, be carried out mechanically or, for more comfort, hydraulically on the move from the tractor cab.



When attached to the tractor, the machine is coupled to the lower links via Cat. 3 pins. However, by simply reversing the pin in the lower link journal, a spacing of either Cat. 3 or Cat. 2 can be achieved.



The new Catros<sup>XL</sup> is equipped with individually adjustable side discs. In the 3 and 4 m versions these discs can be simply folded in for road transport to maintain the relevant transport width.



# Certos heavy compact disc harrow

## The flexible powerpack



Certos  
660 mm

|                      |                 |
|----------------------|-----------------|
| <b>Working width</b> | 4 m/5 m/6 m/7 m |
| <b>Working depth</b> | 7 cm to 20 cm   |



Certos 5001-2TX in 5 m working width

The Certos-2TX heavy compact disc harrow with integrated centre running gear and 660 mm diameter discs can achieve working depths of up to 20 cm. In connection with the machine's high own weight, the Certos-2TX ensures the intensive incorporation of organic matter and a reliable penetration, even on heavy soils. The trailed Certos-2TX series is available in working widths of 4, 5, 6 and 7 m.



To ensure an even depth control of the machine, the Certos-2TX is guided at the rear via the following roller and up front via the support wheels.



Fast road transport  
of up to 40 km/h



The integrated centre running gear results in the high manoeuvrability of Certos-2TX. To maintain a very smooth, comfortable ride and an optimum working performance, the Certos-2TX is fitted as standard with a drawbar shock absorbance system.



The GreenDrill pack top seeder box enables the sowing of fine seeds and cover crops. The 500 l seed hopper is easily accessible.



On Certos-2TX the working depth is adjusted steplessly and hydraulically via the support wheels from the tractor seat. The indicator scale for the depth is easily visible from the tractor seat and allows always the easy depth monitoring.



# Cenius mulch cultivator

Versatile in both conservation and conventional arable farming systems!



Cenius 3003 Special, 3 m with knife ring roller



For operation on light soils with little straw prevailing, the Cenius can be equipped with spring closers.

The 3-stagger mounted Cenius mulch cultivator can be used right from shallow stubble work through to topsoil deep loosening. The increased clearance provides trouble-free material flow even where there is a large amount of straw. The following spring tine levellers or disc pairs evenly level the loosened soil. In conjunction with an active or passive AMAZONE seed drill combination, it offers an excellent entry into conservation cultivation systems.



Cenius Special: Tines with shear bolt protection

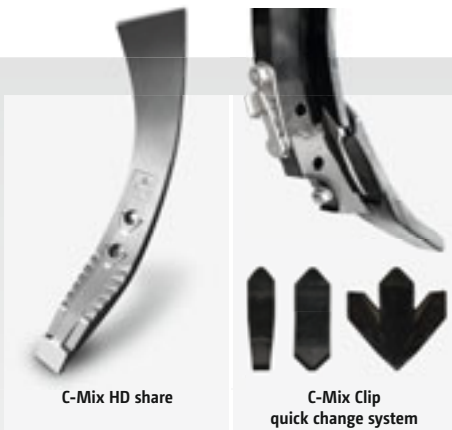

C-Mix HD share

C-Mix Clip quick change system

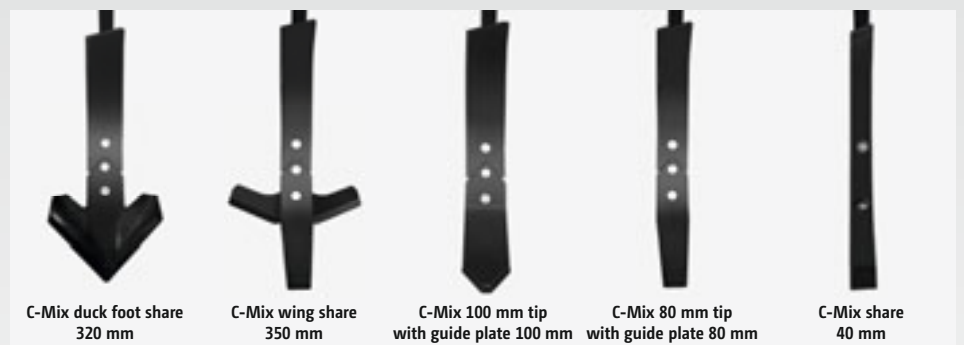

C-Mix duck foot share 320 mm

C-Mix wing share 350 mm

C-Mix 100 mm tip with guide plate 100 mm

C-Mix 80 mm tip with guide plate 80 mm

C-Mix share 40 mm

Optional one-piece C-Mix HD 80 mm hard-wearing variant (HD – Heavy Duty) with hard-metal inserts in the main wear zones.

C-Mix-Clip quick change system. The system allows a comfortable share changeover.

The operational spectrum of the Cenius ranges from shallow stubble work via top soil deep loosening to seedbed preparation. This variation in depth requires a matching range of shares. Separating the guide plate from the share tip above all serves to reduce wearing metal costs. Depending on soil type, site and soil moisture, 3 to 5 share tips can be worn prior to exchanging the guide plate. The guide plates of the C-Mix share system are equipped with a slight spiral to ensure an intensive mixing effect.



3-stagger, 1 row of discs or spring tine closers

Working width 3 m/3.5 m/4 m



Cenius 3003 Super with U-Profile roller

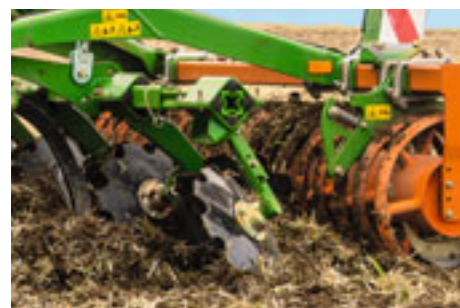

460 mm serrated levelling discs: ideal for working with large amounts of straw due to the increased mixing effect compared with smooth discs and so always a safe drive.

Thanks to the different equipment level options, the Cenius mulch cultivator can be adapted to almost any field condition. The following rollers are available: cage roller, angle profile roller, tooth packer roller, wedge ring roller, wedge ring roller with Matrix tyre profile, U-Profile roller, Double U-Profile roller and the tandem roller.



Cenius Super: C-Mix tines with 600 kg overload protection and 300 mm of lift potential via the release spring – ideal for difficult operating conditions.

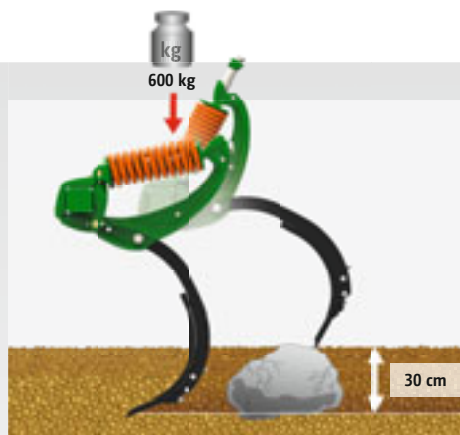

Together with the overload safety protection, the C-Mix tines achieve, even when deep loosening topsoil, the perfect working quality. The release force of the pressure spring overload safety device of the C-Mix Super tine is above 600 kg and features a potential lift height of 30 cm.



The depth setting is carried out mechanically as standard via the turnbuckle or there is the very comfortable, hydraulic adjustment from the tractor seat enabling a response to different soil conditions on the move.



The mounted GreenDrill is available in working widths of 3 m, 3.5 m and 4 m. It is ideally suited for sowing fine seeds and catch crops.

# Cenius-2TX mulch cultivator



Cenius 4003-2TX Super with wedge ring roller

The operational spectrum of the Cenius-2TX ranges from shallow stubble work, via top soil deep loosening, through to seedbed preparation. Of course, this requires a matching range of shares. The 4-stagger layout of the new C-Mix tines with a tine spacing of 28 cm and the frame height of 80 cm, ensures a flexible, blockage-free operation.



Together with the C-Mix Super pressure spring overload stone protection, the tine element in the centre of the machine provides a perfect working performance even when top soil deep loosening. In this way efficient and continuous operation is achieved even under the most arduous of conditions. The C-Mix Special tine with its shear bolt overload safety device is the alternative for light and medium-light soils without stones.



Cenius 5003-2TX Super

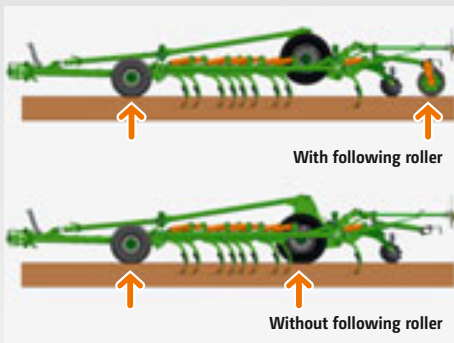

The depth guidance is carried out via the support wheels at the front and at the rear of the machine via the following rollers. Also the running gear can be used as a means of extra carrying capacity and, in very wet conditions; this means that there is the possibility to operate the Cenius-2TX also without a following roller.



The optional hydraulic adjustment of the levelling unit means that the complete set-up of the machine is possible from the tractor cab. Using the clear scale, which is easily visible from the tractor cab, the current working position of the levelling discs is readable.



The optionally available step-less hydraulic depth control enables the adjustment of the working depth whilst on-the-move to react to varying soil conditions and operational conditions.



**4-stagger, 1 row of discs or spring tine closers**

**Working width** 4 m/5 m/6 m/7 m/8 m



Cenius 6003-2TX Super without following roller



The integrated running gear provides the machine with a high manoeuvrability both, on the road and in the field. When equipped with air braking, a fast transport speed of 40 km/h is permissible.

In very wet conditions, in late autumn or when preparing fields prior to winter, the Cenius-2TX can be operated without a following roller. In this special application, the running gear serves also as the depth control. A swivel plate system then fixes the working depth. The tines behind the wheels serve as track eradicators and provide an even quality of work.

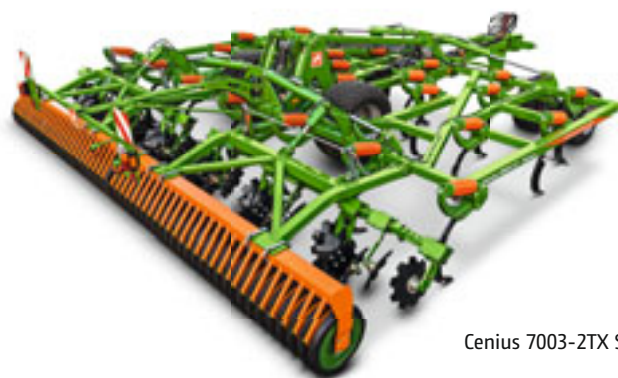

Cenius 7003-2TX Super



As special optional equipment for Cenius-2TX, the GreenDrill seeder box is available. This allows the combined soil tillage and sowing of catch crops in just one operational pass.



As an option, a selectable traction system is available. When activated, it additionally transfers part of the machine weight back on to the rear axle of the tractor with up to 1500 kg being available at a maximum working depth.



The Cenius-2TX is coupled to the tractor via the lower links, a towing eye or a K80 ball coupling. This flexibility allows its use on tractors with caterpillar tracks or centre pivot steering as well its use on standard tractors.



# Ceus disc harrow cultivator combination

Maximum performance in just one pass and offering high flexibility



Ceus 6000-2TX in work

With the Ceus, several operational processes can be combined in one pass. So, the front disc segment with serrated 510 mm discs enables shallow cultivation at working depths of 5 to 14 cm. The following C-Mix-Super tine segment can then be used for the subsequent loosening down to a depth of 30 cm. In this way, the Ceus is suitable for both stubble work as well as for primary soil tillage, deep loosening, and seedbed preparation; especially for farms with plenty of organic matter.



Ceus 6000-2TX Super

Working width 4 m/5 m/6 m/7 m

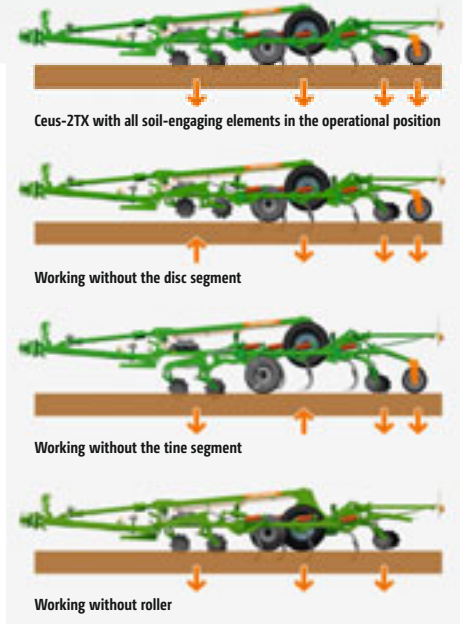

Under very wet conditions, however, the Ceus-2TX can be also operated without a roller system. Then it is no longer guided for depth at the rear by the rollers but via the running gear instead.



The front discs distribute the organic matter by intensively cutting and mixing the crop residues on the soil surface. At the same time, a finely crumbled structure occurs within that top soil layer.

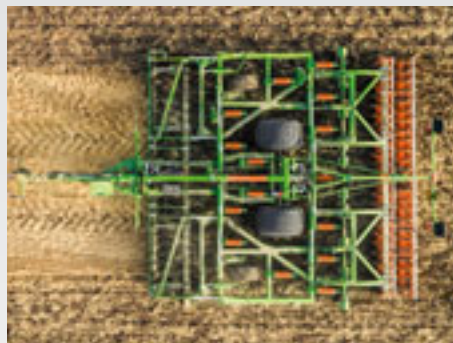

With the following tine segment, loosening of the deeper soil layers down to 30 cm is possible. However, shallow operation is also possible so that, under wet and arduous conditions, the tine tip runs just below the working depth of the disc harrow.

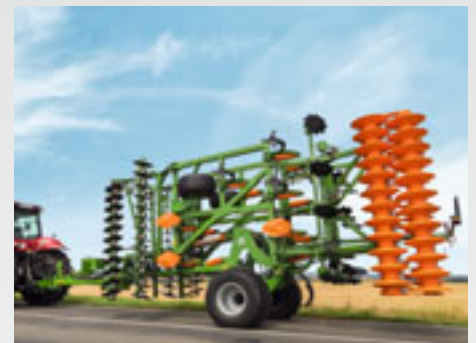

The centrally-mounted TX running gear on the Ceus-2TX ensures good manoeuvrability on the headland and comfortable road transport.



# Following rollers

## Re-consolidation and depth control

SW cage roller



TW tandem roller



PW tooth packer roller

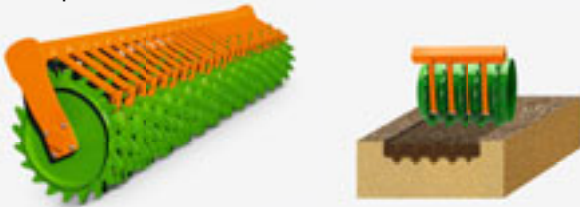

WW angle profile roller



UW U-Profile roller



DUW Double U-Profile roller with rear harrow (optional)



KW wedge ring roller

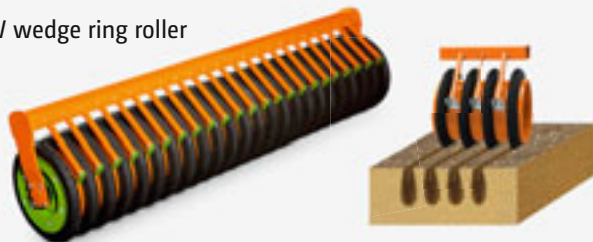

KWM wedge ring roller with Matrix tyre profile

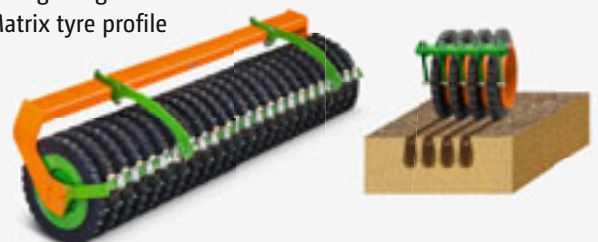

DW disc roller



DDW double disc roller



For reconsolidation of the soil different following rollers are available for AMAZONE soil tillage implements: SW cage roller, TW tandem roller, PW tooth packer roller, WW angle profile roller, UW U-Profile roller, DUW Double U-Profile roller with rear harrow, KW wedge ring roller, KWM wedge ring roller with Matrix tyre profile, DW disc roller or DDW double disc roller.

# XTender and XTender-T rear tank

Large volume hopper for fertiliser application and catch crop sowing in conjunction with Catros and Cenius soil tillage implements

Hopper capacity 4200 l



Fertiliser supply tines with C-Mix 40 shares for Cenius-2TX:  
The depth at which the fertiliser is going to be placed can be adjusted via a flap in the fertiliser supply tines.

XTender 4200 with Cenius 6003-2TX and twin conveying systems for the application of fertiliser and seed

During soil tillage, the XTender rear tank offers the possibility to simultaneously apply fertiliser and/or seed and in this way offers the ideal flexibility when it comes to passive soil tillage. With the XTender rear tank system, sowing catch crops, applying starter fertiliser in catch crops or for adding fertiliser when compensating for straw breakdown are combined into just the one pass.



XTender 4200 with parking and rolling device



The hopper is equipped as standard with a ladder and an appropriate loading platform which offers exceptional access. Thanks to the large hopper opening, filling is quick and simple to accomplish.



The rear hopper is linked to the tractor via the 3-point hydraulic linkage with a choice of either Cat. 3 or Cat. 4N. Coupling the following machine onto the XTender is done also via a second standard linkage with the same linkage sizes.



The trailed XTender-T is ideally suited to tractors without a three-point linkage or those with little lifting power. The running gear permits a support load from the attached implement of up to 4000 kg.



# AW land roller

For perfect soil contact!

|                       |  |
|-----------------------|--|
| <b>Working width</b>  | 6.6 m / 7.8 m / 9.4 m /<br>12.2 m / 15.4 m |
| <b>Tractor output</b> | 80 hp to 180 hp                            |



AW 15400 land roller



The AW rollers are available with either Cambridge or Crosskill rings in all working widths. The individual roller segments with their freely moving intermediate rings are mounted separately from each other in order to ensure outstanding self-cleaning and contour adaptation over the full working width.

The land roller is a universally suitable implement for the professional farmer, from stubble work via seedbed preparation to rolling over-wintered cereal crops.



AW 9400



AW 9400 in transport – also 40 km/h is permissible

The land rollers are ideally suited for rolling after sowing on both heavy and light soils. This is important if reconsolidation on the drill is not used when sowing.

# KE rotary harrow

Ruggedness is the trump card!



KE rotary harrow with tooth packer roller

The KE rotary harrow is the ideal machine for operation following the plough and on cultivated soils. The large frame height and the absolutely smooth trough underbelly and the long tines result in large clearance so that even coarse clods are no problem.

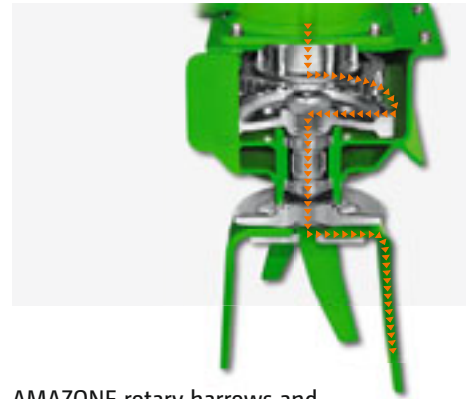

AMAZONE rotary harrows and rotary cultivators with Long-Life-Drive that ensures maximum longevity and smooth running.



KE rotary harrow with tooth packer roller



The value-for-money cage roller gives good reconsolidation with deep-working effect, e.g. for preparatory work for planting machine or for deep drilling.



The tooth packer roller operates blockage free, even on sticky soils and where much straw prevails. Deep scrapers ensure an even surface.



The unique wedge ring roller ensures reconsolidation in strips. The seed is placed in the strips. Suitable for all weather conditions and all soils.



**KE Special**

**Working width** 2.5 m/3 m

**Tractor output** up to 140 hp

**KE Super**

**Working width** 3 m/3.5 m/4 m

**Tractor output** up to 180 hp



Front mounting frame for KE rotary harrow



The PTO through drive shaft can be fitted as an optional extra enabling the rotary harrow to be mounted to a front linkage frame and powered from the rear, or used to drive a pack-top mounted implement, such as a pneumatic seed drill.

The KE Special is the ideal solution for tractors up to 140 hp because it is robust and light at the same time. The KE Special with a working width of 3 m weighs just 850 kg.

The KE Super is the right machine for the demanding requirements of a modern arable farm. Due to its sturdy design, it is fine-tuned against hard permanent stresses. For tractors up to 180 hp, the KE Super is the right rotary harrow for a punchy sowing combination.



KE 3000 Super rotary harrow with tooth packer roller



The Cracker-Disc roller can be combined with a rigid, active soil tillage application. Above all it improves the structure on very heavy soils and leaves a fine-crumbed seedbed.



The side plates are mounted on a sprung suspension which allows them to yield upwards when stones are encountered. A long carrying arm and sturdy springs also make the KE Super reliable to use on stony, heavy soils. This applies also to all rotary cultivators.



Optionally, for both rotary harrows and rotary cultivators the soil can be loosened in the tractor wheel marks with the height and side adjustable eradicator tines. The wheel mark eradicators are equipped with a sprung overload safety device to protect against damage.

# KX and KG rotary cultivator

The original is always the best



Extreme stone test track: The tine spring fixing on the rotary harrow and cultivator allows the tines to give way when stones are encountered.

Strong as an ox, the KG rotary cultivator always keeps to the set working depth, whether the soil is ploughed, tilled or not worked, even in heavy soil, as the tines “on-grip” pull themselves into the soil. Tines “on-grip” break up the soil and no smear horizons are created.



Quick change tine system for rotary harrows and rotary cultivators: The tines are simply pushed into the sockets of the tine carrier and secured with a lynchpin. There is no easier and faster way.



Rotary cultivator with wedge ring roller



Because of the de-mixing effect coarser soil particles remain on the surface. The fine soil remains in the sowing level creating superb germination conditions. In this way the seed is placed into the fine soil. The coarser parts on the surface protect from capping, drying out or erosion. The “Roller-Drill-System” with wedge ring roller, RoTeC Control coulter and roller harrow provides improved seed emergence and increased yields.



The compact TL deep loosener loosens and inverts the soil. This enables AMAZONE to offer one-pass cultivation without ploughing, even where high levels of straw prevail.



|   |                       |                       |                       |
|---|-----------------------|-----------------------|-----------------------|
| <b>KG Special</b>                                     |                       | <b>KG Super</b>       |                       |
| <b>Working width</b>                                  | 3 m/3.5 m/4 m mounted | <b>Working width</b>  | 3 m/3.5 m/4 m mounted |
| <b>Tractor output</b>                                 | up to 220 hp          | <b>Tractor output</b> | up to 300 hp          |
| <b>KX with optional "on-grip" or "trailing" tines</b> |                       | <b>KG (folding)</b>   |                       |
| <b>Working width</b>                                  | 3 m                   | <b>Working width</b>  | 4 m/5 m/6 m           |
| <b>Tractor output</b>                                 | up to 190 hp          | <b>Tractor output</b> | up to 360 hp          |

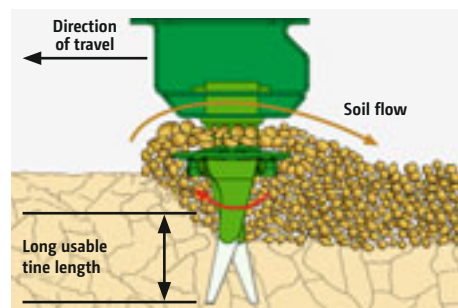

The large through-passage over the rotor carriers prevents any blockages occurring when the tines are heavily worn. The tines can be used for longer thus reducing the wearing metal costs. Also, very uneven ground or large prevailing straw quantities do not lead to the soil bulldozing.

Rotary cultivator KG, 6 m working width

The KG rotary cultivator offers all of the benefits of the rotary harrow yet has a stronger gear trough, thicker rotor shafts and stronger tines. Even in hard going, the rotary cultivator loosens the ground without a problem and simultaneously intensively mixes in the straw. The loose straw-soil mix can, due to the large clearance between the tines and the underside of the gear trough simply pass through unhindered.



Tine carrier made from one piece – 8 mm thick trough profile, 60 mm drive shaft diameter.



The rotary cultivator in 4 m, 5 m and 6 m working widths folds hydraulically down to a 3 m transport width and is suitable for tractors up to 265 kW (360 hp). The main gearbox on the folding rotary cultivator is equipped with a 2-speed lever change for rapid adjustment of the tine speed to different soils and working intensities. The well-laid out, compact design of these extremely robust folding rotary cultivators makes them perfectly capable of high outputs, even in smaller fields.



The working depth of the rotary cultivator is easy to adjust by placing or turning the well-known, four-sided AMAZONE eccentric pin.



# Sowing and precision seeding technology from AMAZONE









# D9 mounted gravity seed drill

Maximum precision sowing!

|                             |                                      |
|-----------------------------|--------------------------------------|
| <b>Working width</b>        | 2.5 m/3 m/3.5 m/<br>4 m/6 m/9 m/12 m |
| <b>Seed hopper capacity</b> | 360 l to 4140 l                      |



D9 3000 Super with Exact following harrow in combination with rotary harrow and tooth packer roller

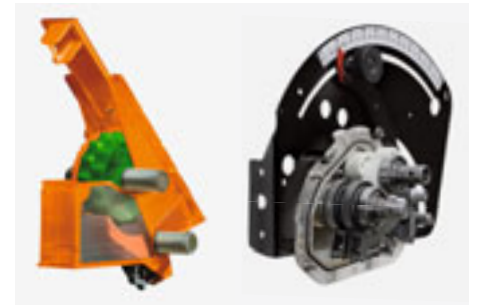

"Control" seed wheels

Vario-gearbox

## DLG FOCUS TEST

(DLG test report 5724F)

| Test criterion                             | Test result | Assessment |
|--|-------------|------------|
| <b>Consistency of seed rate</b>            | very good   | ++         |
| <b>Consistency of lateral distribution</b> | very good   | ++         |

Assessment range: ++/+/0/-- (o = standard)

The D9 three point linkage mounted seed drill can be operated in solo operation or in combination with all active soil tillage machines. The D9 features a strong frame design and large seed hopper. With the new VarioControl metering system seed rates from 1.5 to 400 kg/ha can be sown very precisely and consistently.



D9 3000 Super, 3 m working width



For transport or at the headlands the seed drill is pulled forward with the aid of the "Liftpack" system to reduce the lifting power requirement.



D9, 6 m

The 2.5 m or 3 m D9 Special is ideal for smaller and medium-sized farms. For medium-sized and large farms there is the D9 Super, in 3 to 6 m working widths.



The D9 12000-KR is a 12 m trailed seed drill. Three 4 m wide seed drills with running gear are arranged in the KR trailed carrier system.



# AD pack top gravity seed drill

## Sowing with the optimum seed placement accuracy!

|                             |                         |
|-----------------------------|-------------------------|
| <b>Working width</b>        | 2.5 m/3 m/3.5 m/<br>4 m |
| <b>Seed hopper capacity</b> | 360 l to 1380 l         |



AD 3000 Super, 3 m working width with roller harrow

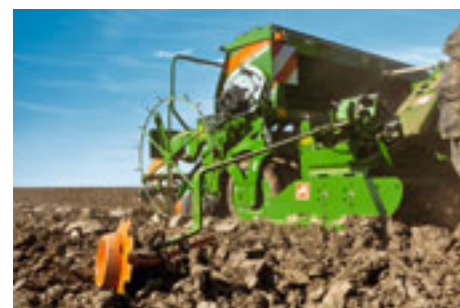

The universal all-round combination for behind-the-plough and mulch sowing: KG rotary cultivator, KW wedge ring roller, AD with RoTeC Control coulters.

The AD Pack Top seed drill can be combined with AMAZONE rotary harrows and rotary cultivators or with a soil tillage machine of other manufacturers. The AD Special is available in working widths of 2.5 and 3 m and the AD Super with an increased seed hopper capacity and in working widths of 3 m, 3.5 m and 4 m.



AD 3000 Super with TL deep loosener



The RoTeC Control coulters, for sowing after the plough or mulch sowing, feature the Control 25 depth guidance roller enabling a tool-less and precise setting of the sowing depth.



The WS Suffolk coulters are arranged in three rows for an optimum passage. They are superbly suited for sowing after the plough or where little straw prevails.



Both the Roller or Exact harrows operate blockage free even with large amounts of surface straw and ensure an even seed coverage.

# Cataya conventional seed drill combinations

Precision with comfort



Cataya 3000 Special with RoTeC coulters and Exact following harrow

The conventional seed drill combination consists of either a KE rotary harrow or KX/KG rotary cultivator alongside the Cataya 3000 Special or Super pack top seed drill.

In its basic version, the seed hopper of the Cataya 3000 Special features a volume of 650 l. With the aid of a 200 l extension it can be increased to a total capacity of 850 l.

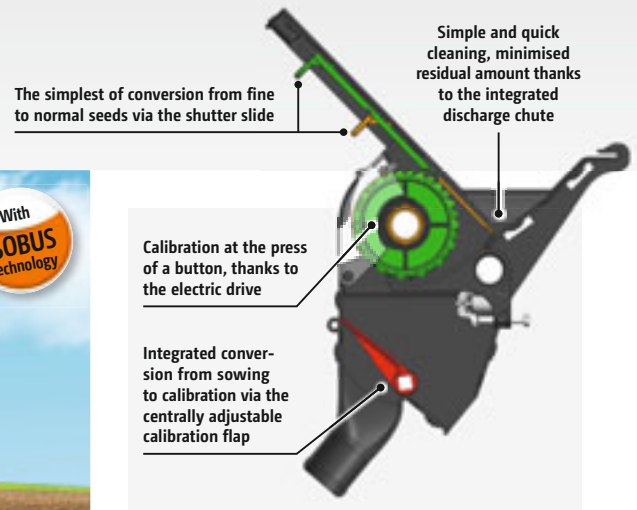

The AMAZONE Precis metering system with integrated discharge chute ensures minimised residual amounts as well as even sowing. With the ElectricDrive, the metering system features electric drive to the seed shaft. Across a wide range of seeds, an outstanding consistency of distribution is ensured.



Cataya Special with RoTeC Control coulters and Exact following harrow



For operation on compaction-sensitive soils and at a reduced working depth, the optionally available tractor wheel mark eradicators make sense. They loosen the packed wheel tracks behind the tractor tyres.



Cataya's new universal setting tool is the ideal solution to avoid all that annoying searching and the need to transport a multitude of tools. Due to its ergonomic shape and the position of all the setting points, any adjustment can be changed instantly.



The Cataya Special is equipped with RoTeC Control coulters with a spacing, from choice, of either 12.5 cm or 15 cm. The basic sowing depth can be set directly at the coulters in 3 different positions.



**Cataya Special**

**Working width** 3 m  
**Seed hopper capacity** 650 l to 850 l

**Cataya Super**

**Working width** 3 m  
**Seed hopper capacity** 830 l to 1270 l



To further simplify the procedure for the operator, AMAZONE offers, with the Smart-Center, a very simple and clear layout of the most important adjustments. Centralised on the left hand side, the metering system can be quickly adjusted and calibrated.

Cataya 3000 Super with TwinTeC coulter and individual coulters harrow

The overall concept of the seed drill and soil tillage implement comes over as being all in one. For the Cataya Super, it is characterised by a slender, yet however, large seed hopper. The 830 l basic volume can be increased with the aid of an extension to capacity of 1270 l, which is, for conventional sowing combinations, a very big capacity and this results in reduced fill times and, overall, in more efficiency.

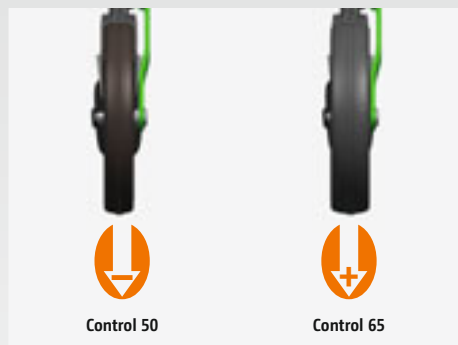
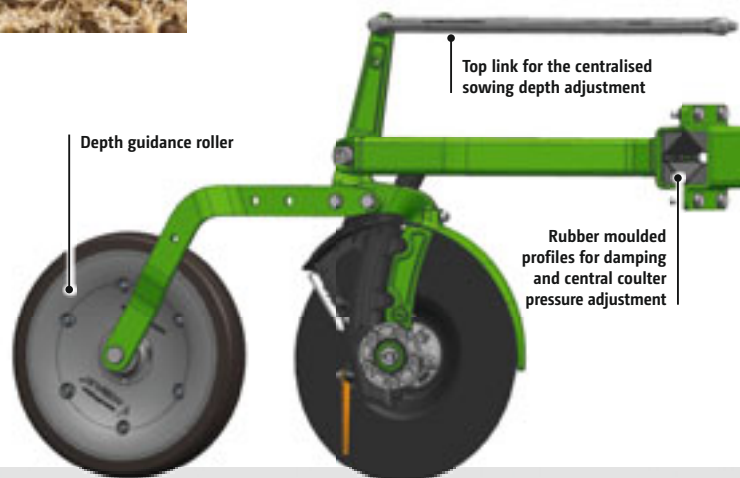

The Cataya 3000 Super power harrow mounted seed drill is equipped with either RoTeC Control single disc coulter or TwinTeC double disc coulter.

The TwinTeC coulters provide a very clean seed placement. The Control 50 mm depth guidance roller has a large passage and is suited especially for heavy soils that have a good carrying ability. The Control 65 mm offers a higher carrying capacity and thus is ideal for lighter ground.



An especially-wide loading board, accessible via folding rear steps, simplifies the filling of the seed drill. The very spacious fill opening dimensions of 2.6 x 0.75 m allows the quick and convenient filling process – not only from big bags and front end loader buckets but also from sacks.

# AD-P Special pneumatic pack top seed drill

Comfortable and multi-talented

|                      |                 |
|----------------------|-----------------|
| Working width        | 3 m/3.5 m/4 m   |
| Seed hopper capacity | 850 l to 1500 l |



The metering unit of the AD-P Special is driven electrically allowing calibration by the press of a button and the very simple adjustment of the seed rate from the tractor cab. The easy accessibility simplifies the exchange of the metering cassettes and calibration.

AD-P 3001 Special RoTeC coulters and roller harrow

The AD-P Special is characterised by outstanding operational comfort and optimised shallow hopper shape design. Seed hopper capacity, from choice of either 850 l or 1250 l, can be increased up to a total volume of 1100 l or 1500 l respectively by the use of an extension. Due to its compact design, the AD-P Special requires only little lifting power. Thanks to the switching on and off of the electric metering unit via GPS-Switch, seed is saved and additional stress relief for the driver on the headland is achieved.



AD-P 3001 Special, 3 m working width with KG 3001 Special rotary cultivator



The roll-over hopper cover is easy to handle and protects the seed hopper from dust and rain.



Thanks to the electric metering system via AMADRILL<sup>+</sup>, the automated calibration function is quick, safe and clean. The seed rate can be adjusted from the tractor seat and, on the headlands, be used to pre-meter the seed in the corners.



The AD-P can be operated via the AMATRON 3, CCI 100 and AMAPAD ISOBUS terminals or with any other ISOBUS compatible terminal, offering the possibility to equip the AD-P with GPS-Switch, the automated headland switch off system.



# AD-P Super pneumatic pack top seed drill

Modern and reliable

|                      |                  |
|----------------------|------------------|
| Working width        | 3 m / 4 m        |
| Seed hopper capacity | 1500 l to 2000 l |



The TwinTerminal 3.0 makes for an even simpler calibration procedure and easy emptying of residual amounts. The calibration procedure can be stopped and started directly down at the machine via the TwinTerminal. This terminal is equipped with a 3.2" display.

AD-P Super with RoTeC pro coulters and Exact following harrow

By combining the seed hopper and the packer roller, the AD-P Super is extremely compact. Due to this compact design, with its favourable centre of gravity, the superbly robust seed drill combination requires a comparatively low lifting power. The components are close coupled to the tractor. The reduced load on the tractor rear wheels also reduces the depth of any wheel marks.



AD-P 3000 Super



Carrying the weight directly on the roller makes it possible for the AD-P Super to have a seed hopper of up to 2000 l. The rotary harrow can move upwards to avoid stones.

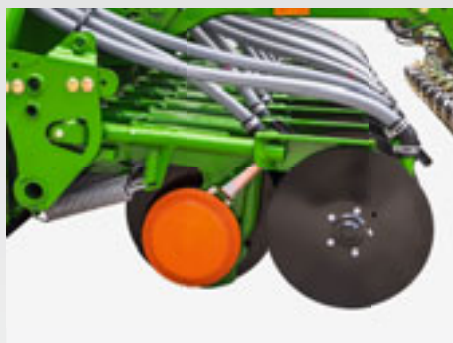

The AD-P Super RoTeC pro roll coulters, with their large diameter and made from hardened boron steel, are ideal when used in the most arduous of operating conditions.



Fill-up times are kept to a minimum thanks to the big seed hopper. The capacity of the basic 1500 litre hopper can be increased by the use of an extension to 2000 l. The open, simple frame concept helps save weight and increases the robustness.

# Centaya Super seed drill combination

## Top-class pneumatic sowing technology



Centaya 3000 Super with TwinTeC double disc coulters

The pneumatic Centaya Super can, from choice, be equipped with a 1600 l or 2000 l seed hopper. The hopper, which is made from plastic, is positioned well forward and thus offers an optimum centre of gravity right up against the tractor.



The hopper opening features a spacious 2.43 x 0.91 m so that the Centaya can be filled via big bags or via a front end loader without a problem. When filling via small sacks, the protective sieves in the seed hopper can be utilised as a loading aid.



Centaya 3000 Super with TwinTeC coulters and Exact following harrow



The seed metering is carried out via the electrically-driven metering unit underneath the seed hopper. When using different seeds, different metering cassettes are available which can then be quickly and easily exchanged.



The segmented distributor head is arranged behind the seed hopper directly above the coulters. Half-side shut off of the Centaya Super via the segmented distributor head is also possible, for instance in asymmetrical tramlines at the field's edge.



Via the SmartCenter, positioned to the left of the machine, the Centaya Super can be comfortably calibrated and adjusted from ground level. The digital weigh scales and a folding bucket are stored in the transport box to the side of the machine.



|                             |                  |
|-----------------------------|------------------|
| <b>Working width</b>        | 3 m              |
| <b>Seed hopper capacity</b> | 1600 l to 2000 l |



Centaya 3000 Super with RoTeC pro single disc coulters

The new Centaya 3000 Super can, from choice, be equipped with TwinTeC double disc coulters or RoTeC pro single disc coulters and at a row spacing of 12.5 or 15 cm. With a coulter pressure of up to 60 kg/coulter, the TwinTeC coulters run very smoothly through the soil and precisely place the seed at the desired depth. The alternative RoTeC pro single disc coulters show their strengths especially where there are large amounts of crop residues and on moist, heavy, sticky soils.

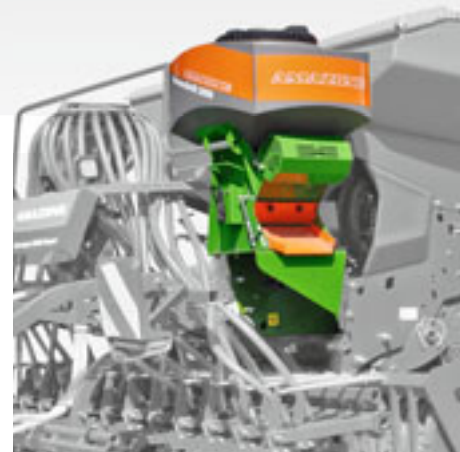

In parallel to the drilling operation, it is also possible that under-sown crops, slug pellets or catch crops can be simultaneously applied with the Centaya. For this, and as an option, the GreenDrill 200E catch crop seeder box, with its 200 l capacity hopper, electrically-driven metering shaft and blower fan is available and can be fitted to the rear of the machine.



KG 3001 Super with Centaya Super



Independent of each other, the seed placement depth and the coulter pressure are also adjusted from the SmartCenter. Thanks to the use of the universal tool these centralised settings are done quickly and easily.



For calibration the driver pushes the calibration tray via a rail from the side to underneath the metering housing and opens the calibration flap. Either via the calibration button or TwinTerminal the calibration procedure can then be started.



For control of the seed drill combination, either the AMATRON 3, CCI 100 ISOBUS terminals or AMAPAD from AMAZONE can be used or, alternatively, any other ISOBUS terminal from a third-party manufacturer.

# Avant mounted sowing combination with front tank

High output operation!

Working width 4 m/5 m/6 m



Avant 6000-2, 6 m working width

The Avant mounted sowing combination with front tank is the ideal machine for contractors and large farms for the efficient sowing following the plough and mulch sowing on large areas. The weight distribution that results from having the seed hopper mounted at the front, with the rotary cultivator and seed rail on the back, provides the optimum axle load distribution.



Avant, 6 m



The front tank can be fitted with a steering front tyre packer rolling the area between the tractor wheels.



The Avant is available as rigid version in 4 m and in a foldable version up to 6 m which folds down to a transport width of 3 m for road transport.



The front mounted seed hopper has been designed to be wide and low so as not to obstruct the driver's view. The same applies to the rear visibility for an uncluttered view of the rear mounted implements.



The blower fan for seed delivery is driven by a hydraulic motor.



# Cirrus Compact trailed sowing combination

Compact, easily manoeuvrable, quick!

|                      |                 |
|----------------------|-----------------|
| Working width        | 3 m/3.5 m       |
| Seed hopper capacity | 3000 l          |
| Row spacing          | 12.5 cm/16.6 cm |



Cirrus 3003 Compact

For smaller sized fields, the Cirrus 3003 Compact makes for a very attractive option. With a hopper capacity of 3000 l, the machine's compact design does nothing but impress with its excellent manoeuvrability. The optimum positioning of the seed hopper for all Cirrus trailed seed drill combinations ensures better tractor traction due to the weight transfer and has more room left for tight turns on the headland as well as free accessibility to the metering system. The fill level of the hopper does not then have any effect on the placement depth of the seed.



With the Matrix tyres, which have been especially developed for the Cirrus, the machine, even when completely filled with seed, can be safely transported on the road at up to 40 km/h where national road traffic regulations allow. Coupling to the lower link arms ensures the superb manoeuvrability of the Cirrus, for instance on the headland.



Cirrus 3003 Compact  
with TwinTeC<sup>+</sup>  
double disc couler



The heart of all Cirrus, and the guarantee of a uniform, quick field emergence, is the Matrix tyres. The combination of the big diameter, together with the new profile, provides an easy rolling effect – and thus a reduced pulling power.



As an alternative for regions with are less sensitive to germination conditions, the Cirrus can also be equipped with a simple AS cross-ply tyre. The self-driving effect from its short cleats is very good and thus the machine is also easy to pull.



The disc harrow with its maintenance-free and uniquely angled discs ensures a superb quality and level seedbed. The working depth can be hydraulically adjusted during operation.

# Cirrus large area sowing combination

Sow successfully – harvest successfully

|                      |                   |
|----------------------|-------------------|
| Cirrus 4003          | rigid             |
| Working width        | 4 m               |
| Seed hopper capacity | 3600 l            |
| Row spacing          | 12.5 cm / 16.6 cm |



Cirrus 4003-2C with RoTeC pro single disc coulters and 4000 litre pressurised tank for seed and fertiliser

The Cirrus 4003-2 in 4 m working width and the 6 m Cirrus 6003-2 provide you with a machine that can offer precise sowing and which returns medium to high yield levels, yet resulting in a relatively high work rates. In addition, the Cirrus-C comes with a pressurised tank to reliably provide Single-Shoot fertiliser metering into the seed row. This model has a twin-tip hopper with a volume of 4000 l. Depending on the requirement; this combined grain and fertiliser model can be filled with seed and fertiliser or just with seed.



Control of all important functions on the Cirrus is carried out via the ISOBUS terminal. This includes all operational functions, as well as the initial setting up of the machine, such as, for example, calibration.



Cirrus 6003-2 sowing combination with TwinTeC<sup>+</sup> double disc coulters



In order to cope with the ever-increasing sowing speeds, the RoTeC pro coulters feature an especially strong coulters bearing point. The Exact S following harrow provides good seed coverage, even under the most arduous of operating conditions and where copious amounts of straw prevail.



The Roller harrow additionally consolidates the soil above the seed furrow resulting in the optimum germination conditions. This is recommended especially for light, dry soils when sowing spring crops or rape.



The TwinTeC<sup>+</sup> double disc coulters system features an infinitely variable hydraulic adjustment of the coulters pressure providing a wide setting range from 15 to 100 kg. In this way, the pressure can be matched quickly and simply to the changing soil conditions.



|                             |                 |                             |                           |
|-----------------------------|-----------------|-----------------------------|---------------------------|
| <b>Cirrus 4003-2</b>        | folding         | <b>Cirrus 4003-2C</b>       | folding                   |
| <b>Working width</b>        | 4 m             | <b>Working width</b>        | 4 m                       |
| <b>Cirrus 6003-2</b>        | folding         | <b>Cirrus 6003-2C</b>       | folding                   |
| <b>Working width</b>        | 6 m             | <b>Working width</b>        | 6 m                       |
| <b>Seed hopper capacity</b> | 3600 l          | <b>Seed hopper capacity</b> | 4000 l (pressurised tank) |
| <b>Row spacing</b>          | 12.5 cm/16.6 cm | <b>Row spacing</b>          | 12.5 cm/16.6 cm           |



The pneumatic GreenDrill catch crop seeder box when mounted on the trailed Cirrus sowing combinations allows the user to apply to the soil surface an additional medium during the sowing procedure. This could be in the form of either seed for under-sowing or for applying slug pellets.

Cirrus 6003-2C with RoTeC pro single disc coulters

With the Matrix tyres, the machine can travel on the road with a full hopper at 40 km/h. This is of special importance to farmers as it offers them road travel that is quick, safe and which conforms legally. The Matrix tyre profile also offers many agronomical benefits in the field.



Cirrus 6003-2/2C with filling auger for seed and fertiliser



The front T-Pack U intermediate axle packer rolls the area in the centre of the cultivation disc segment. In this way, the soil in front of the machine is again additionally reconsolidated which is of benefit on light soils. The pre-running T-Pack U intermediate axle packer can also be operated as a front packer in solo operation.



With the T-Pack S side packer, when using the Cirrus 4003-2/2C and 6003-2/2C under light to medium conditions or following the plough, the soil can be pre-rolled ahead of the disc segment, providing additional reconsolidation.



The pre-running packer concept on the Cirrus 4003-2/2C and 6003-2/2C can be supplemented by the T-Pack IN. This is mounted in the centre of the machine underneath the drawbar and in this way presses the area between the tractor wheels.



# Citan large area seed drill

Fast and cost-effective sowing at the optimum time



Citan 12001-C

With the Citan, AMAZONE offers a seed drill in working widths from 6 m up to 15 m and which are ideal for use in solo drilling systems where seedbed preparation and sowing a split into separate operations. This ensures maximum productivity and the ability to drill at the optimum sowing dates. With operational speeds of up to 16 km/h, the Citan large area seed drill impresses with its high acreage outputs and perfect seed placement.



Precise, full electric metering for the Citan 8000 to 9000: Easy adjustment from the operator terminal and comfortable calibration (alternatively: land wheel drive for Citan 8000 to 15001-C).



Citan 9000



Seed placement is via the RoTeC<sup>+</sup> Control coulters with a 400 mm disc diameter and a pressure of up to 55 kg directly acting on the coulter. Perfect levelling and seed coverage via the Exact or roller harrow.



The AMALOG<sup>+</sup> carries out the setting up and monitoring of the tramline rhythm, hectares sown, fill level and the track marker position. For the Citan 8000 and 9000, the enhanced control of a wider range of important functions can be taken over by the AMATRON 3 operator terminal.



A useful system to assist the driver is the optionally available seed pipe monitoring which detects immediately any blockages down at the coulter and in the tube. Sitting directly behind the distributor head, sensors monitor the seed flow in the seed pipes.



|                             |                   |
|-----------------------------|-------------------|
| <b>Working width</b>        | 8 m/9 m/12 m/15 m |
| <b>Seed hopper capacity</b> | 5000 l/8000 l     |



Citan 12001-C with fertiliser



The Citan 12001-C and 15001-C offer the possibility to also place fertiliser together with the seed into the same furrow. Therefore the hopper is divided and can be filled either 2/3 with seed and 1/3 with fertiliser or maybe a second seed type. If the division in the hopper is not required, the hopper can be completely filled with just one seed type. The metering is carried out via Vario gearboxes which can meter seed rates from 1.5 to 400 kg/ha.

The Citan is a solo seed drill for areas which have been already been worked and which are ready for sowing. In 6 metres right up to 15 metres of working width, a large capacity seed hopper and, with a fuel requirement of under 3 l/ha, these seed drills are probably amongst the most efficient and high-performing sowing systems in the world.



Citan 12001-C



The front mounted seed hopper is easily accessible for filling. Part of the hopper weight is borne directly by the rear tractor axle. The Citan can be folded in to 3 m transport width in a short time.



For operation on loose or poorly reconsolidated soils, wheel mark eradicators are available as option. The wheel marks are loosened and levelled. By hydraulic actuation, the lowering and lifting is carried out automatically on the headland or when folding for transport.



Independent of soil conditions and weather, the RoTeC+ Control coulters enables sowing at higher speeds. The sowing depth is set quickly and comfortably via the coulters pressure. The settings on the coulters allows the precise readjustment for deep sowing operation.

# Cayena tine coultter seed drill

High work rates with precise metering!

|                                     |                           |
|-------------------------------------|---------------------------|
| Working width                       | 6 m                       |
| Seed hopper capacity                | 3600 l                    |
| Fertiliser and seed hopper capacity | 4000 l (pressurised tank) |



Cayena 6001

The Cayena tine seed drill is designed for rapid sowing with or without prior soil tillage. It shows its strengths especially on hard and stony soils and in dry regions where normal disc coultters would fail. Whether used for coarse, medium or fine seeds, for mulch sowing, on ploughed soil or in stubbles, the Cayena, with its 6 metre working width, does an impressive job.



With the full electric metering drive, a precise regulation of the seed rate is made possible.

The Cayena 6001-C, which is equipped also for fertiliser, comes as standard with a 4000 l capacity pressurised tank that is divided proportionally 60:40 into two sections, each with its own full electric metering drive. The seed and the fertiliser are transported simultaneously into the seed furrow.



Cayena 6001:  
36 tine coultters, 16.6 cm row spacing – forward speeds of up to 15 km/h



The TineTeC coultter forms a clean seed furrow free from organic matter. Due to the extremely narrow design little soil is moved. Advantages: Water is saved and the pulling power required for the machine is minimised.



Thanks to the lower link attachment, integrated running gear and hydraulically folding wings, the Cayena is an impressively compact and manoeuvrable unit.



At 3600 l, the seed hopper on the Cayena is large, but still compact. This allows a clear view of the TineTeC coultters during use. The large hopper opening ensures the easy and rapid filling.



# Condor tine coulter seed drill

For direct sowing

|                             |                                    |
|-----------------------------|------------------------------------|
| <b>Working width</b>        | 12 m/15 m                          |
| <b>Seed hopper capacity</b> | 8000 l (2/3 seed + 1/3 fertiliser) |



Condor 15001



The pressurised tank, with a capacity of 8000 l, is divided into 2 sections (2/3 seed + 1/3 fertiliser). The fertiliser applied is transported with the seed into the seed furrow and in this way; for instance, when sowing winter corn, it is possible to apply an appropriate starter dose or when cultivating spring crops in drier conditions then the full optimum fertiliser quantity can be sown directly into the ground without losses.

As a specialist machine for operating directly into stubble, the Condor works with individually depth guided chisel coulters. The machine concept of the Condor has been developed to meet the demand for the further reduction in the sowing intensity in larger working widths of more than 9 m, with a wide row spacing and minimal invasive seed placement.



Condor 15001: wide in the field, narrow on the road with 3 m transport width



The ConTeC pro coulter excels itself, because of the trailing guide wheel, with its precise contour following. The coulter spacing, the 3 stagger layout of the coulters and the high frame height guarantees a blockage-free operation.



For a long service life the coulter tips are equipped with a hard metal coating. The comfortable depth setting means that adjusting the placement depth can be done in the shortest of times.



All the components required for calibration are very accessible being all arranged on the left hand side of the machine. A deflector plate, which fits under the metering unit, makes possible sowing with just one side of the machine.

# Primera DMC large area seed drill

Precision and speed when direct sowing, mulch sowing or conventional sowing



Primera DMC 9000, 9 m working width

The Primera DMC large area seed drill has been designed for direct and mulch sowing in dry regions. With its unique chisel opener, it performs with outstanding quality regarding placement accuracy and seed embedment on ploughed land, on cultivated areas and when direct sowing. The seed is placed beneath crop residues, thus ensuring optimum seed/soil contact and guaranteeing excellent crop emergence.



The parallelogram guided chisel openers allow for optimum adaptation to the soil contours. Against obstacles, the stone safety release gives way vertically and horizontally.

The hoop rings on the Reflex discs provide, for when both direct and mulch sowing a very good depth control and covering of the seed.



Primera DMC 6000-2C



The hard-faced, "on-grip" chisel openers create a clean seed furrow into which the seed and fertiliser is placed.



The 4-stagger arrangement of the opener units on the frame results in a large spacing between the openers to ensure excellent straw passage.



All the chisel openers are mounted on a parallelogram linkage. This prevents any reduction in the accuracy of the desired sowing depth even at different or changing forward speeds and in undulating ground conditions



|                             |                        |
|-----------------------------|------------------------|
| <b>Working width</b>        | 3 m/4.5 m/6 m/9 m/12 m |
| <b>Seed hopper capacity</b> | 4200 l/6000 l/13000 l  |



Primera DMC 12001-2C, 12 m working width



Advantages of the distributor heads: outside of the seed hopper in view of the tractor driver. Seed hopper is clutter-free and easily accessible. Monitoring of the seed-fertiliser flow in the transparent distribution head cover. Optional with seed pipe monitoring.

The 13,000 l pressurised tank on the Primera DMC 9001-2C and 12001-2C helps create a significant reduction of fill times and thus improved acreage outputs when sowing. By dividing the pressurised tank into four chambers of equal size, either seed only, or seed and fertiliser at a ratio of 3:1 or 1:1 can be applied, depending on need. Thanks to the quartering, even two different types of fertiliser can be deposited via the Single-Shoot system together with the seed in the seed furrow.



Primera DMC 12001-2C, 12 m working width

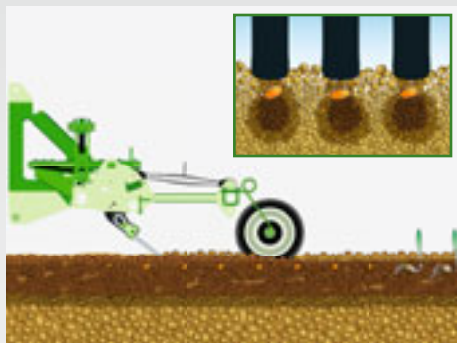

The press rollers on the Roller exact harrow give additional consolidation to the ground directly above the seed furrows. This is recommended especially when drilling spring crops, or rape, in dry, light soil conditions. The Roller bar can be lifted up centrally to quickly take it out of operation if necessary.



Three different metering rollers (large, medium, fine) ensure, as standard, the exact application rates of different kinds of seed and fertiliser. Optionally available: metering cassettes for green manure, maize, sunflowers and for peas and beans.



In order to be able to fill the Primera DMC with both seed and fertiliser, AMAZONE offers a hydraulically-driven filling auger. Using this system the filling time is kept down to just 15 minutes meaning that the output of the drill is even further extended.

# KR trailed carrier system

Flexible operational use!

|                      |          |
|----------------------|----------|
| <b>Working width</b> | 9 m/12 m |
|----------------------|----------|

The KR trailed carrier system offers many versatile permutations of use and therefore can be operated extremely economically. Depending on the application, the trailed carrier system can be equipped with the ED precision air seeder, the D9 seed drill or the Catros compact disc harrow.

For transport, the trailed carrier system can be folded in.



D9 9000-KR | D9 12000-KR seed drills



ED 9000-KR | ED 12000-KR precision air seeders



Catros 9001-KR | Catros 12001-KR compact disc harrows





# GreenDrill

## Pack Top seeder box for fine seeds and catch crop

**GreenDrill 200**

**Hopper capacity** 200 l (electric fan drive)

**GreenDrill 500**

**Hopper capacity** 500 l (hydraulic fan drive)



Catros<sup>+</sup> compact disc harrow with GreenDrill

The GreenDrill seeder box is ideal for sowing fine seeds and catch crops, for instance with the Catros compact disc harrow, the Cenius mulch cultivator or with the Cataya or Centaya sowing combinations.

The seed hopper, which has a capacity of 200 l or 500 l, is easily accessed via the loading step. The fan is either hydraulically or electrically driven.



The Basic equipment level operator terminal for the GreenDrill allows both the seed shaft and the blower fan to be switched plus the speed of the seed shaft can be adjusted. When specified in the Comfort version, the Control operator terminal offers an additional options menu to assist the calibration test and for indicating the forward speed, the worked area and the hours operated.



Cataya 3000 Super with GreenDrill



As part of the metering system, underneath the seed hopper, is the seed shaft where all seed types and seed rates can be sown using either the normal or fine seed wheels provided. The drive to the seed shaft and fan are carried out with an electric motor and hydraulically respectively.



The GreenDrill 500 can be also combined with trailed soil tillage implements.



The GreenDrill 200-E, with its electrically-driven fan, can be combined with either the rotary harrow or rotary cultivator. Here working widths of 3 m, 3.5 m and 4 m are possible.

# ED precision air seeder

Shrewdly engineered!



ED precision air seeder ED 6000-2C Super

The ED precision air seeder precisely singles seeds on a vacuum principle with the vacuum safely pulling the grains onto the nap holes. The accurate grain singling is carried out mechanically via strippers and operates almost independently from forward speed and grain shape. The drive of the seeder units is fully enclosed and thus requires very little maintenance.

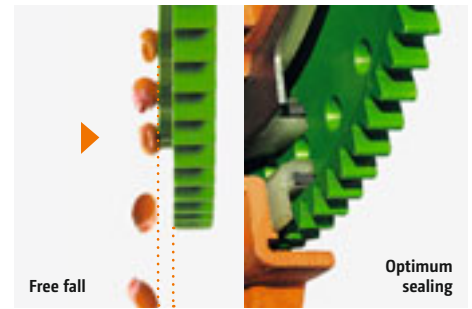

High seed placement accuracy due to the small drop-height and so less “free-fall” of the seeds. Sowing with the clockwork precision!



ED 4500-2C Super



The Classic sowing unit is suitable for sowing maize, sunflowers, beans, rape, peas, cotton, etc. following the plough. The drop height is only 100 mm!



The AMAZONE Contour sowing unit is ideally suited to both mulch sowing and when working after the plough. The outstanding feature is the optimum soil contour following via the depth guidance rollers and the longitudinal tandem.



AMAZONE precision air seeders function according to the vacuum principle. The singling, on both the mechanically (ED Special) or hydraulically (ED Super) driven seeders, is carried out via a stripper finger.



**Working width** 3 m/4.5 m /6 m

**Sowing units** 4 to 12



ED 6000-2C Super precision air seeder

The ED Special features a mechanical fertiliser and singling drive whereas the ED Super, however, is equipped with electric drive for the fertiliser metering as well as hydraulically-driven singling.

Apart from the rigid 3 m and 4.5 m models, AMAZONE also offers folding 4.5 m and 6 m versions. In addition, a front hopper can be utilised as a fertiliser hopper.



In conjunction with the automated GPS-Switch or SectionControl part-width shut-off and the individual row switching, it is possible that the individual units automatically switch on and off via GPS in wedge-shaped fields or on the headland.



ED 6000-2C Super



For filling the ED with fertiliser, AMAZONE offers a hydraulically-driven filling auger, integrated within the machine concept. In this way fill times can be reduced and the work rate of the machine further increased.



The ED can be equipped with one or two micro-granular applicators. In this way, during one pass, up to two micro-granules can be applied to the seed, depending on the machine type.



The Profi electronic equipment via an ISOBUS terminal allows the comprehensive monitoring of the machine as well as comfortable handling.

# EDX high speed precision air seeder

## Xpress grain singling and placement system



EDX precision air seeder, 6 m working width

The Xpress system is characterised by the separated grain singling and grain placement, enabling operational speeds of up to 15 km/h and an increase in the acreage output of up to 50 % in comparison with conventional precision air seeders.



EDX: Higher work rates, more efficiency, less costs!



EDX 6000-TC  
trailed precision air seeder,  
6 m working width



Decisive is the modular separation of grain singling and grain planting. The precise pneumatic singling of the seeds is performed via the centralised singling drums for six or eight rows.



The large openings enable the problem-free filling of the hopper via a front end loader. However, on request, the machines can also be equipped with a filling auger.



With a working width of 9 m yet only 2 seed hoppers have to be filled. This centralisation means shorter filling and set-up times and thus results in an additional increase in efficiency.



**Working width** 6 m/9 m

**Sowing units** 8 to 16/12 to 20



EDX 9000-TC trailed precision air seeder, 9 m working width

With a complete range on offer, AMAZONE has the right model for all relevant farming demands. They all have in common that they can be operated not only in conventional and conservation soil tillage but also by direct sowing. This is valid for sowing maize, sunflowers and rape.



On all EDX machines, the adjustment of the stripper fingers is carried out simultaneously for all the rows. As a special option, electric remote control of the stripper finger is available, enabling the driver to regulate the stripper finger position via the AMATRON 3 in the tractor cab during operation.



EDX 6000-TC with compact folding technology



The two 500 mm diameter carrying rollers per sowing coulters run very smoothly thanks to their wide contact area and support the entire sowing unit. The pressure on the carrying rollers can be adjusted centrally and hydraulically and thus easily matched to the prevailing soil conditions.

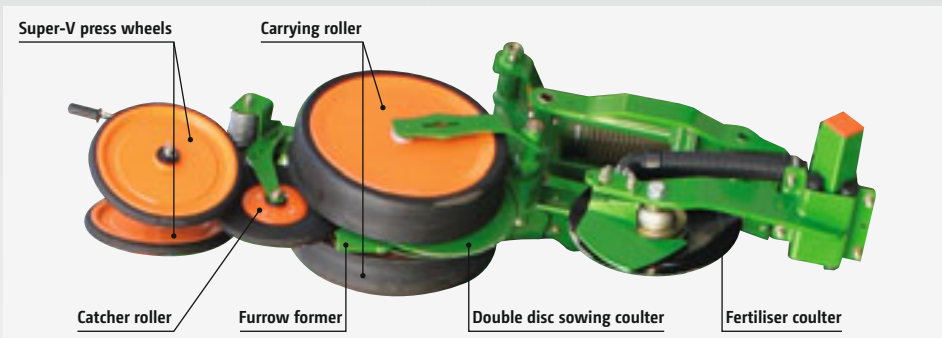

Every Xpress sowing unit is built up of several elements. First a V-shaped angled double disc sowing coulters cuts the soil surface and pushed to one side any crop residues, followed by the furrow former that shapes the furrow and firms it along the bottom. Behind the furrow former the seed is shot into the furrow, caught by the catcher roller and pressed in. Subsequently the multi-adjustable Super-V rollers cover the seed furrow with soil and press it above the covered furrow.



# Fertilisation technology from AMAZONE







# ZA-X Perfect mounted spreader

You'll love it

---

|                        |   |
|------------------------|---|
| <b>Hopper capacity</b> | 500 l / 600 l / 900 l /<br>1250 l / 1400 l / 1750 l |
| <b>Working width</b>   | 10 m to 18 m  |

---



ZA-X Perfect twin disc fertiliser spreader



The maintenance-free oil immersed gearbox is the indestructible heart of all AMAZONE twin disc fertiliser spreaders and has been proven by the 500,000 manufactured to date.

The twin disc centrifugal spreader for smaller and medium-sized farming or grassland farms. The ZA-X Perfect is easy to adjust and enables precise spreading of all usual kinds of fertiliser up to 18 m and urea up to 15 m.



ZA-X Perfect twin disc fertiliser spreader



The OmniaSet spreading discs with their swivelling spreading vanes create a particularly precise, reliable spread pattern.



The optimised steep walls of the twin hopper allow an even flow of fertiliser – even on slopes.



In the vineyard, the spreader's narrow overall width of just one metre prevents damage to the vines.



# ZA-M mounted spreader

We think fertilisation technology through to the end

|                        |  |
|------------------------|--|
| <b>Hopper capacity</b> | 1000 l / 1200 l / 1500 l /<br>1700 l / 2000 l / 2200 l /<br>2500 l / 2700 l / 3000 l |
| <b>Working width</b>   | 10 m to 36 m   |



ZA-M twin disc fertiliser spreader



A high-quality charged-particle paint finish (car industry standard) is used on the hoppers and frame whereas the spreader unit, made completely of stainless steel, guarantees a long life and a high resale value.

The professional twin disc spreader in working widths up to 36 m for farms and contractors. The slowly rotating heavy duty agitators and the low disc rotation speeds ensure a very even, gentle fertiliser flow.



ZA-M twin disc fertiliser spreader



With the aid of the EasySet operator terminal, the left and right hand side outlet apertures can be set individually via a quick press of the soft key and so can be adjusted on the move.

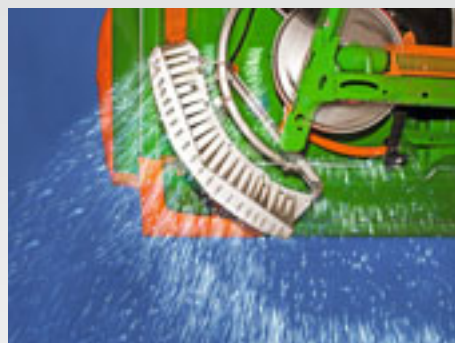

When side, boundary or water-course spreading using the hydraulically-actuated Limiter border spreading device, it is not necessary to either stop the spreading operation or to leave the tractor.



The weighing system at the ZA-M 1001 Special Profis provides controlled comfort and better peace of mind. It determines on-line, with the aid of a weigh cell, the differing characters of the spreading material and automatically compares the actually applied rate with the predetermined rate.

# ZA-V mounted spreader

The spreader for all farm enterprises



ZA-V 2000

With the ZA-V, AMAZONE introduces a highly-efficient fertiliser spreader which has been designed specifically for high operational speeds of up to 30 km/h. ISOBUS communication, weigh cell technology and many other innovations make the ZA-V one of the most state-of-the-art fertiliser spreaders in its class.

The high outputs of up to 390 kg/min and a maximum working width of 36 m allow areas of up to 33 ha/h to be spread.



The base hopper of the ZA-V and ZA-TS is deep pressed and is without corners, edges and weld seams. This provides a continual and even distribution of the fertiliser.



ZA-V 1400



AMAZONE offers the ZA-V with both hydraulic and electrical shutter slide actuation. The hydraulic version allows the direct actuation of the shutter slides via two double-acting hydraulic spool valves on the tractor.



For the ZA-V with hydraulic shutter slide actuation the hydraulically actuated Limiter V border spreading system is available for side, border and water course spreading. Prior to spreading, the recommended working height of the Limiter V is fixed via a pin, depending on the border situation.

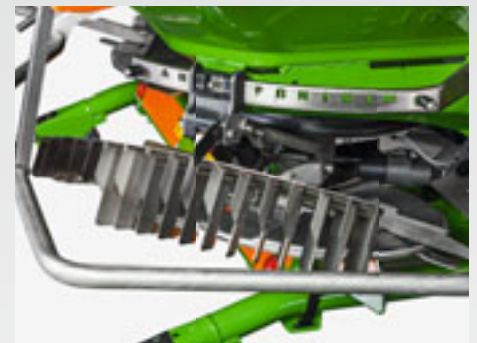

For spreading adjacent to fields, roads or water courses, the ZA-V can also be equipped with the electrically actuated Limiter V<sup>+</sup> which is available as an option. Then the border spreading device can be smoothly lowered into the fertiliser flow to the desired height.



**Hopper capacity** 1400 l / 1700 l / 2000 l / 2200 l / 2600 l / 2700 l / 3200 l / 4200 l  
**Working width** 10 m to 36 m



ZA-V 2700 Profis Tronic with foldable ladder



The strong frame and favourable centre of gravity position characterise the ZA-V as a robust mounted implement. The Super frame provides a payload of 3200 kg whereas the Ultra frame takes up to 4500 kg.

With the different hopper extensions, the ZA-V can be matched to any farm structure with the suitable hopper size of 1400 l to 4200 l.

No hydraulic connections are necessary when mounting the ZA-V Easy. So, in order to operate the spreader, just one 3-pin power cable and the PTO shaft have to be coupled up to the tractor.



With the aid of the EasySet operator terminal, the spread rate shutter apertures can be electrically set via key pressure independently of each other to either side and can be readjusted on the move. This also allows the rate to be individually adapted to the left and right hand side.



The AMASPREAD+ in-cab terminal provides forward speed related spread rate regulation. The actuation of the Limiter V+ border spreading device, which can be fine-tuned between normal, side or border and water course spreading, is done via the push of a button directly from the tractor seat.

With the practical and cleanly arranged AMATRON 3, CCI 100 or AMAPAD ISOBUS operator terminal only one terminal is required to control all the different fertilising functions. All the relevant data is clearly displayed.

# ZA-V Profis mounted spreader

He who weighs, wins!



ZA-V 2000 Profis Tronic weigh cell spreader with Limiter V<sup>+</sup>

The mechanically-driven ZA-V Tronic spreader features an 8 fold part-width section control via spread rate adaptation.

The ZA-V Profis Control weigh cell spreader, with the AMASPREAD<sup>+</sup> in-cab terminal, includes forward speed related spread rate regulation as well as a state of the art 200 Hz weighing system via the two weigh cells. As option for the ZA-V Profis Control, a tilt sensor is also available which continually ensures the precise weight even in hilly terrain.



The weighing system offers controlled comfort as well as more peace of mind. With its 200 Hz weighing system, it works on-line to determine the different characteristics of the spreading material – and all this with the highest degree of measuring accuracy. It automatically compares the actual applied rate with the pre-determined rate.



Spreading disc with the QuickSet adjustment system



Due to its large aperture, the ultra-modern spreading system on the ZA-V can achieve application rates of up to 390 kg/min. The hopper tip, which tapers down to the shutter slide, prevents any residues being left making the machine easy to clean.



The mechanical star agitator of the ZA-V is positioned directly above the deep aperture and in this way provides a reliable and consistent fertiliser flow at all application rates. Turning at just 45 rpm, it makes for a fertiliser-protecting operation.



Only 3 pairs of spreading discs cover the entire operational range from 10 m to 36 m. The working width is simply, quickly and safely adjusted via the spreading vane position. Setting of the spreading vanes is carried out without any tools via the QuickSet adjustment system.



# ZA-V Profis Hydro mounted spreader

Equipped as standard with 16 fold part-width section control, Profis weighing system and ISOBUS communication



Schematic representation of the hydraulic drive on the ZA-V

The ZA-V Hydro with hydraulic spreading disc drive allows side, border and water course spreading to either side as well as a 16-fold part-width section control. The switching over between these individual functions when spreading on the headland is possible on the move.

In addition to a fertiliser-saving, simply interchangeable and adjustable spreading at the field's border, the ZA-V Hydro also provides the benefit that this spreader operates completely independently from the tractor engine speed thus saving fuel.

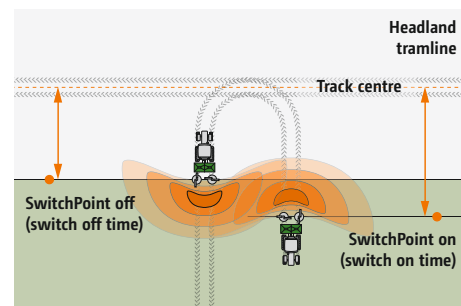

When utilising GPS-Switch, SwitchPoint means the adjustment of the switch on and switch off points depending on fertiliser type and working width. Both values can be taken from the spreading chart and entered into the relevant operator terminal.



The 8 or 16 fold part-width section control of the ZA-V allows actuation of individual outer part-width sections.

The actual quantity of 500 kg is calculated and displayed in AMATRON 3.

**Example:**

- The tilt sensor detects a gradient of 10°
- The weigh cell on the ZA-V Profis registers 483 kg

On the ZA-V Profis, any possible influences due to a change in the centre of gravity are taken into account by the on-the-move measuring procedure with the aid of the tilt sensor. The two-dimensional tilt sensor, which detects angles to the front and back or side to side, corrects any errors in the measuring procedure which might occur when driving up and down hills or when driving across a slope.

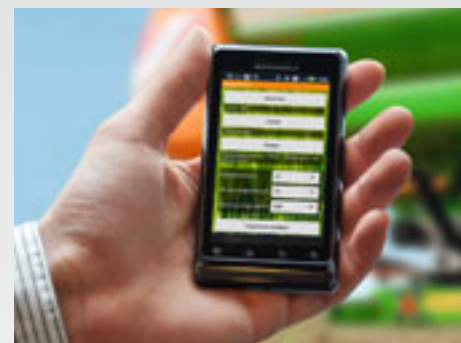

FertiliserService on line: you can access our database, 24 hours a day, free of charge at [www.amazone.de](http://www.amazone.de) giving the up-to-date settings for both lateral distribution and spread rate for AMAZONE fertiliser spreaders. This data is also available via an App for iPhone and other Smartphones.

# ZA-TS mounted spreader

## The new high output spreader with Top Speed

|                        |   |
|------------------------|---|
| <b>Hopper capacity</b> | 1400 l / 1700 l / 2000 l /<br>2200 l / 2600 l / 2700 l /<br>3200 l / 4200 l |
| <b>Working width</b>   | 15 m to 54 m  |



ZA-TS 4200 high-performance fertiliser spreader



The delivery system, with the electrically driven agitator starts in the hopper bottoms, ensure an even fertiliser delivery onto the spreading disc. The slowly rotating, star shaped segments of the agitator evenly deliver the fertiliser to the relevant outlet opening.

The ZA-TS high output spreader, with working widths of 15 up to 54 m, incorporates the integrated AutoTS border spreading system. The very consistent, triangular normal spread pattern, with its large throwing width and large overlap zones, reduces any sensitivity to wind, undulating ground or to changing fertiliser characteristics. The AutoTS border spreading system makes it possible for the operator to reliably generate a very steep cut-off to the border spread pattern and thus create the perfect growing conditions right up against the field edge. The ZA-TS, with its large throwing width when normal spreading and extreme accuracy when border spreading, offers double the perfection.



ZA-TS 2000 high-performance fertiliser spreader



The TS spreading system with integrated, electro-mechanical operation of the AutoTS boundary spreading system – for normal and border spreading a different spreading vane is activated. This outstanding border spread pattern does not require a disc change – but is carried out remotely from the tractor seat during operation.

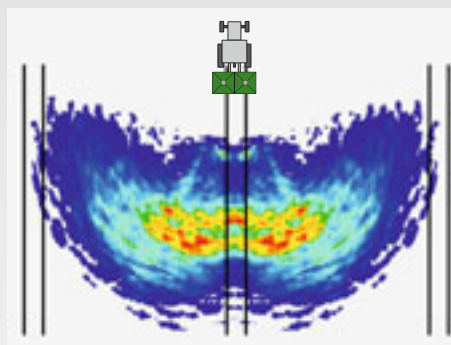

The special shape and angling of the spreading vanes at the ZA-TS result in a multi-layer spreading pattern. In this way the spread fans of the long and short spreading vanes do not interfere with each other and get their optimised trajectory.



The hydraulic-operated roll-over cover with the ZA-V and ZA-TS enables you to continue spreading even when the weather conditions turn against you.



# DynamicSpread and Argus Twin

## Automatic spreader with up to 128 part-width sections

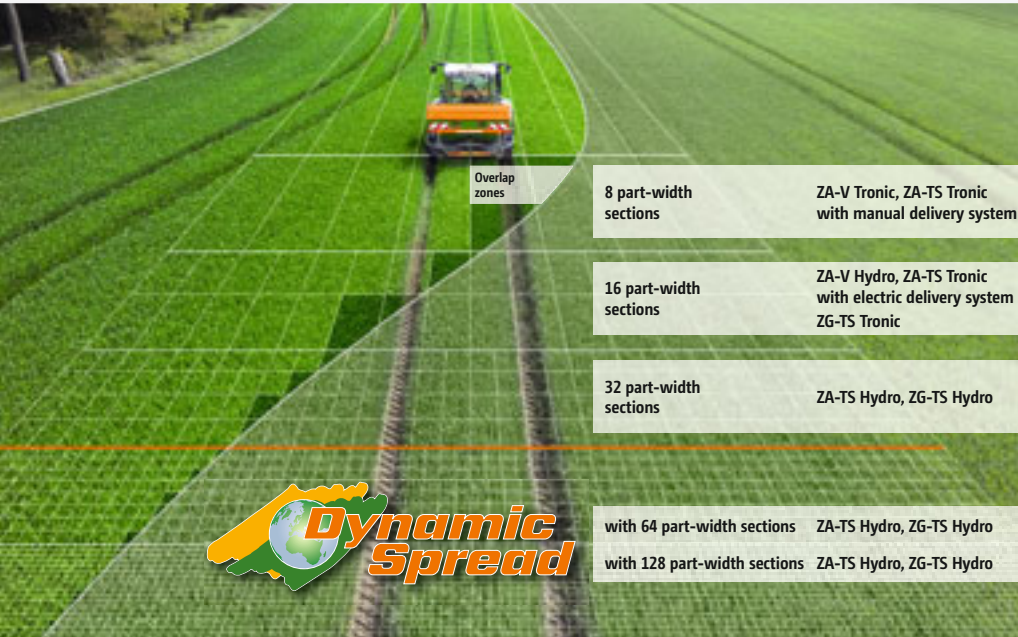

The ZA-TS spreaders can be equipped with the Argus system for spread fan recognition. Argus Twin, via radar sensors, permanently monitors both the left and right hand spread fans and then automatically corrects them, independently of one another, using the electrically-actuated delivery system if necessary.

ZA-TS 3200 Profis Hydro high output spreader

The weighing system of the ZA-TS Profis, with its optionally available integrated tilt sensor, ensures accurate rate control even in hilly terrain. The ZA-TS comes as standard with 8 or 128 fold part-width section control. For the ZA-TS Tronic, part-width section control is carried out via a mixture of delivery system adjustment and spread rate adaptation whereas on the ZA-TS Hydro, section control is done using a combination of disc speed, delivery system adjustment and spread rate adaption. Of course, the part-width sections on ZA-TS spreaders can be also be controlled via GPS. The savings on fertiliser and the benefits of avoiding lodged grain have been clearly proved.



DynamicSpread:  
64 or 128 fold part-width section control on the ZA-TS



The robust rolling and parking device for the ZA-V and ZA-TS eases both the coupling and the uncoupling of the spreader and when manoeuvring it around off the tractor when in the yard. The castor wheels are quickly folded in and out and optimally protected against dirt.



The peripheral guard tube on the ZA-V and ZA-TS fulfils any health and safety requirements. Large-dimensioned marker boards and the road lighting kit ensure better visibility in and amongst road traffic.



The additional mud flaps on the ZA-V and ZA-TS ensure that no dirt is thrown from the tractor wheels onto the spreading discs.

# ZG-TS trailed fertiliser spreader

## Outstanding precision for the highest of demands

**Hopper capacity** 5500 l / 8200 l

**Working width** 15 m to 54 m



ZG-TS 8200 Profis Hydro bulk fertiliser spreader

The ZG-TS is a high-performance trailed spreader for the quick and precise application of mineral fertilisers. It impresses with its outstanding precision and enormous work rates due to the TS spreading system and the comfort offered by the ISOBUS operating terminals such as AMATRON 3, CCI 100 and AMAPAD and is available in two hopper sizes of 5500 l and 8200 l.



The sheet metal is manufactured from high-quality steel to withstand the abrasion caused by the fertiliser. The ZG-TS high-performance trailed spreader comes with a mechanical spreading disc drive, whereas the ZG-TS Hydro has hydraulically-driven discs.



ZG-TS 5500 bulk fertiliser spreader



To ensure that the fertiliser is handled as gently as possible, the AMAZONE Soft Ballistic System pro is integrated as standard into the mounted ZA-TS and trailed ZG-TS spreaders. Agitators, spreading system and discs are optimised to work together.



With the TS spreaders the electrically-driven star agitators in the hopper tips provide the even delivery of the fertiliser flow onto the spreading disc. They are automatically switched off, independently of each other, when either shutter is closed.



Over-sized tyres reduce the ground compaction and make operation possible even under the most difficult of conditions. Tyres with a cleated AS profile can be specified with a track width from 1.8 up to 2.25 m.



# ZG-B bulk fertiliser spreader

Maximum precision!

**Hopper capacity** 5500 l/8200 l

**Working width** 10 m to 36 m



ZG-B Super bulk fertiliser spreader

The ZG-B bulk fertiliser spreader for large-scale farms and contractors has a large hopper volume and robust running gear for speeds up to 50 km/h.

The rubber floor belt can be easily removed from the base frame for maintenance. Included: automatic floor belt alignment for constant conveyor centring.



The large-volume tyres reduce pressure on the soil. The hopper can simply be filled from the silo or the loader.



ZG-B Drive



The ZG-B models have a universal spreader unit for the application of earth-moist materials (lime) up to 15 m and mineral fertilisers up to 36 m spreading width.



The ZG-B Drive features a speed-related spread rate control via the electro-hydraulically regulated rubber floor belt and AMATRON 3.



The ZG-B Drive with AMATRON 3 is equipped with OmniaSet discs for accurate mineral fertilisation.



# Plant protection systems from AMAZONE







# UF mounted sprayer

## Superbly light profile design

|                      |                                |
|----------------------|--------------------------------|
| <b>Tank capacity</b> | 900 l/1200 l/<br>1500 l/1800 l |
| <b>Working width</b> | 12 m to 30 m                   |



The DistanceControl plus boom guidance is equipped with four sensors. In addition to the increased number of sensors the regulating software now allows the optimum boom guidance even at higher forward speed and with reduced target area heights.

UF 1201 mounted sprayer with 18 m Super-S2 boom

Available up to 1800 l, all UF mounted sprayers have a light yet very robust frame and a slim, close-coupled tank position making them easy to carry. The modern polyethylene tanks with their rounded off design ensure perfect agitation and cleaning and minimal spray residual volumes. Due to their special profile design, all AMAZONE booms are superbly robust, yet at the same time extremely light and their conical hinge pins without grease nipples make them virtually maintenance free.



UF 901 mounted sprayer

As standard the hydraulically folded Q-Plus boom from 12 m to 15 m working width allows the left hand folding seen in direction of travel.

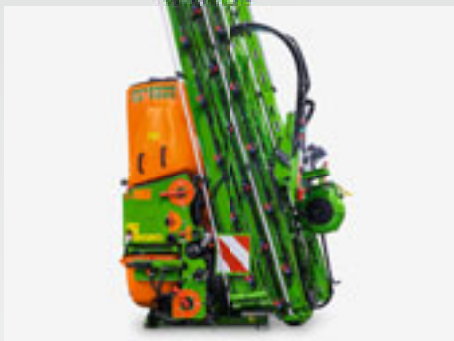

The Super-S1 boom is available in working widths of 15 m, 18 m and 21 m. The working width of the 18 and 21 m versions can be easily reduced to 15 m by just folding in the outer boom segment.



The hydraulically folding Super-S2 boom of 15 m to 30 m has a very narrow transport width of just 2.4 m. Pre-select or Profi-fold allows many folding and angling permutations.



The operator station of the UF is located on the left hand side of the machine. Only three operating taps are sufficient for the actuation of all functions.



# UF 2002 mounted sprayer

Efficient – operator friendly – comfortable

## UF 2002 mounted sprayer

Tank capacity 2000 l

Working width 15 m to 30 m

## Front tank FT 1001

Tank capacity 1000 l



The SmartCenter operator station is equipped with a large hinged door that protects all the relevant operating controls and the induction bowl from dirt and water splashes. In the inner panel of the swing door, a holder for gloves and a measuring jug is provided.

UF 2002 mounted sprayer with 30 m Super-S2 boom

The UF 2002 features a tank with a nominal volume of 2,000 l. The specially shaped, polyethylene tank is integrated into the main frame to give a favourable centre of gravity. The UF 2002 frame has been designed completely around to the new tank design. The reinforced steel profiles provide enormous rigidity, yet at minimal weight.



UF 2002 mounted sprayer with 30 m Super-S2 boom

## Front tank FT 1001

The value for money self-propelled machine



The special advantages of easily-maneuvrable tractors in smaller fields and the better control in sloping conditions are strong arguments for the front tank solution.



The tank shape was designed in such a way that both, on the road and also in row crops the view forward is not obstructed.



The FlowControl fill level management in the ISOBUS terminal provides the optimum, fill-level dependent homogeneity of the spray chemical mix in both tanks.

# UX trailed sprayers

Utmost efficiency!



UX 4200 Super trailed sprayer

The UX, with a maximum nominal volume of 6200 litres and in boom widths of up to 40 metres, has a very low centre of gravity and is of very compact design. The sprayer is manoeuvrable, light to pull and designed for optimum boom coverage, with the best possible spraying and transport speeds.



The compact tank with perfectly smooth inner walls with no nooks, crannies to prevent washing out, has a very low centre of gravity.



UX 6200 Super with tandem pump



All the controls are logically and unmistakably arranged on the left-hand side when viewed in the direction of travel.



The large, swing out induction bowl with ring line and three additional nozzles is very well suited to all product formulations. The rotating canister flushing nozzle operates very effectively.



The axle pivot steering ensures an especially smooth boom ride and great stability in all driving conditions. The AutoTrail steering ensures precise tracking.



**UX 3200 Special, UX 4200 Special** with single pump

**Tank capacity** 3200 l / 4200 l

**Working width** 18 m to 30 m

**UX 3200 Super, UX 4200 Super, UX 5200 Super, UX 6200 Super** with tandem pump

**Tank capacity** 3200 l / 4200 l / 5200 l / 6200 l

**Working width** 18 m to 40 m



UX 5200 Super trailed sprayer

Profi-fold is the electro-hydraulic actuation of the boom. The functions of height adjustment, folding in and out, one-sided independent fold, boom width reduction and tilt adjustment (Profi-fold I) are easily controlled via the ISOBUS terminal. Additional boom tip angling is possible with Profi-fold II.



Everything fits: The boom is securely locked into its transport position. Shock loads are dampened not only in the field but also in transport position via the parallelogram suspension. This means pure comfort and above all ensures a long service life of the boom.



UX 3200 Special with single pump



With a transport width of just 2.6 m, the Super-L2 boom, from 21 m to 40 m, folds down very narrow next to the tank. With a maximum transport height of just 3.8 m, the UX is very compact, even with high tyre sizes (18.4R46).



Alternatively, the Super-S2 boom, from 18 m to 28 m, can also be used on the UX. All booms can be automatically controlled with DistanceControl parallel to the target surface.



The parallelogram suspension of the UX enables spraying heights of 0.5 m to 2.5 m to be achieved. The boom position is excellent in all directions due to optimum co-ordination of the suspension system.

# UX 01 Super trailed sprayers

## Comfortable operation down to the last detail

|                      |                          |
|----------------------|--------------------------|
| <b>Tank capacity</b> | 4200 l / 5200 l / 6200 l |
| <b>Working width</b> | 27 m to 40 m             |



UX 5201 Super trailed sprayer



For the UX 01 also a new steering axle with a maximum steering angle of 28° is available. Thanks to this big steering angle and the compact design of the UX 01, it can circumnavigate very tight curves. Depending on tyre size and track width, a minimum turning radius of 4.5 m is possible.

The UX 01 Super trailed sprayer is available in tank capacities of 4200 l, 5200 l or 6200 l and, as standard, all machines feature a completely covered underbelly which allows plants to pass smoothly underneath the machine thus effectively protecting them from damage. For the UX 01, Super-L2 booms from 27 to 40 m are available.



UX 5201 Super trailed sprayer



Underneath the cover on the left hand side is located the SmartCenter with its induction bowl and complete operator station. Here also are the fill ports for suction and bowser filling as well as two dustproof storage compartments and the TwinTerminal 3.0.



The Comfort-Pack offers in addition a touchscreen for machine operation. The actuation of the spray agent circuit is then carried exclusively out via this touchscreen display which also functions perfectly even when using gloves.



For inducting powders or granular spray agents, an additional mixing nozzle is positioned underneath the suction aperture which safely prevents any blockage of the suction aperture. This mixing nozzle can be steplessly adjusted for intensity.



# ContourControl and SwingStop

## Active boom guidance with active yaw movement stabiliser



UX 01 with ContourControl and SwingStop

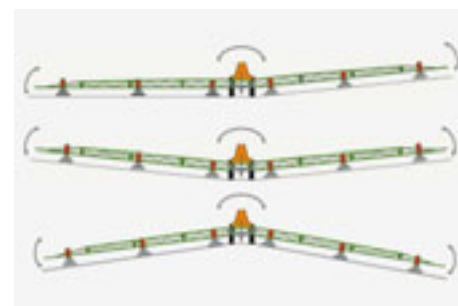

Within the standard specification of ContourControl boom guidance, six ultrasonic sensors are included which are evenly distributed over the complete working width of the boom. The two outer sensors on each side control, independently of each other, the angling of the left and right hand boom. The sensors in the middle scan the crop to the left and right hand side of the machine and regulate the height of the centre segment.

The active ContourControl boom guidance reduces the degree of vertical boom movement.

As special optional equipment for ContourControl, AMAZONE offers the active SwingStop yaw stabilisation system to reduce the amount of horizontal boom movement.

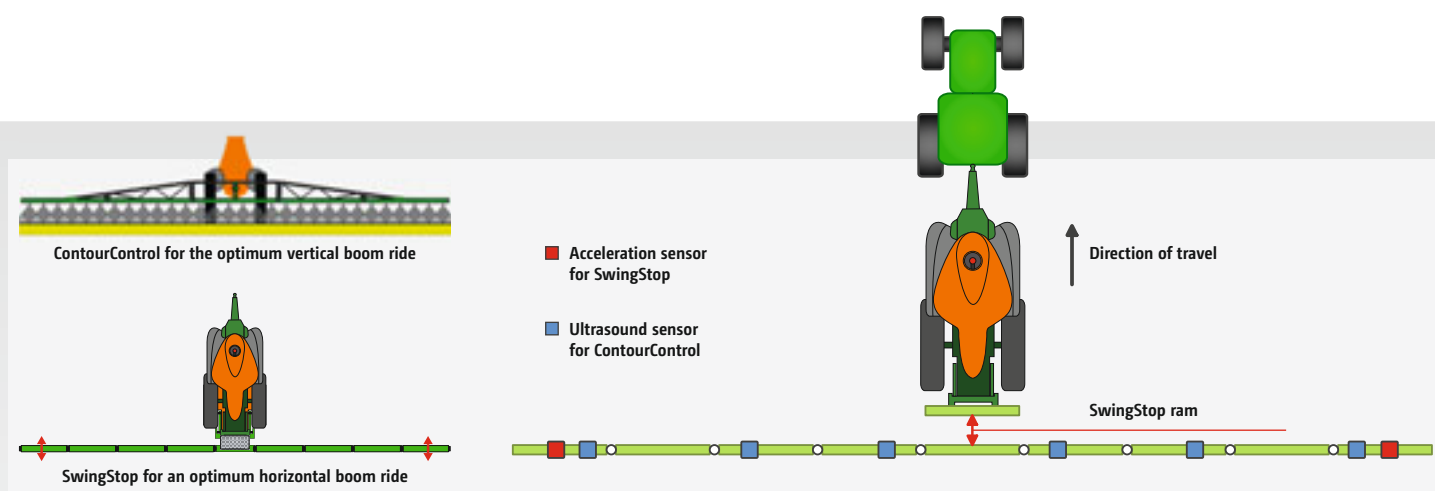

SwingStop optimises, especially on wider booms, the horizontal position. To reduce the amount of horizontal swing movement, the speed of acceleration that occurs in the boom ends is measured with the aid of acceleration sensors. The two actively operating hydraulic rams in the boom suspension work constantly to balance these swing movements and thus ensure a very smooth horizontal boom ride.

# UX 11200 trailed sprayer

A new dimension in plant protection technology

|                      |              |
|----------------------|--------------|
| <b>Tank capacity</b> | 11200 l      |
| <b>Working width</b> | 24 m to 40 m |



The combination of sprung drawbar, hydro-pneumatic suspension and axle steering come together to give an especially smooth, stress-free boom guidance and optimum driver comfort.

For all UF, UG and UX: The individual nozzle lighting targets the light to the spray fan when working during twilight and at night.

With the UX 11200, AMAZONE offers a 12000 l tandem axle sprayer for where there are extreme demands in output.

The Super-L boom is available in working widths from 24 m up to 40 m. The high-performance pumps provide a fill speed of up to 900 l/min.



UX 11200 trailed sprayer

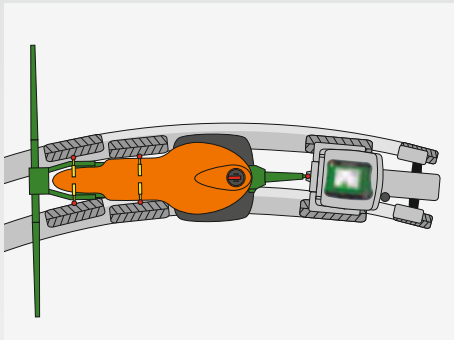

The UX 11200 can be equipped with the electronically-controlled DoubleTrail axle steering system. The track of the sprayer neatly follows the tractor avoiding any further track damage.



After the spraying operation is finished, with the aid of the spray lance on the wash down kit, any sprayer from AMAZONE can be thoroughly cleaned externally in the field.



The reversing camera, available for many AMAZONE machines, serves as a means of helping with safety when manoeuvring. However, it can also be used to check up on the function of the inner 8 nozzles behind the sprayer and, because of the night sight and heated lens technology, this is possible at any time.



# UG trailed sprayer

Proven technology for the most demanding use!

---

|                      |                  |
|----------------------|------------------|
| <b>UG Special</b>    | with single pump |
| <b>UG Super</b>      | with dual pump   |
| <b>Tank capacity</b> | 2200 l/3000 l    |
| <b>Working width</b> | 15 m to 28 m     |

---



UG 3000 Super trailed sprayer

The broad steel frame, compact tank and the robust boom technology with its profiled structure ensure optimised weight and strength.

The UG is therefore both extremely robust and light. All hoses are protected within the profile of the frame.



The clear control panel at the front left offers easy access for the fast, comfortable and error-free operation of all switches.



UG 3000 Super trailed sprayer



A tracking, universal, straight or hitch drawbar with hydraulic steering prevents wheel track damage. A braking system is available on request.



The laterally folding Super-L1 boom is available in working widths of 21 to 28 m.



The pressure re-circulation system (DUS) for all AMAZONE sprayers ensures that the concentration of spray chemical at the nozzle is always constant. When cleaning, the system is flushed with clear fresh water right up to the nozzle.

# Pantera, Pantera-H and Pantera-W self-propelled sprayers

Powerfully intelligent



Pantera 4502 self-propelled sprayer with a ground clearance of 1.2 m



Chassis Pantera-H

The special tandem chassis of the Pantera not only ensures the perfect adaptation to ground undulations, but also a high stability – of course, especially in sloping terrain. Thanks to the level-regulated, hydro-pneumatic suspension system the Pantera operator also enjoys the maximum level of comfort.

Latest technology and management systems are combined into this self-propelled crop protection sprayer. Equipped with “SpeedSpraying” up to 20 km/h, the Pantera operates quickly in the field. With up to 50 km/h maximum travelling speed, it is fast on the road. For crop protection treatments in high maize crops or in sunflowers, AMAZONE now offers the Pantera 4502-H with a hydraulically height adjustable chassis. Also, for when operating in very steep terrain, the self-propelled crop protection sprayer can be offered in the format Pantera<sup>†</sup> which has improved climbing ability.

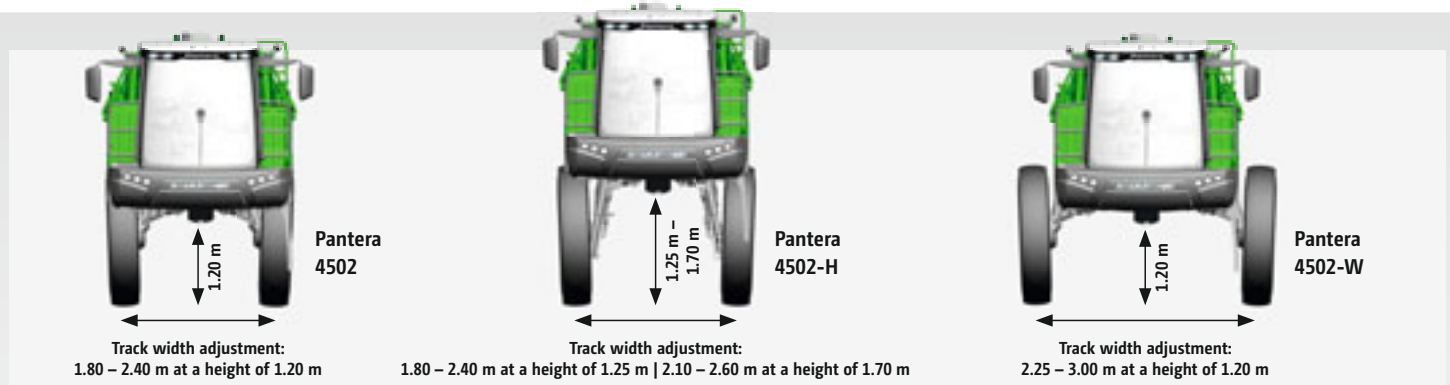

The fully automatic track width adjustment from 1.8 m to 2.4 m (with wide tyres also 2.6 m), fitted as standard, enables you to react quickly to the various demands of different crops. The Pantera 4502-W is equipped with a track width adjustment of 2.25 to 3 m. In “Controlled Traffic Farming” systems this special option makes the ideal alternative.



**Tank capacity** 4500 l

**Working width** 21 m to 40 m



Pantera 4502 self-propelled sprayer is compact in design and comes with four wheel drive

The 218 hp AMAZONE crop protection sprayer with a length of 8.4 m, a height of 3.8 m and a width of 2.55 m appears really compact. The comfort cab up front makes work easier and more convenient for the driver. Behind the cab, the 4500 l tank and the Super-L boom, with working widths of up to 40 m, are fitted enabling hourly work rates of more than 20 ha in good field conditions.

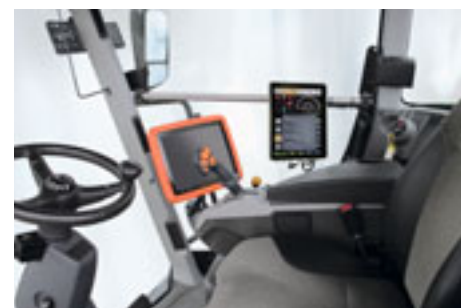

The Pantera driver's cab – with high class levels of equipment, best all-round visibility and high operational comfort.



The SunflowerKit for the Pantera-H self-propelled sprayer serves, when spraying or fertilising in tall crops, to prevent both damage to the crop as well as the underside of the machine. It ensures optimum safeguarding of the plants and, at the same time, protects the running gear units of the Pantera-H self propelled sprayer.

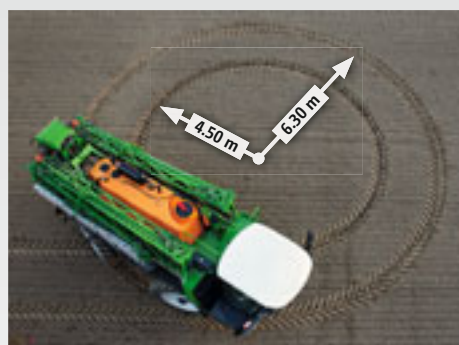

In spite of its size, the Pantera has a minimal turning circle of just 4.5 m when in all-wheel steer. This is helped by a short wheelbase and sharp steering angle.



Via the AmaPilot multi-function joystick and the AMADRIVE operator terminal, the Pantera offers a comfortable and simple operation.



As from the new model year, the Pantera will meet emission standard 4. With regard to the topic of post exhaust emissions treatment, AMAZONE relies on the exhaust gas recirculation with a diesel oxidation catalyst and diesel particulate filter – all of which help in saving the environment.

# AmaSwitch and AmaSelect individual nozzle switching

50 cm GPS part-width sections – tomorrow’s precision

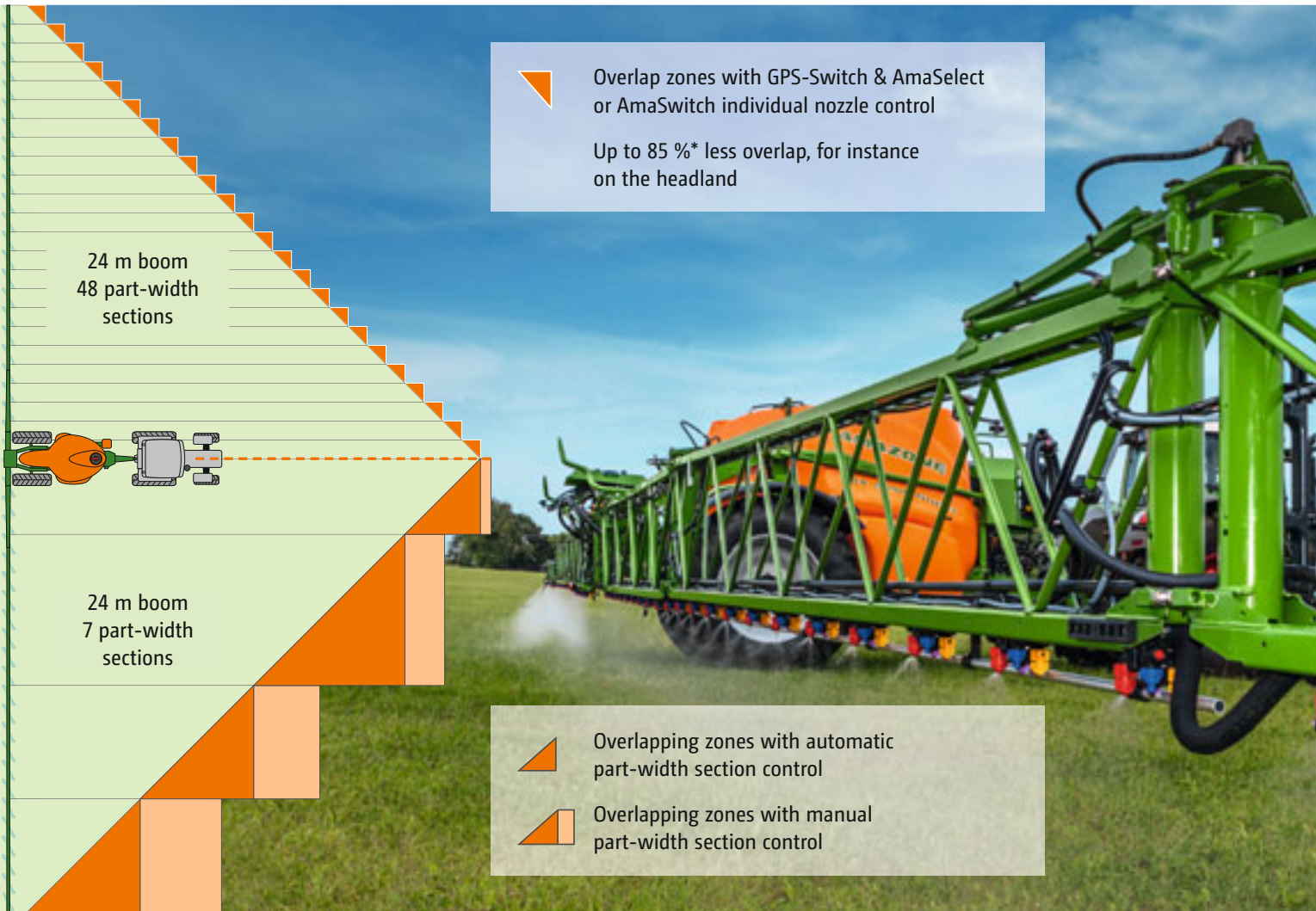

Automatic headland and part-width section control

**GPS-Switch**

**5%\***

Saving in crop protection chemical usage



Electric individual nozzle control

**AmaSwitch or AmaSelect**

**5%\***

Additional saving in crop protection chemical usage

\*The amount depends on the number of existing part-width sections, the field size and the boom width.





AmaSwitch individual nozzle switching

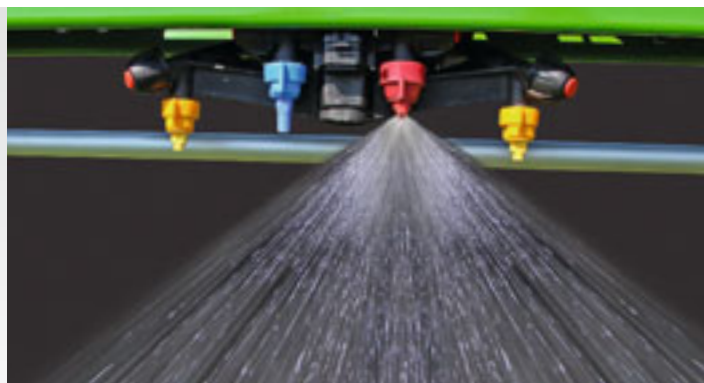

AmaSelect electric individual nozzle control with 4-fold nozzle body and 50 cm or 25 m nozzle spacing

## The cost effective alternative: AmaSwitch

- ✔ Electric individual nozzle switching
- ✔ Allows 50 cm part width sections to be switched via GPS
- ✔ Manual rotation of the 3-fold nozzle body
- ✔ Opening and closing of the nozzle via an electric valve
- ✔ As standard with DUS pro high pressure recirculation

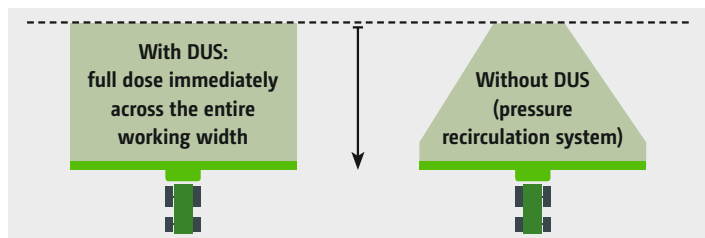

**DUS pressure recirculation system**  
Constant circulation of the spray agent even when the part-width sections have been shut off

## Optimum functionality for crop protection professionals: AmaSelect

- ✔ Electric individual nozzle switching via the 4-fold nozzle body
- ✔ Automatic adding or switching over of nozzles, that means nozzle change without having to leave the tractor cab
- ✔ 50 cm part-width sections are controlled automatically via GPS-Switch
- ✔ As an option with extension kit for 25 cm nozzle spacing
- ✔ Flexible configuration of working widths and part-width sections
- ✔ With integrated LED individual nozzle lighting
- ✔ As standard with DUS pro high pressure recirculation. For a maintained spray agent concentration and zero deposits in the spray pipes
- ✔ Minimal residual volumes and an even pressure conditions thanks to conical spray pipe

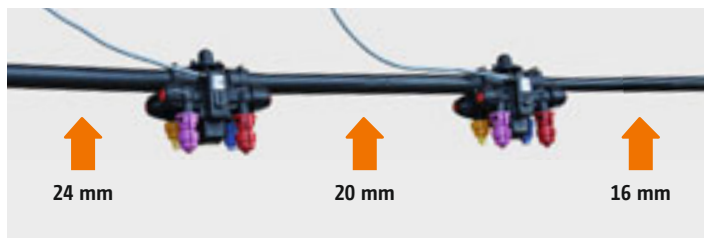

**Conical spray lines**  
The individual boom sections have differing pipe diameters

| System overview                          | Standard boom                                      | AmaSwitch  | AmaSelect                            |
|--|--|--|--------------------------------------|
| <b>The advantages</b>                    | UF mounted<br>UX trailed<br>Pantera self-propelled | UF mounted<br>UX trailed<br>Pantera self-propelled | UX trailed<br>Pantera self-propelled |
| Part-width sections                      | up to 13   | up to 80   | up to 80                             |
| 50 cm boom sections                      |  |  |                                      |
| Manual nozzle control                    |  |  |                                      |
| Automatic nozzle switch over and add-ins |  |  |                                      |
| Choice of nozzle from the cab            |  |  |                                      |
| Combinable nozzle selection              |  |  |                                      |
| High-pressure recirculation (DUS pro)    |  |  |                                      |
| 25 cm nozzle spacing                     |  |  |                                      |
| Freely-programmable section layout       |  |  |                                      |
| No air required                          |  |  |                                      |
| LED individual nozzle lighting           |  |  |                                      |

= included
  = optional
  = not possible



# Groundcare technology from AMAZONE









# Groundkeeper multi-functional mower/collector

Mowing, scarifying, collecting

|                 |                  |
|-----------------|------------------|
| Working width   | 1.35 m to 2.1 m  |
| Hopper capacity | 1200 l to 3500 l |



Groundkeeper multi-functional mower/collector



For the Groundkeeper and Profihopper ranges there is the SmartCut exact cut rotor that offers outstanding collection qualities. The outstanding feature of the SmartCut rotor is the special v-formation blade arrangement which leads to both a reduced fuel consumption and noise level.

The models for tractor mounting can be used throughout the year. In the spring, for scarifying lawns and golf courses, in the spring and summer for mowing sports pitches, parks, campsites, flower meadows and ecological sensitive meadows and, in the autumn, for collecting leaves.



Groundkeeper with drawbar; for use with smaller municipal tractors



The cutting height is individually adapted to the operation in question. The robust flail mower unit achieves optimum cutting quality and collection levels – even in wet or damp conditions.



Because of the strong suction effect produced by the rotor, the Groundkeeper can also be used for collecting mowed grass, leaves, twigs, acorns, chestnuts etc.



Scarifying and mowing horse paddocks while also picking up the cuttings and horse droppings prevents unwanted rank grass patches and the proliferation of parasites.



# Profihopper

The self-propelled machine for green area management

**Working width** 1.25 m

**Hopper capacity** 730 l



Profihopper multi-functional self-propelled mower collector

The Profihopper has a precision-cut rotor which is attached as a front-mounted mowing and scarifying unit. Its unique collection and compaction system makes the Profihopper particularly suitable for dust-free collection of grass and scarified material in a single operation in nearly all mowing conditions.



Once collected, the cuttings are immediately transported into an auger conveyor system, compacted and collected in the hopper. The compaction of the cuttings increases the actual capacity of the hopper from 730 l to a usable capacity of up to 1000 l.



Profihopper PH 4WDi with intelligent all-wheel drive and 0-radius turn



The Profihopper 4WDi, with intelligent all-wheel drive, is equipped with the new PowerCompactor high output mowing system and a steering wheel for a perfect 0-radius turn.



The Profihopper iDrive, which is ideal for normal operating conditions, is also fitted as standard with the new PowerCompactor high output mowing system, intuitive steering via a steering wheel and a perfect 0-radius turn. The front wheel drive comes from two hydraulic motors.



Profihopper zDrive: The lever steering makes possible a real Zero-Turn about the rear castor wheels and increases the flexibility when working within confined spaces. Clean, precise mowing is possible because the material to be cut is not driven over first.



# Landscape maintenance combination GNK and GBK

For gardening and landscaping

Working width 1.1 m to 2.5 m



GNK grass seeding combination with scarifying tines



The seed wheels, arranged continuously along the entire width of the bottom part of the grass seed drill, broadcast the seed widely and evenly. The desired depth is achieved by setting the seed chute.

When it comes to renovation or rejuvenation of all green spaces and artificial hard courts, AMAZONE landscape combinations complete the task superbly. Whether for light or heavy soil tillage, areas with little or abundant vegetation, for sowing, over-sowing or levelling out unevenness, the modular system ensures it is the ideal machine for any application.



GNK grass seeding combination



GBK grass reseeding combination of reciprocating harrow, grass seed drill and either screen or smooth roller. The reciprocating power harrow with its low tractor power and lift requirement is ideal for the precise sowing of grass and for reseeding green spaces.



GBK grass reseeding combination of rotary harrow, grass seed drill and screen roller. In just one pass the ground is broken up and thoroughly mixed with any organic matter being well incorporated. The rotary harrow works without blockage and, at the same time, crumbles the coarser, upper soil layer.



The screen or smooth roller presses in the seed. It also controls the depth of the soil tillage machinery and carries the grass seed drill.



# E+S, EK-S and ZA-XS spreaders

## Versatile use

**Hopper capacity** 150 l to 1110 l

**Working width** 0.8 m to 8 m



With minimal expense, the E+S winter application spreader can also be equipped for spreading granular fertiliser. It produces an excellent lateral and longitudinal spread pattern as well as achieving high work rates.

E+S single disc centrifugal broadcaster

With the E+S, EK-S and ZA-XS models, AMAZONE offers three high-class spreaders for the application of a vast array of differing spreading materials. Whether it is the E+S or EK-S for winter salt application, or the ZA-XS for road construction, it means that, for any application and any requirement, the right spreader is available. All these spreaders are characterised by their very robust and reliable design and guarantee a high degree of precision.



EasySet in cab operator terminal: for the electric operation of the shutter slide and spread width reduction



The E+S Hydro 751 winter salt spreader is equipped with a 750 litre hopper, hydraulic spreading disc drive and a forward speed related spread rate regulation



The E+S mounted spreader is ideally suited for the professional application of winter road salt. With its working widths of up to 8 m and hopper sizes from 300 to 1110 l, this high-performance single disc spreader impresses with its very precise spread pattern.



The EK-S mounted spreader is ideally suited for the reliable operation in winter salt application. With its working widths of up to 8 m and hopper sizes of 150 to 370 l, it is perfect for medium application rates.



The ZA-XS H mounted spreader has been designed especially for road construction. Thanks to its hydraulic drive, this twin disc spreader is ideally suited for road rollers which simultaneously apply grit to the road.



# Model overview







## Soil tillage

### Cayros mounted reversible ploughs



|                 |                             |  |   |
|-----------------|-----------------------------|--|---|
| ▶ Cayros M      | Power requirement to 120 hp | Working width per body 32, 36, 40, 44, 48 cm                                   | Mechanical adjustment<br>Hydraulic adjustment |
| ▶ Cayros XM     | Power requirement to 140 hp | Working width per body 36, 40, 44, 48 cm                                       | Mechanical adjustment<br>Hydraulic adjustment |
| ▶ Cayros XMS    | Power requirement to 200 hp | Working width per body 36, 40, 44, 48 cm                                       | Mechanical adjustment<br>Hydraulic adjustment |
| ▶ Cayros XS     | Power requirement to 260 hp | Working width per body 36, 40, 44, 48 cm                                       | Mechanical adjustment<br>Hydraulic adjustment |
| ▶ Cayros XS pro | Power requirement to 380 hp | Working width per body 36, 40, 44, 48 cm<br>Working width per body 32 to 55 cm | Mechanical adjustment<br>Hydraulic adjustment |

### Cayron mounted reversible ploughs



|                   |                             |                                      |                       |
|-------------------|-----------------------------|--------------------------------------|-----------------------|
| ▶ Cayron 200 5    | Power requirement to 240 hp | Working width per body 40, 45, 50 cm | Mechanical adjustment |
| ▶ Cayron 200 5+1  | Power requirement to 240 hp | Working width per body 40, 45, 50 cm | Mechanical adjustment |
| ▶ Cayron 200 V5   | Power requirement to 290 hp | Working width per body 30 to 55 cm   | Hydraulic adjustment  |
| ▶ Cayron 200 V5+1 | Power requirement to 290 hp | Working width per body 30 to 55 cm   | Hydraulic adjustment  |

### KE rotary harrows



|                   |                             |                      |       |
|-------------------|-----------------------------|----------------------|-------|
| ▶ KE 2500 Special | Power requirement to 140 hp | Working width 2.50 m | Rigid |
| ▶ KE 3000 Special | Power requirement to 140 hp | Working width 3.00 m | Rigid |
| ▶ KE 3000 Super   | Power requirement to 180 hp | Working width 3.00 m | Rigid |
| ▶ KE 3500 Super   | Power requirement to 180 hp | Working width 3.50 m | Rigid |
| ▶ KE 4000 Super   | Power requirement to 180 hp | Working width 4.00 m | Rigid |

### KG rotary cultivator - KX



|                   |                             |                      |       |
|-------------------|-----------------------------|----------------------|-------|
| ▶ KG 3000 Special | Power requirement to 220 hp | Working width 3.00 m | Rigid |
| ▶ KG 3500 Special | Power requirement to 220 hp | Working width 3.50 m | Rigid |
| ▶ KG 4000 Special | Power requirement to 220 hp | Working width 4.00 m | Rigid |

|                 |                             |                      |       |
|-----------------|-----------------------------|----------------------|-------|
| ▶ KG 3000 Super | Power requirement to 300 hp | Working width 3.00 m | Rigid |
| ▶ KG 3500 Super | Power requirement to 300 hp | Working width 3.50 m | Rigid |
| ▶ KG 4000 Super | Power requirement to 300 hp | Working width 4.00 m | Rigid |

|             |                             |                      |                   |
|-------------|-----------------------------|----------------------|-------------------|
| ▶ KG 4001-2 | Power requirement to 300 hp | Working width 4.00 m | Hydraulic folding |
| ▶ KG 5001-2 | Power requirement to 300 hp | Working width 5.00 m | Hydraulic folding |
| ▶ KG 6001-2 | Power requirement to 300 hp | Working width 6.00 m | Hydraulic folding |



|           |                             |                      |       |
|-----------|-----------------------------|----------------------|-------|
| ▶ KX 3000 | Power requirement to 190 hp | Working width 3.00 m | Rigid |
|-----------|-----------------------------|----------------------|-------|

### Catros compact disc harrows



|   |                               |                      |       |
|---|-------------------------------|----------------------|-------|
| ▶ Catros/Catros <sup>+</sup> 2503 Special | Power requirement from 75 hp  | Working width 2.50 m | Rigid |
| ▶ Catros/Catros <sup>+</sup> 3003 Special | Power requirement from 90 hp  | Working width 3.00 m | Rigid |
| ▶ Catros/Catros <sup>+</sup> 3503 Special | Power requirement from 105 hp | Working width 3.50 m | Rigid |
| ▶ Catros/Catros <sup>+</sup> 4003 Special | Power requirement from 125 hp | Working width 4.00 m | Rigid |



|                                   |                               |                      |       |
|-----------------------------------|-------------------------------|----------------------|-------|
| ▶ Catros/Catros <sup>+</sup> 3001 | Power requirement from 90 hp  | Working width 3.00 m | Rigid |
| ▶ Catros/Catros <sup>+</sup> 3501 | Power requirement from 105 hp | Working width 3.50 m | Rigid |
| ▶ Catros/Catros <sup>+</sup> 4001 | Power requirement from 125 hp | Working width 4.00 m | Rigid |



## Soil tillage

### Catros compact disc harrows



|   |                               |                       |                           |
|---|-------------------------------|-----------------------|---------------------------|
| ▶ Catros <sup>XL</sup> 3003                                       | Power requirement from 120 hp | Working width 3.00 m  | Rigid                     |
| ▶ Catros <sup>XL</sup> 3503                                       | Power requirement from 140 hp | Working width 3.50 m  | Rigid                     |
| ▶ Catros <sup>XL</sup> 4003                                       | Power requirement from 160 hp | Working width 4.00 m  | Rigid                     |
| ▶ Catros/Catros <sup>+</sup> 4002-2                               | Power requirement from 125 hp | Working width 4.00 m  | Hydraulic folding         |
| ▶ Catros/Catros <sup>+</sup> 5002-2                               | Power requirement from 150 hp | Working width 5.00 m  | Hydraulic folding         |
| ▶ Catros/Catros <sup>+</sup> 6002-2                               | Power requirement from 180 hp | Working width 6.00 m  | Hydraulic folding         |
| ▶ Catros/Catros <sup>+</sup> 4002-2TS                             | Power requirement from 125 hp | Working width 4.00 m  | Hydraulic folding/trailed |
| ▶ Catros/Catros <sup>+</sup> 5002-2TS                             | Power requirement from 150 hp | Working width 5.00 m  | Hydraulic folding/trailed |
| ▶ Catros/Catros <sup>+</sup> 6002-2TS                             | Power requirement from 180 hp | Working width 6.00 m  | Hydraulic folding/trailed |
| ▶ Catros <sup>+</sup> 7003-2TX                                    | Power requirement from 210 hp | Working width 7.00 m  | Hydraulic folding/trailed |
| ▶ Catros <sup>+</sup> 8003-2TX                                    | Power requirement from 240 hp | Working width 8.00 m  | Hydraulic folding/trailed |
| ▶ Catros <sup>+</sup> 9003-2TX                                    | Power requirement from 270 hp | Working width 9.00 m  | Hydraulic folding/trailed |
| ▶ Catros <sup>+</sup> 12003-2TS                                   | Power requirement from 360 hp | Working width 12.00 m | Hydraulic folding/trailed |
| ▶ Catros/Catros <sup>+</sup> with KR 9002 trailed carrier system  |                               | Working width 9.00 m  | Hydraulic folding/trailed |
| ▶ Catros/Catros <sup>+</sup> with KR 12002 trailed carrier system |                               | Working width 12.00 m | Hydraulic folding/trailed |

### Certos heavy compact disc harrows



|                   |                               |                      |                 |
|-------------------|-------------------------------|----------------------|-----------------|
| ▶ Certos 4001-2TX | Power requirement from 160 hp | Working width 4.00 m | Folding/trailed |
| ▶ Certos 5001-2TX | Power requirement from 200 hp | Working width 4.90 m | Folding/trailed |
| ▶ Certos 6001-2TX | Power requirement from 250 hp | Working width 6.00 m | Folding/trailed |
| ▶ Certos 7001-2TX | Power requirement from 350 hp | Working width 7.00 m | Folding/trailed |

### Cenius mulch cultivators



|                                 |                               |                      |                   |
|---------------------------------|-------------------------------|----------------------|-------------------|
| ▶ Cenius 3003 Special/Super     | Power requirement from 125 hp | Working width 3.00 m | Rigid             |
| ▶ Cenius 3503 Special/Super     | Power requirement from 140 hp | Working width 3.50 m | Rigid             |
| ▶ Cenius 4003 Special/Super     | Power requirement from 160 hp | Working width 4.00 m | Rigid             |
| ▶ Cenius 4003-2 Special/Super   | Power requirement from 160 hp | Working width 4.00 m | Hydraulic folding |
| ▶ Cenius 4003-2TX Special/Super | Power requirement from 200 hp | Working width 4.00 m | Hydraulic folding |
| ▶ Cenius 5003-2TX Special/Super | Power requirement from 250 hp | Working width 5.00 m | Hydraulic folding |
| ▶ Cenius 6003-2TX Special/Super | Power requirement from 300 hp | Working width 6.00 m | Hydraulic folding |
| ▶ Cenius 7003-2TX Special/Super | Power requirement from 350 hp | Working width 7.00 m | Hydraulic folding |
| ▶ Cenius 8003-2TX Special/Super | Power requirement from 400 hp | Working width 8.00 m | Hydraulic folding |

### Ceus disc harrow cultivator combination



|                 |                               |                      |                   |
|-----------------|-------------------------------|----------------------|-------------------|
| ▶ Ceus 4000-2TX | Power requirement from 200 hp | Working width 4.00 m | Hydraulic folding |
| ▶ Ceus 5000-2TX | Power requirement from 250 hp | Working width 5.00 m | Hydraulic folding |
| ▶ Ceus 6000-2TX | Power requirement from 300 hp | Working width 6.00 m | Hydraulic folding |
| ▶ Ceus 7000-2TX | Power requirement from 350 hp | Working width 7.00 m | Hydraulic folding |

### AW land rollers



|            |                               |                       |                   |
|------------|-------------------------------|-----------------------|-------------------|
| ▶ AW 6600  | Power requirement from 80 hp  | Working width 6.60 m  | Hydraulic folding |
| ▶ AW 7800  | Power requirement from 110 hp | Working width 7.80 m  | Hydraulic folding |
| ▶ AW 9400  | Power requirement from 130 hp | Working width 9.40 m  | Hydraulic folding |
| ▶ AW 12200 | Power requirement from 150 hp | Working width 12.20 m | Hydraulic folding |
| ▶ AW 15400 | Power requirement from 180 hp | Working width 15.40 m | Hydraulic folding |

## Sowing technology

### D9 mounted gravity seed drills



|                   |                       |                                     |                                |
|-------------------|-----------------------|-------------------------------------|--------------------------------|
| ▶ D9 2500 Special | Working width 2.50 m  | Seed hopper capacity 360 l          | Rigid                          |
| ▶ D9 3000 Special | Working width 3.00 m  | Seed hopper capacity 450 to 850 l   | Rigid                          |
| ▶ D9 3000 Super   | Working width 3.00 m  | Seed hopper capacity 600 to 1000 l  | Rigid                          |
| ▶ D9 3500 Super   | Working width 3.50 m  | Seed hopper capacity 720 to 1200 l  | Rigid                          |
| ▶ D9 4000 Super   | Working width 4.00 m  | Seed hopper capacity 830 to 1380 l  | Rigid                          |
| ▶ D9 60 Super     | Working width 6.00 m  | Seed hopper capacity 1200 to 2000 l | Rigid                          |
| ▶ D9 9000-KR      | Working width 9.00 m  | Seed hopper capacity 1800 to 3000 l | With KR trailed carrier system |
| ▶ D9 12000-KR     | Working width 12.00 m | Seed hopper capacity 2490 to 4140 l | With KR trailed carrier system |

### AD pack top gravity seed drills



|                   |                      |                                    |       |
|-------------------|----------------------|------------------------------------|-------|
| ▶ AD 2500 Special | Working width 2.50 m | Seed hopper capacity 360 l         | Rigid |
| ▶ AD 3000 Special | Working width 3.00 m | Seed hopper capacity 450 to 850 l  | Rigid |
| ▶ AD 3000 Super   | Working width 3.00 m | Seed hopper capacity 600 to 1000 l | Rigid |
| ▶ AD 3500 Super   | Working width 3.50 m | Seed hopper capacity 720 to 1200 l | Rigid |
| ▶ AD 4000 Super   | Working width 4.00 m | Seed hopper capacity 830 to 1380 l | Rigid |

### Cataya conventional seed drill combinations



|                       |                      |                                    |       |
|-----------------------|----------------------|------------------------------------|-------|
| ▶ Cataya 3000 Special | Working width 3.00 m | Seed hopper capacity 650 to 850 l  | Rigid |
| ▶ Cataya 3000 Super   | Working width 3.00 m | Seed hopper capacity 830 to 1270 l | Rigid |

### AD-P pneumatic seed drills



|                     |                      |                                     |       |
|---------------------|----------------------|-------------------------------------|-------|
| ▶ AD-P 3001 Special | Working width 3.00 m | Seed hopper capacity 850 to 1500 l  | Rigid |
| ▶ AD-P 3500 Special | Working width 3.50 m | Seed hopper capacity 850 to 1500 l  | Rigid |
| ▶ AD-P 4000 Special | Working width 4.00 m | Seed hopper capacity 850 to 1500 l  | Rigid |
| ▶ AD-P 3000 Super   | Working width 3.00 m | Seed hopper capacity 1500 to 2000 l | Rigid |
| ▶ AD-P 4000 Super   | Working width 4.00 m | Seed hopper capacity 1500 to 2000 l | Rigid |

### Centaya pneumatic seed drills



|                 |                      |                                     |       |
|-----------------|----------------------|-------------------------------------|-------|
| ▶ Centaya Super | Working width 3.00 m | Seed hopper capacity 1600 to 2000 l | Rigid |
|-----------------|----------------------|-------------------------------------|-------|

### Avant pneumatic seed drills



|                |                      |                                     |                   |
|----------------|----------------------|-------------------------------------|-------------------|
| ▶ Avant 4001   | Working width 4.00 m | Seed hopper capacity 1500 to 2000 l | Rigid             |
| ▶ Avant 4001-2 | Working width 4.00 m | Seed hopper capacity 1500 to 2000 l | Hydraulic folding |
| ▶ Avant 5001-2 | Working width 5.00 m | Seed hopper capacity 1500 to 2000 l | Hydraulic folding |
| ▶ Avant 6001-2 | Working width 6.00 m | Seed hopper capacity 1500 to 2000 l | Hydraulic folding |



## Sowing technology

### Cirrus pneumatic seed drills



- ▶ Cirrus 3003 Compact
- ▶ Cirrus 3503 Compact

Working width 3.00 m  
Working width 3.50 m

Seed hopper capacity 3000 l  
Seed hopper capacity 3000 l

Rigid  
Rigid



- ▶ Cirrus 4003
- ▶ Cirrus 4003-C
- ▶ Cirrus 4003-2
- ▶ Cirrus 4003-2C
- ▶ Cirrus 6003-2
- ▶ Cirrus 6003-2C

Working width 4.00 m  
Working width 4.00 m  
Working width 4.00 m  
Working width 4.00 m  
Working width 6.00 m  
Working width 6.00 m

Seed hopper capacity 3600 l  
Seed hopper capacity 4000 l  
Seed hopper capacity 3600 l  
Seed hopper capacity 4000 l  
Seed hopper capacity 3600 l  
Seed hopper capacity 4000 l

Rigid  
Rigid  
Hydraulic folding  
Hydraulic folding  
Hydraulic folding  
Hydraulic folding

### Citan pneumatic seed drills



- ▶ Citan 8000
- ▶ Citan 9000
- ▶ Citan 12001-C
- ▶ Citan 15001-C

Working width 8.00 m  
Working width 9.00 m  
Working width 12.00 m  
Working width 15.00 m

Seed hopper capacity 4600 l  
Seed hopper capacity 4600 l  
Seed hopper capacity 8000 l  
Seed hopper capacity 8000 l

Hydraulic folding  
Hydraulic folding  
Hydraulic folding  
Hydraulic folding

### Cayena pneumatic seed drills



- ▶ Cayena 6001
- ▶ Cayena 6001-C

Working width 6.00 m  
Working width 6.00 m

Seed hopper capacity 3600 l  
Seed hopper capacity 4000 l

Hydraulic folding  
Hydraulic folding

### Condor pneumatic seed drills



- ▶ Condor 12001-C
- ▶ Condor 15001-C

Working width 12.00 m  
Working width 15.00 m

Seed hopper capacity 8000 l  
Seed hopper capacity 8000 l

Hydraulic folding  
Hydraulic folding

### Primera DMC pneumatic seed drills



- ▶ Primera DMC 3000/3000-C
- ▶ Primera DMC 4500/4500-C
- ▶ Primera DMC 6000-2/6000-2C
- ▶ Primera DMC 9000-2/9000-2C
- ▶ Primera DMC 9000-2C Super
- ▶ Primera DMC 12000-2C

Working width 3.00 m  
Working width 4.50 m  
Working width 6.00 m  
Working width 9.00 m  
Working width 9.00 m  
Working width 12.00 m

Seed hopper capacity 4200 l  
Seed hopper capacity 4200 l  
Seed hopper capacity 4200 l  
Seed hopper capacity 4200 l  
Seed hopper capacity 6000 l  
Seed hopper capacity 6000 l

Rigid  
Rigid  
Hydraulic folding  
Hydraulic folding  
Hydraulic folding  
Hydraulic folding



- ▶ Primera DMC 9001-2C
- ▶ Primera DMC 12001-2C

Working width 9.00 m  
Working width 12.00 m

Seed hopper capacity 13000 l  
Seed hopper capacity 13000 l

Hydraulic folding  
Hydraulic folding

### ED pneumatic precision air seeders



- ▶ ED 3000-C Special/Super
- ▶ ED 4500-C Special/Super
- ▶ ED 6000-C Special/Super
- ▶ ED 4500-2C Special/Super
- ▶ ED 6000-2C Special/Super
- ▶ ED 6000-2FC Special/Super

Working width 3.00 m  
Working width 4.50 m  
Working width 6.00 m  
Working width 4.50 m  
Working width 6.00 m  
Working width 6.00 m

Number of sowing units 4 to 6  
Number of sowing units 6 or 8  
Number of sowing units 8 to 12  
Number of sowing units 6 or 7  
Number of sowing units 8 or 9  
Number of sowing units 8 or 12

Rigid  
Rigid  
Rigid  
Hydraulic folding  
Hydraulic folding  
Hydraulic folding



- ▶ ED 9000-KR
- ▶ ED 12000-KR

Working width 9.00 m  
Working width 12.00 m

With KR trailed carrier system  
With KR trailed carrier system

Hydraulic folding  
Hydraulic folding

### EDX pneumatic precision air seeders



- ▶ EDX 6000-TC
- ▶ EDX 9000-TC

Working width 6.00 m  
Working width 9.00 m

Number of sowing units 8 to 16  
Number of sowing units 12 to 20

Hydraulic folding  
Hydraulic folding

## Fertilisation technology

### ZA-X Perfect fertiliser spreaders



|                     |                                     |                          |
|---------------------|-------------------------------------|--------------------------|
| ▶ ZA-XW Perfect 502 | Hopper capacity 500 to max. 700 l   | Working width 10 to 18 m |
| ▶ ZA-X Perfect 602  | Hopper capacity 600 to max. 850 l   | Working width 10 to 18 m |
| ▶ ZA-X Perfect 902  | Hopper capacity 900 to max. 1700 l  | Working width 10 to 18 m |
| ▶ ZA-X Perfect 1402 | Hopper capacity 1400 to max. 1750 l | Working width 10 to 18 m |

### ZA-M fertiliser spreaders



|                            |                                     |                          |
|----------------------------|-------------------------------------|--------------------------|
| ▶ ZA-M 1001 Special        | Hopper capacity 1000 to max. 1500 l | Working width 10 to 36 m |
| ▶ ZA-M 1201                | Hopper capacity 1200 to max. 2700 l | Working width 10 to 36 m |
| ▶ ZA-M 1501                | Hopper capacity 1500 to max. 3000 l | Working width 10 to 36 m |
| ▶ ZA-M 1001 Special Profis | Hopper capacity 1000 to max. 2000 l | Working width 10 to 36 m |

### ZA-V fertiliser spreaders



|             |                                     |                          |
|-------------|-------------------------------------|--------------------------|
| ▶ ZA-V 1400 | Hopper capacity 1400 to max. 2000 l | Working width 10 to 36 m |
| ▶ ZA-V 1700 | Hopper capacity 1700 to max. 2300 l | Working width 10 to 36 m |
| ▶ ZA-V 2000 | Hopper capacity 2000 to max. 2600 l | Working width 10 to 36 m |
| ▶ ZA-V 2200 | Hopper capacity 2200 to max. 3000 l | Working width 10 to 36 m |
| ▶ ZA-V 2600 | Hopper capacity 2600 l              | Working width 10 to 36 m |
| ▶ ZA-V 2700 | Hopper capacity 2700 to max. 3500 l | Working width 10 to 36 m |
| ▶ ZA-V 3200 | Hopper capacity 3200 to max. 4000 l | Working width 10 to 36 m |
| ▶ ZA-V 4200 | Hopper capacity 4200 l              | Working width 10 to 36 m |

### ZA-TS fertiliser spreaders



|              |                                     |                          |
|--------------|-------------------------------------|--------------------------|
| ▶ ZA-TS 1400 | Hopper capacity 1400 to max. 2000 l | Working width 15 to 54 m |
| ▶ ZA-TS 1700 | Hopper capacity 1700 to max. 2300 l | Working width 15 to 54 m |
| ▶ ZA-TS 2000 | Hopper capacity 2000 to max. 2600 l | Working width 15 to 54 m |
| ▶ ZA-TS 2200 | Hopper capacity 2200 to max. 3000 l | Working width 15 to 54 m |
| ▶ ZA-TS 2600 | Hopper capacity 2600 l              | Working width 15 to 54 m |
| ▶ ZA-TS 2700 | Hopper capacity 2700 to max. 3500 l | Working width 15 to 54 m |
| ▶ ZA-TS 3200 | Hopper capacity 3200 to max. 4000 l | Working width 15 to 54 m |
| ▶ ZA-TS 4200 | Hopper capacity 4200 l              | Working width 15 to 54 m |

### ZG-TS trailed bulk material and fertiliser spreaders



|              |                        |                          |
|--------------|------------------------|--------------------------|
| ▶ ZG-TS 5500 | Hopper capacity 5500 l | Working width 15 to 54 m |
| ▶ ZG-TS 8200 | Hopper capacity 8200 l | Working width 15 to 54 m |

### ZG-B trailed bulk material and fertiliser spreaders



|             |                        |                          |
|-------------|------------------------|--------------------------|
| ▶ ZG-B 5500 | Hopper capacity 5500 l | Working width 10 to 36 m |
| ▶ ZG-B 8200 | Hopper capacity 8200 l | Working width 10 to 36 m |



## Plant protection systems

### UF mounted sprayers



|           |                              |                       |                          |
|-----------|------------------------------|-----------------------|--------------------------|
| ▶ UF 901  | Nominal tank capacity 1050 l | Boom width 12 to 30 m | Hydraulic/manual folding |
| ▶ UF 1201 | Nominal tank capacity 1350 l | Boom width 12 to 30 m | Hydraulic/manual folding |
| ▶ UF 1501 | Nominal tank capacity 1720 l | Boom width 12 to 30 m | Hydraulic/manual folding |
| ▶ UF 1801 | Nominal tank capacity 1920 l | Boom width 12 to 30 m | Hydraulic/manual folding |
| ▶ UF 2002 | Nominal tank capacity 2000 l | Boom width 15 to 30 m | Hydraulic/manual folding |

### FT 1001 front tank



|           |                             |
|-----------|-----------------------------|
| ▶ FT 1001 | Usable tank capacity 1000 l |
|-----------|-----------------------------|

### Self-propelled sprayers



|                  |                              |                       |                                  |
|------------------|------------------------------|-----------------------|----------------------------------|
| ▶ Pantera 4502   | Nominal tank capacity 4800 l | Boom width 21 to 40 m | Track width adjustment           |
| ▶ Pantera 4502-H | Nominal tank capacity 4800 l | Boom width 21 to 40 m | Track width/height adjustment    |
| ▶ Pantera 4502-W | Nominal tank capacity 4800 l | Boom width 21 to 40 m | Over-wide track width adjustment |

### UG trailed sprayers



|                   |                              |                       |                   |
|-------------------|------------------------------|-----------------------|-------------------|
| ▶ UG 2200 Special | Nominal tank capacity 2400 l | Boom width 15 to 28 m | Hydraulic folding |
| ▶ UG 3000 Special | Nominal tank capacity 3200 l | Boom width 15 to 28 m | Hydraulic folding |
| ▶ UG 2200 Super   | Nominal tank capacity 2400 l | Boom width 15 to 28 m | Hydraulic folding |
| ▶ UG 3000 Super   | Nominal tank capacity 3200 l | Boom width 15 to 28 m | Hydraulic folding |

### UX trailed sprayers



|                   |                              |                       |                   |
|-------------------|------------------------------|-----------------------|-------------------|
| ▶ UX 3200 Special | Nominal tank capacity 3600 l | Boom width 15 to 30 m | Hydraulic folding |
| ▶ UX 4200 Special | Nominal tank capacity 4600 l | Boom width 15 to 30 m | Hydraulic folding |



|                 |                              |                       |                   |
|-----------------|------------------------------|-----------------------|-------------------|
| ▶ UX 3200 Super | Nominal tank capacity 3600 l | Boom width 18 to 36 m | Hydraulic folding |
| ▶ UX 4200 Super | Nominal tank capacity 4600 l | Boom width 18 to 40 m | Hydraulic folding |
| ▶ UX 5200 Super | Nominal tank capacity 5600 l | Boom width 18 to 40 m | Hydraulic folding |
| ▶ UX 6200 Super | Nominal tank capacity 6560 l | Boom width 18 to 40 m | Hydraulic folding |



|                 |                              |                       |                   |
|-----------------|------------------------------|-----------------------|-------------------|
| ▶ UX 4201 Super | Nominal tank capacity 4600 l | Boom width 27 to 40 m | Hydraulic folding |
| ▶ UX 5201 Super | Nominal tank capacity 5600 l | Boom width 27 to 40 m | Hydraulic folding |
| ▶ UX 6201 Super | Nominal tank capacity 6600 l | Boom width 27 to 40 m | Hydraulic folding |

|            |                               |                       |                   |
|------------|-------------------------------|-----------------------|-------------------|
| ▶ UX 11200 | Nominal tank capacity 12000 l | Boom width 24 to 40 m | Hydraulic folding |
|------------|-------------------------------|-----------------------|-------------------|

# Competent advice

Talk to your AMAZONE sales agent or give us a call.



Illustrations, content and technical data are not binding! Technical data may deviate according to the level of equipment.  
Machine illustrations can vary due to country-specific traffic legislation.



**AMAZONEN-WERKE H. DREYER GmbH & Co. KG**  
P. O. Box 51 · 49202 Hasbergen-Gaste/Germany  
Phone +49 (0)5405 501-0 · Fax +49 (0)5405 501-193